

YE-IT24
EUROPE
2023/2024

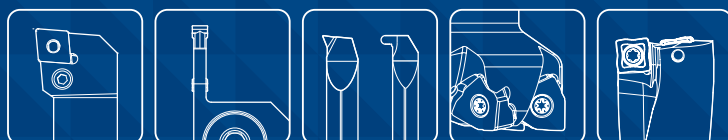

CUTTING TOOLS



INDEXABLE INSERTS

YG YG-1 CO., LTD.

If you Click an icon or page number, you can easily find information as below;

- 1 Go to the page
- 2 Go to the Index
- 3 Go to the Overview
- 4 Go to the section
- 5 Watch the video

Contents		Page
1	External Turning Holder Code	4
	Internal Turning Holder Code	6
	Insert ISO Code System	8
	Grade Naming System	10
	Turning Grades Map	11
	Turning Grades	12

Series	Size & Thickness	Page
CNMA	1204 1606 1906	62
CNMG	1204 1606 1906	
DNMA	1304 1306	65
DNMG	1304 1306	
KNVTX	1604	68

Series	Turning Holder	Page
CCGT	SCARL	p. 31
CCMT	SCORL	p. 31

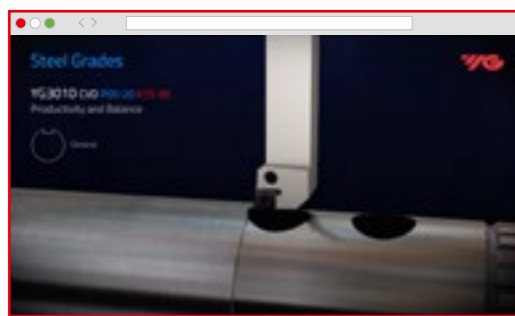

5



2

3

4

IGTURN
Turning Inserts - Negative
CNMA / CNMG (80° Rhombic)

Designation	RE	F _h (mm/min)	Ap (mm)
CNMA 1204H	04	0.15-0.50	0.5-5.0
CNMA 1204H	08	0.15-0.50	1.0-5.0
CNMA 120412	12	0.15-0.50	1.5-5.0
CNMA 120416	16	0.15-0.50	2.0-5.0
CNMA 160412	12	0.15-0.50	1.5-5.0
CNMA 160416	16	0.15-0.50	2.0-5.0
CNMA 190412	12	0.15-0.50	1.5-5.0
CNMA 190416	16	0.15-1.00	3.0-10.0
CNMG 1204H-UF	04	0.05-0.25	0.5-2.5
CNMG 1204H-UF	08	0.05-0.25	1.0-2.5
CNMG 120412-UF	12	0.05-0.25	1.5-2.5
CNMG 080308-UL	08	0.10-0.30	1.0-2.5
CNMG 080312-UL	12	0.10-0.30	1.5-2.5
CNMG 080408-UL	08	0.10-0.30	1.0-2.5
CNMG 080412-UL	12	0.10-0.30	1.5-2.5
CNMG 120404-UL	04	0.10-0.30	0.5-3.0
CNMG 120408-UL	08	0.10-0.30	1.0-3.0
CNMG 120412-UL	12	0.10-0.30	1.5-3.0
CNMG 120404-UM	04	0.15-0.30	0.5-3.0
CNMG 120408-UM	08	0.15-0.30	1.0-3.0
CNMG 120412-UM	12	0.15-0.30	1.5-3.0



INDEXABLE INSERTS



TURNING



PARTING GROOVING

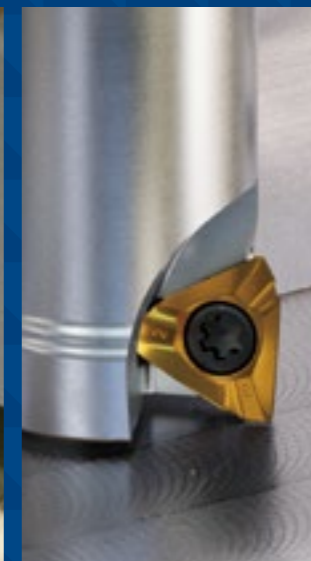

MILLING

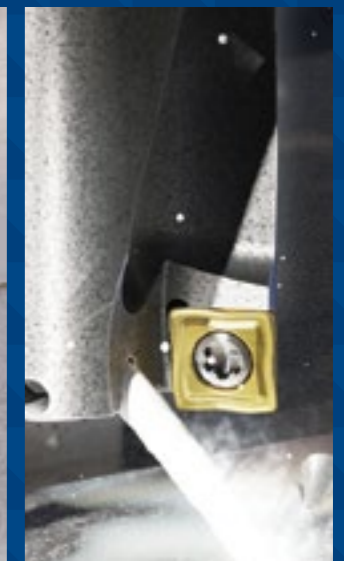

DRILLING



YG TURN
YG3115 NEW

First choice grade for high cutting speed in Steels



YG TURN
YG2025 NEW

High Cutting Speed for Stainless steels

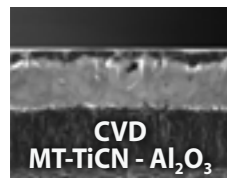

YG3115

P10 - P25

First choice grade for high cutting speed in Steels

- Suitable for mass production due to stable and predictable tool life
- Minimizing built up edge due to new post surface treatment in mild steels, low carbon steel and low carbon alloy steel.
- Best choice for both continuous as well as interrupted cuts

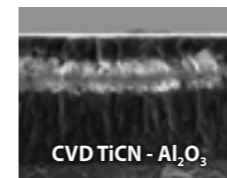
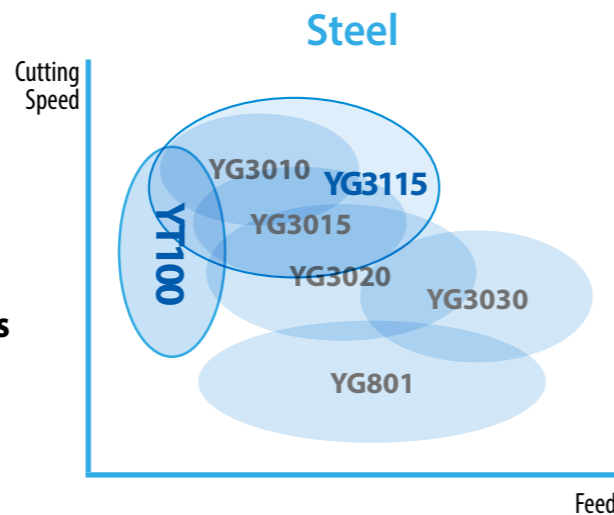

YG2025

M15 - M35

CVD grade for High Cutting Speed for Stainless steels

- Utilizing a new carbide substrate and new coating
- Excellent combination of wear resistance and chipping resistance
- Minimized built up edge due to post surface treatment

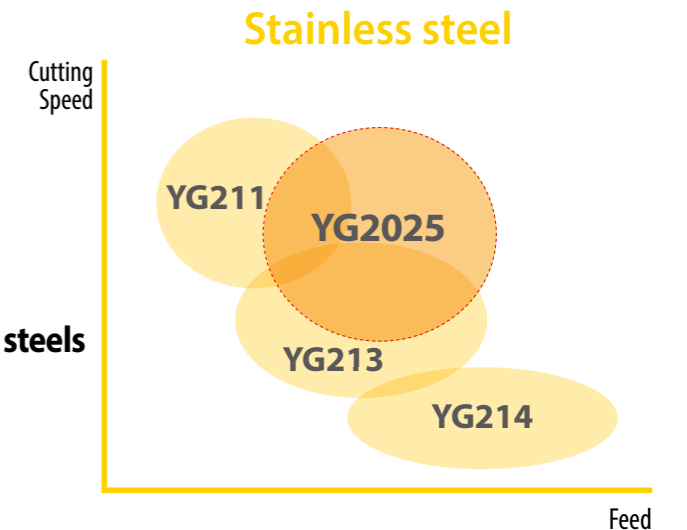

YG TURN YT100 NEW Cermet Turning Grade

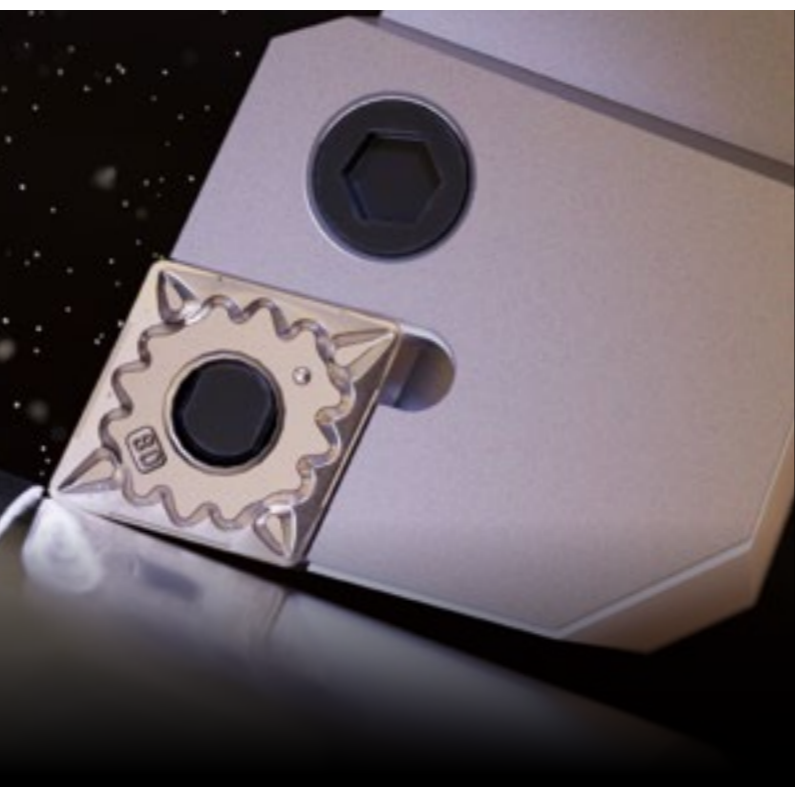

YG TURN UT, UH NEW Single sided inserts for heavy turning



Grades

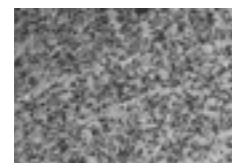

<Micro structure>

YT100 P10 - P20 M10 - M20 K10 - K20

- Enhanced wear resistance & chipping resistance
- Excellent fracture resistance
- Superior surface finish with special edge preparation

Chipbreakers

PSF

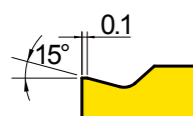

- For negative chip breaker insert
- 3 dimensional chip breakers give low cutting force
- For semi-finishing to semi-medium

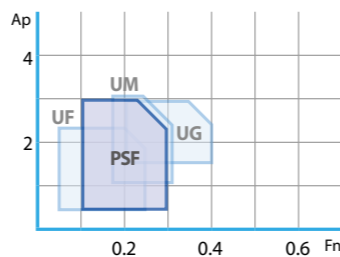

PF



- For positive chip breaker insert
- Excellent chip breaking at small depth of cut and low feed rate
- Good for low carbon contents steel in Finishing

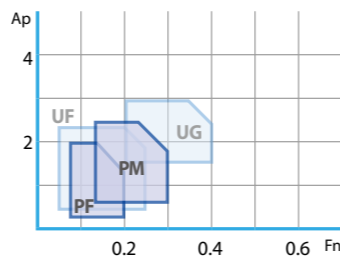

PM

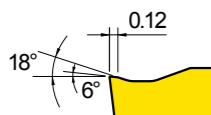

- For positive chip breaker insert
- High positive rake angle
- Good for low carbon contents steel
- For medium

Chipbreakers



UH

Low cutting force



UT

Heavy roughing

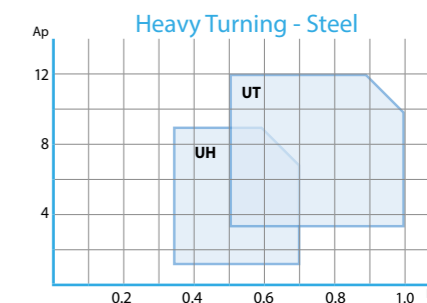

Features

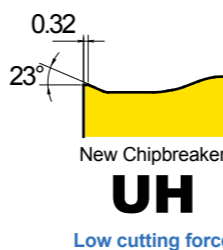

UH

Low cutting force

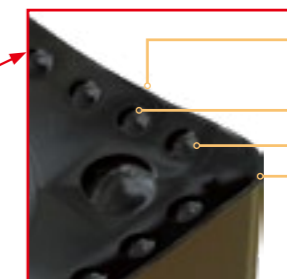
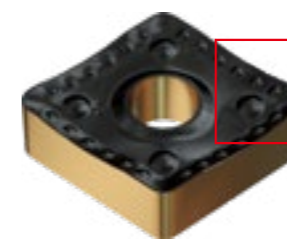

- 1 Reduce cutting force due to the helix angle on the cutting edge
- 2 The central dot helps chip breaking to be efficient
- 3 Decoration dot reduces friction area and helps heat release
- 4 Insert corner radius range available from 1.2mm to 2.4mm

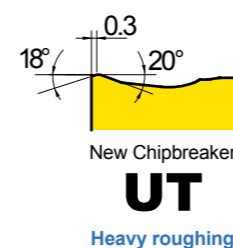

UT

Heavy roughing

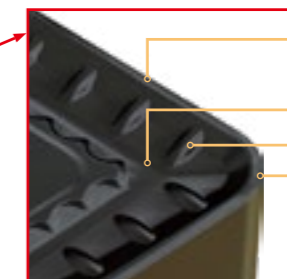

- 1 Reinforced edge type with high rigidity and is suitable for irregular surface cutting
- 2 Chip breaker is formed widely, suitable for heavy roughing application
- 3 Decoration dot reduces friction area and helps heat release
- 4 Insert corner radius range available from 1.2mm to 2.4mm

YG
NanoCut
Solid Miniature Turning
for small bore applications

NEW

Overview

At present, as demand for small parts (camera lens, mobile phone parts) and medical instruments (implants) increases, demand for small-diameter products capable of high-precision processing is increasing.

Application

- Turning of Small Bore Components
- Internal Turning(Boring), Grooving and Threading

Features

- Minimum Diameter(Boring & Profiling series) : Ø 1 mm
- Internal Coolant for Longer Tool life and Enhanced Chip Evacuation
- Secure Connection Design: Pin + Slant Positioning
- 9 Geometries for Various Applications

Benefits

- Reduced Machine Down Time
- Lower Machining Cost

Advantages of Nanocut

Easy Clamping

Secure and Simple system for fast change and fast locking

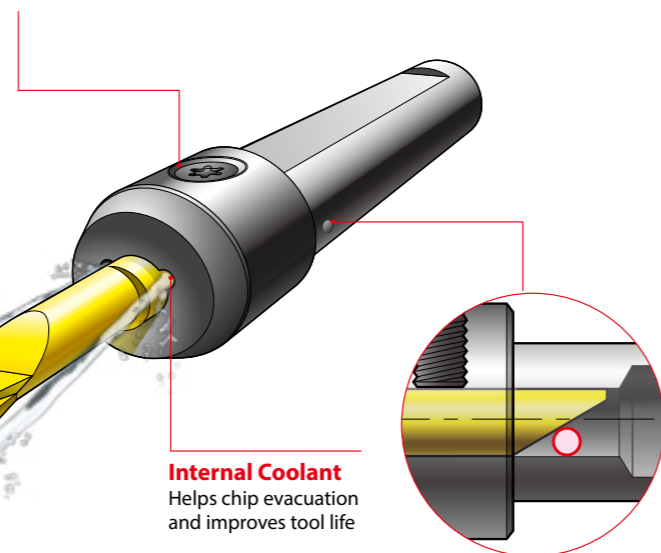

Internal Coolant
Helps chip evacuation and improves tool life

Secure Slant Connection
Ensures High repeatability for height and axial position

YG812 - Micro Grain Carbide Grade

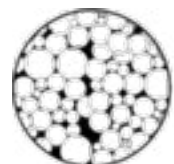

- P10 - P20
- M20 - M30
- K20 - K30
- S10 - S25

Submicron Grade Carbide Substrate Material for high toughness and wear resistance realizes high precision machining

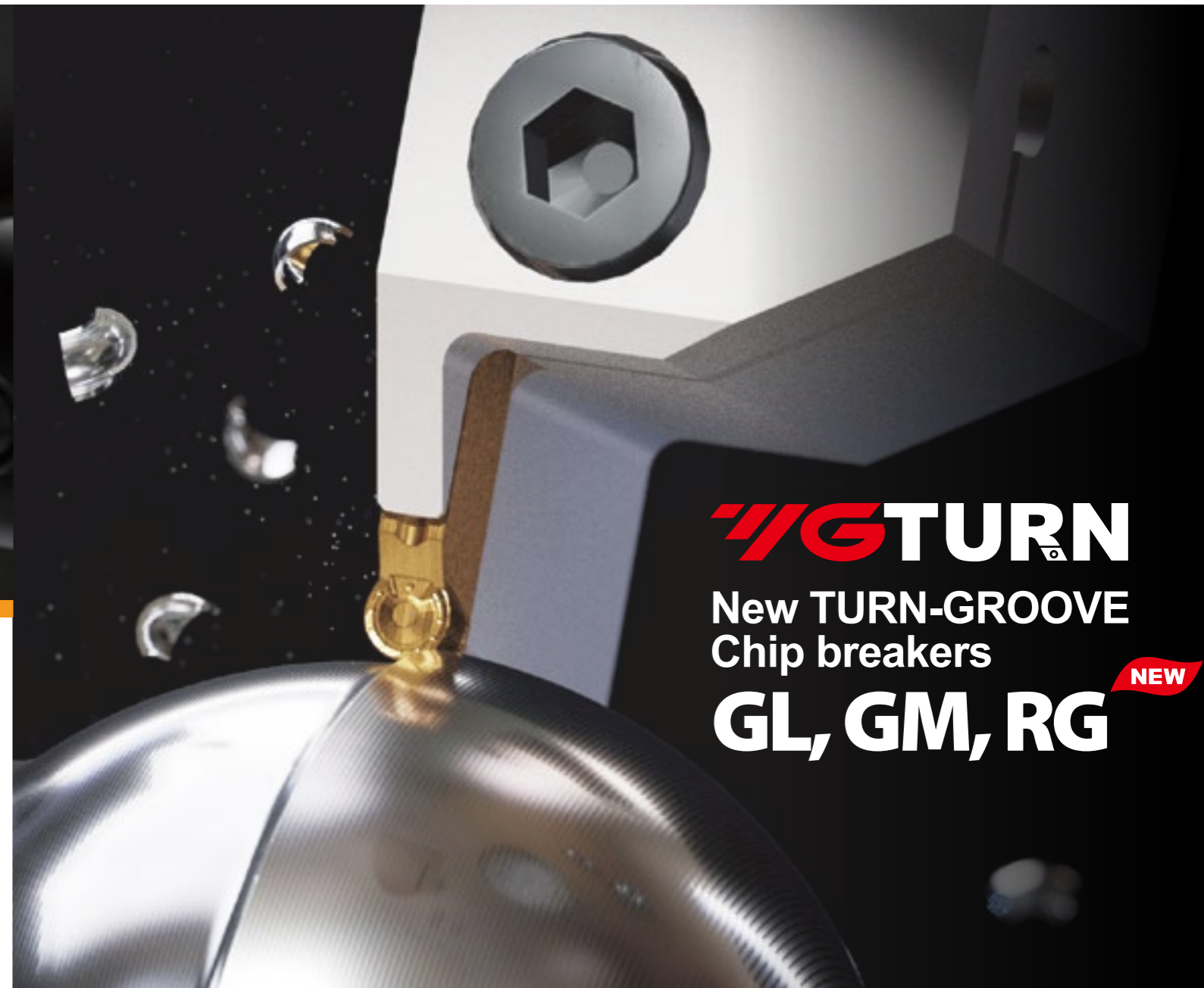

YG TURN
New TURN-GROOVE
Chip breakers
GL, GM, RG

NEW

TURN-GROOVE Chip breakers

	GL	GM	RG	
Turning & Grooving				<ul style="list-style-type: none"> • For External, Internal turning and grooving • Face grooving and Face turning • For low feed rate
				<ul style="list-style-type: none"> • For External, Internal turning and grooving • First choice face grooving and Face turning • For medium feed rate
				<ul style="list-style-type: none"> • For External, Internal turning and grooving • Full radius Insert for profiling



SM3
YG MILL **NEW**
TPKT

True 90 degree Shoulder Milling

- 3 Cutting Edges for Shoulder Milling
- High Positive Helical Cutting edge
- Higher Cost Efficiency than 2 Cutting edges
- Wide selection and Optimal Machining with Various Cutters and Inserts



SM6
YG MILL **NEW**
WNEX

6 cutting edges for Shouldering

Features

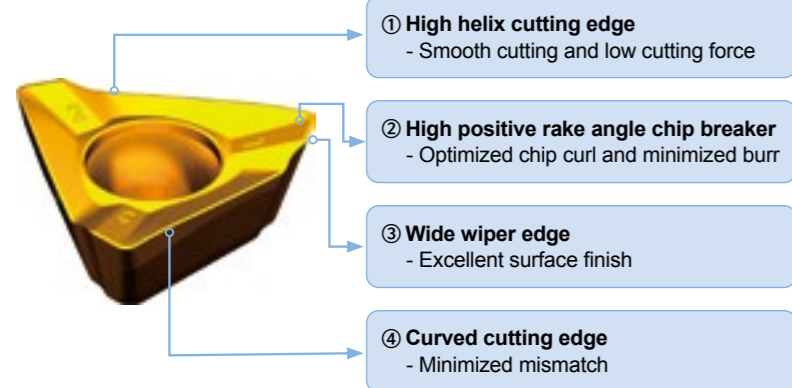

Applications



Key Technology

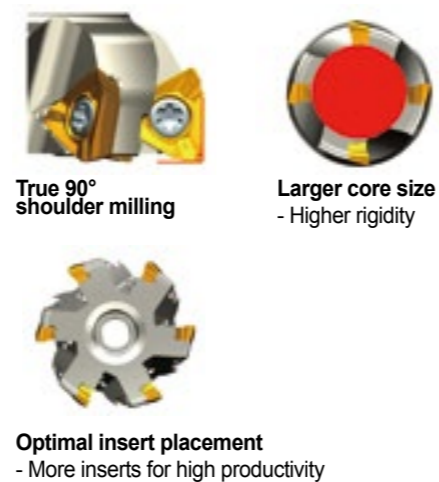

Applications



Features

- 6 cutting edges for Shouldering - High Cost-Efficiency
- High Positive Helical Cutting edge
- High Chipping Resistance with Reinforced cutting edge
- Ground Insert - High Precision Tolerance and Excellent Surface finish
- Diameter range : Ø32~Ø200
- Ap (max) : 7mm

Key Technology

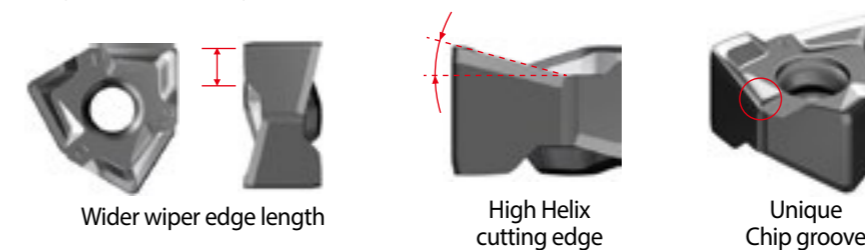



Features

- Economic square type 4 cutting edge insert
- One kind of insert in outer and inner pocket
- Twisted coolant channel and enlarged chip gullet for better chip evacuation
- Highly durable drill body due to high hardness and optimized material
- New post surface Treatment flute enables to improved chip evacuation in deeper machining

Key Technology

- Unique 1 chip curl per each flute
- True 4 cutting edges are available

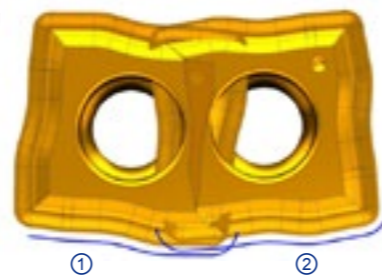

Click/Touch each page number and move to the very page!

	Contents	Page	
	Code System	External Turning Holder Code	16
		Internal Turning Holder Code	18
		Insert ISO Code System	20
		Grade Naming System	22
	Grades & Chipbreakers	Turning Grades Map	23
		Turning Grades	24
	Turning	Turning Chipbreakers	26
	Inserts Overview	Inserts Overview	29
	Inserts Product	Negative Inserts	30
		Positive Inserts	57
	Holders Overview	External Holders Overview	68
		Internal Holders Overview	70
	Holders Product	External Holders	72
		Internal Holders	93
	Parting & Grooving		
	Overview	Parting & Grooving Overview	118
	Inserts & Holders Product	Parting & Grooving Inserts	119
		Parting & Grooving Holders	120
	Code System	Code Keys - Boring Tool & Holder	129
	Overview	Boring Tool Insert & Holders Overview	130
		Boring Tool Series & Index	131
	Product	Boring Tool Inserts	132
		Boring Tool Holders	141

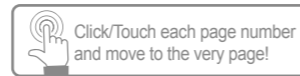

Contents		Page		
Milling 	Code Keys	Milling Cutter Code Keys	143	
		Insert ISO Code System	144	
	Grades & Chipbreakers	Milling Grades and Chipbreakers	146	
	Inserts	Milling Inserts Overview	148	
		Milling Inserts	149	
	Cutters	Milling Cutter Overview	176	
		Milling Cutters	178	
Drilling 	Overview	Drilling Grades and Chipbreakers	199	
	Product	Drilling Inserts	200	
		Drilling Holders	203	
Technical Information	Technical Information	ISO 13399 Terms	219	
			Hardness Conversion Table	220
			Formulas	221
	Cutting conditions	Recommended cutting conditions	222	
		Material Groups	224	
	Application Guide	Application Guide	241	
			Surface Roughness Guide	247
			Trouble Shooting	248
	Comparison Chart	Comparison Chart - Turning	251	
		Comparison Chart - Milling	253	
Search	ISO ↔ ANSI	254		
	Search	255		

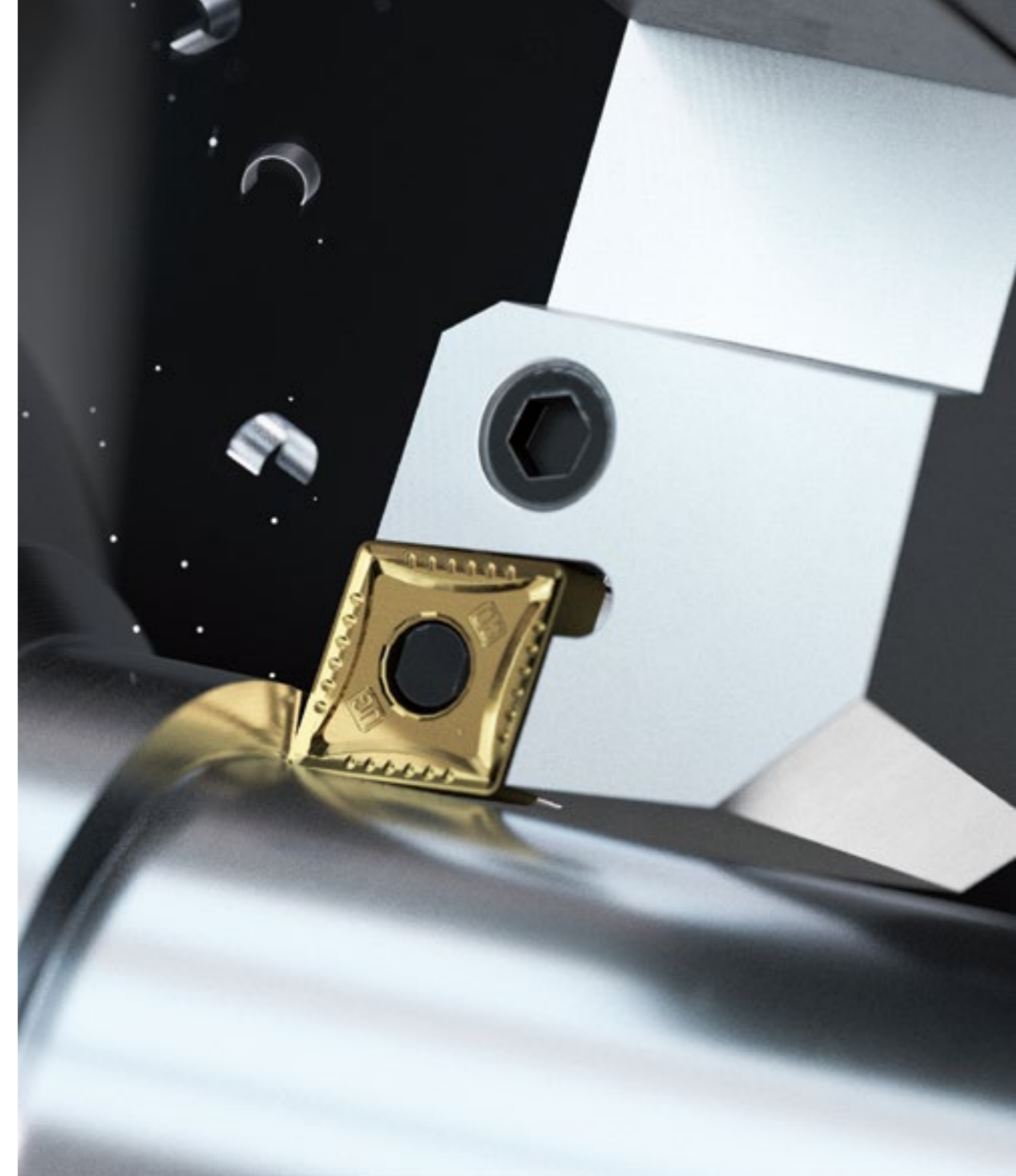

ISO TURNING

- Product Overview**
- Application Guide**
- Turning Inserts Overview**
- Turning Inserts**
- Turning Holders Overview**
- Turning Holders**





Scan this QR code to see our Turning Grades at work.

External Turning Holder Code

1	2	3	4	5	6	7	8	9	10
P	C	L	N	R	25	25	M	12	(C)
Clamping System	Insert Shape (1st Letter of Insert)	Tool Style	Insert Clearance (2nd Letter of Insert)	Tool Hand	Shank Height (H)	Shank Width (B)	Length (LF)	Insert Size	(Optional Clamp)

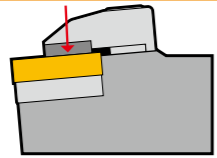
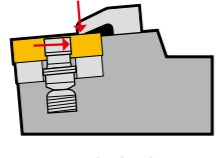
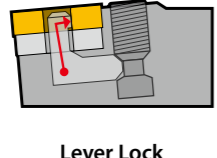
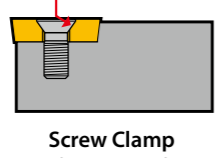
1 - Clamping System













Symbol	System
C	 Top Clamp (No Clamping Hole Insert)
M	 Multi lock (Straight Clamping Hole Insert)
P	 Lever Lock (Straight Clamping Hole Insert)
S	 Screw Clamp (Screw Clamping Hole Insert)
T (D, A)	 Double Clamp (Straight Clamping Hole Insert)

2, 4 - Insert Compatibility *



* Related to Insert Designation to check compatibility
* Refer to '1-shape' of page 20

3 - Tool Style

Approach Angle (KAPR)	Side Direction		End Direction
	Straight Shank	Offset Shank	
45°	D 	S 	
60°		T 	
62.5°	N 		
72.5°	V 		
75°	B 		K 
90°/91°	A 	G 	F 
93°		J 	U
95°		L (Both Direction) 	
107.5°		H 	

External Turning Holder Code

1	2	3	4	5	6	7	8	9
S	D	J	C	R	20	20	K	11
Clamping System	Insert Shape (1st Letter of Insert)	Tool Style	Insert Clearance (2nd Letter of Insert)	Tool Hand	Shank Height (H)	Shank Width (B)	Length (LF)	Insert Size

5 - Hand Direction

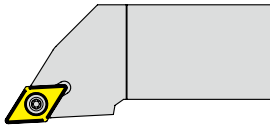
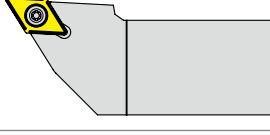
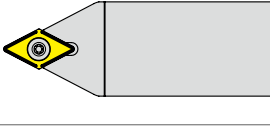
Symbol	Hand Direction
R	Right Hand 
L	Left Hand 
N	Neutral 

6, 7 - Shank Height (H) Shank Width (B)

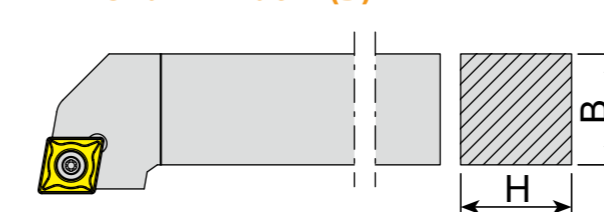

8 - Length (LF)

Symbol	Length (mm)	Symbol	Length (mm)
E	70	Q	180
F	80	R	200
H	100	S	250
K	125	T	300
M	150	U	350
P	170	V	400

9 - Insert Size *

Examples	is Compatible with...
PCLNR 2525M 12	CNMG 1204**
SCLCR 2020K 09	CCMT 09T3**
TWLNR 2525M 08	WNMG 0804**

* Related to Insert Designation to check compatibility

(10 - Optional Clamp)

Symbol	Optional Clamp
C	Included

Internal Turning Holder Code

*Metric

1	2	3	4	5	6	7	8	9	10	
A	32	S	-	P	W	L	N	R	12	(C)
Coolant & Material	Shank Diameter (DCON)	Legth (LF)	Clamping System	Insert Shape (1st Letter of Insert)	Tool Style	Insert Clearance (2nd Letter of Insert)	Tool Hand	Insert Size	(Optional Clamp)	

1 - Coolant and Tool Material

Symbol	Internal Coolant	Tool Material
A	O	Steel
S	X	
E	O	Carbide
C	X	Carbide

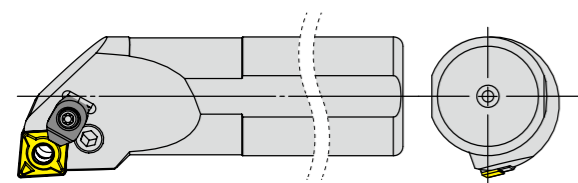

2 - Shank Diameter (DCON)



3 - Length (LF)

Symbol	Length (mm)	Symbol	Length (mm)
E	70	Q	180
F	80	R	200
H	100	S	250
K	125	T	300
M	150	U	350
P	170	V	400

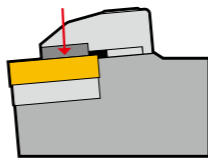
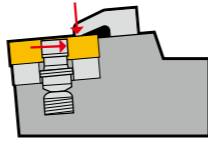
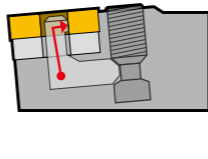
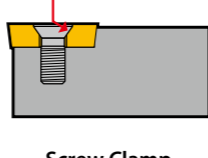
4 - Clamping System

Symbol	System
C	 Top Clamp (No Clamping Hole Insert)
M	 Multi lock (Straight Clamping Hole Insert)
P	 Lever Lock (Straight Clamping Hole Insert)
S	 Screw Clamp (Screw Clamping Hole Insert)
T (D, A)	 Double Clamp (Straight Clamping Hole Insert)

Internal Turning Holder Code

*Metric

1	2	3	4	5	6	7	8	9	
A	25	R	-	S	C	L	C	R	09
Coolant & Material	Shank Diameter (DCON)	Legth (LF)	Clamping System	Insert Shape (1st Letter of Insert)	Tool Style	Insert Clearance (2nd Letter of Insert)	Tool Hand	Insert Size	

6 - Tool Style

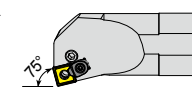
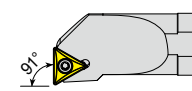
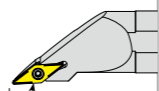
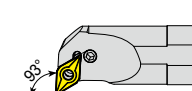
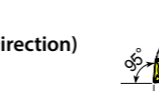
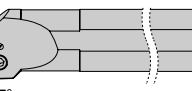
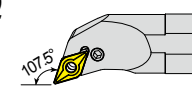
Approach Angle (KA/PR)	Side Direction	End Direction
	Offset Shank	
75°		K 
91°		F 
93°	J 	U 
95°	L (Both Direction) 	
107.5°		Q 

8 - Hand Direction

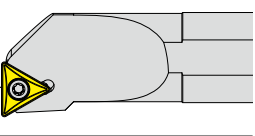
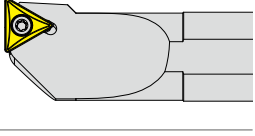
Symbol	Hand Direction
R	Right Hand 
L	Left Hand 

9 - Insert Size *

Examples	is Compatible with...
PCLNR 2525M 12	CNMG 1204**
SCLCR 2020K 09	CCMT 09T3**
TWLNLR 2525M 08	WNMG 0804**

* Related to Insert Designation to check compatibility

5, 7 - Insert Compatibility *



* Related to Insert Designation to check compatibility
* Refer to '1-Shape' of page 20

(10 - Optional Clamp)

Symbol	Optional Clamp
C	Included

Insert ISO Code System

*Metric : According to ISO 1832

1	2	3	4	5	6	7	8	9
C	N	M	G	12	04	08	-UG	YG3115
Shape	Clearance	Tolerance	Clamping & Chipbreaker	Insert Size	Insert Thickness	Corner Radius	Chipbreaker Geometry	Grade

1 - Shape

Symbol	Shape	
H	Hexagonal	
O	Octagonal	
P	Pentagonal	
S	Square	
T	Triangular	
C	Rhombic 80°	
D	Rhombic 55°	
V	Rhombic 35°	
W	Trigon	
L	Rectangular	
K	Parallelogram 55°	
R	Round	

2 - Relief Angle (AN)

Symbol	Relief Angle (AN)	
N	No Relief Angle	
B	Relief 5°	
C	Relief 7°	
P	Relief 11°	
D	Relief 15°	
E	Relief 20°	
F	Relief 25°	
O	Special	

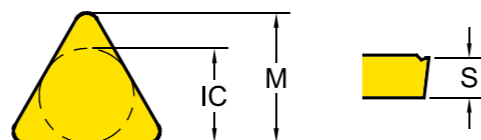

3 - Tolerance Class

Symbol	Inner Circle IC (mm)	Nose Height M (mm)	Thickness S (mm)
C	± 0.025	± 0.013	± 0.025
E	± 0.025	± 0.025	± 0.025
G	± 0.025	± 0.025	± 0.13
H	± 0.013	± 0.013	± 0.025
K*	± 0.05~0.15*	± 0.013	± 0.025
M*	± 0.05~0.15*	± 0.08~0.2*	± 0.13
U*	± 0.08~0.25*	± 0.13~0.38*	± 0.13

*Tolerance is different by insert IC size. Please see ISO 1832

4 - Clamping & Chipbreaker

Symbol	Clamping	Chipbreaker	Figure
N	No clamping hole	X	
R		One Face	
A	Cylindrical Clamping hole	X	
M		One Face	
G		Both Faces	
W	Screw Hole	X	
T		One Face	
U		Both Faces	
X		Special	

Insert ISO Code System

*Inch

1	2	3	4	5	6	7	8	9
C	N	M	G	4	3	2	-UG	YG3115
Shape	Clearance	Tolerance	Clamping & Chipbreaker	Insert Size	Insert Thickness	Corner Radius	Chipbreaker Geometry	Grade

5 - Insert Size

Metric							Inner Circle IC (mm)	Inch
S	T	C	D	V	W	R		
06	11	06	07	11			6.35	2
07	13	08	09	13	15		7.94	2.5
09	16	09	11	16	06	09 (00)	9.525	3
12	22	12	15	22	08	12 (00)	12.7	4
15	27	16	19	27	10		15.875	5
19	33	19	23	33	13		19.05	6
25		25					25.4	8
						06 (M0)	6	
						08 (M0)	8	
						10 (M0)	10	
						12 (M0)	12	
						16 (M0)	16	

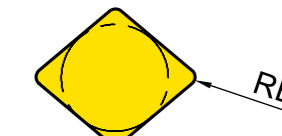
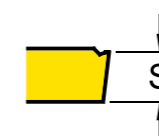

6 - Insert Thickness (S)

Metric	Thickness - S (mm)	Inch
T1	1.98	1.2
02	2.38	1.5
03	3.18	2
T3	3.97	2.5
04	4.76	3
05	5.56	3.5
06	6.35	4
07	7.94	5
09	9.525	6

7 - Corner Radius (RE)

Metric	Corner Radius - RE (mm)	Inch
01	0.1	03
02	0.2	05
04	0.4	1
08	0.8	2
12	1.2	3
16	1.6	4
20	2.0	5
24	2.4	6

Grade Naming System

1	2	3	4	5	(6)
YG	3	1	1	5	(G)
YG Brand	Workpiece Material	Grade Version	Application Range (1st Digit)	Application Range (2nd Digit)	Minor Variation
Carbide CVD (4 Digits)	●	●	●	●	YG3115
Carbide PVD (3 Digits)	●	●	●		YG211
Carbide Uncoated (2 Digits)	●	●			YG10



1 - YG Brand

2 - Workpiece Material

Symbol	Workpiece Material	Turning	Milling	Drilling	Parting
1	K Cast Iron or N Non-Ferrous	●			
2	M Stainless Steel	●			
3	P Steel	●			
4	S Superalloys	●			
5	K Cast Iron or N Non-Ferrous		●	●	●
6	M Stainless Steel or Universal		●	●	●
7	P Steel		●	●	●
8	Universal	●			
0	Hardened Steel		●		

3 - Grade Version

4 & 5 - Application Range

Symbol	Description
05	 Stable Wear Resistant Grade Stable Application Continuous Cut Finishing
10	
15	
20	
25	
25	 General Balanced Grade High Versatility General Application
30	
35	
40	
45	
	 Unstable Tougher Grade Unstable Application Interrupted Cut Chipping Resistance Roughing

(6) - (Minor Variation)

G - Gold Coated Version

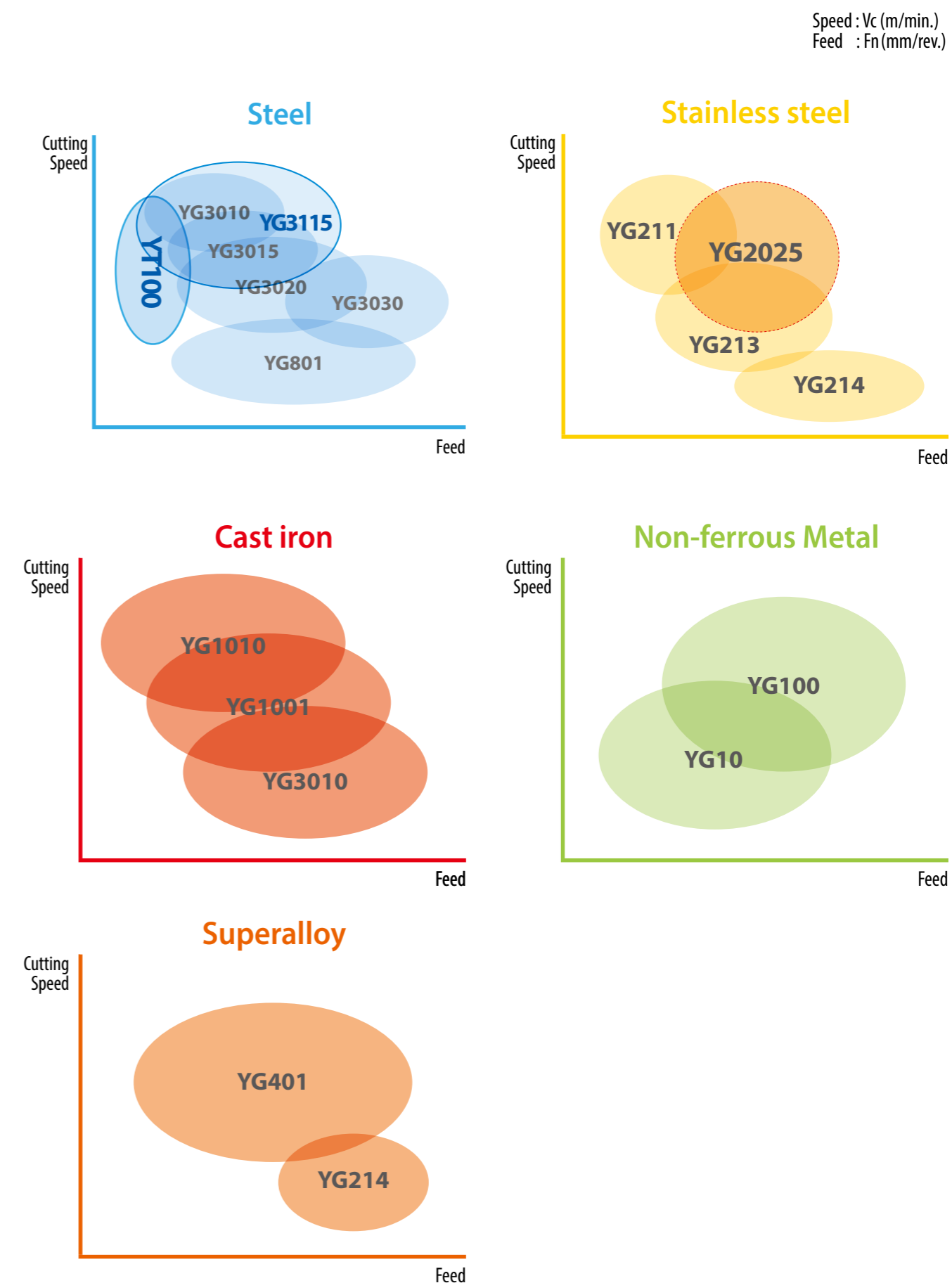

Product Overview

Turning Grades Map





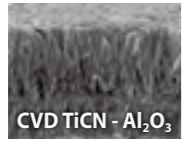
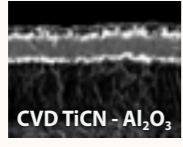
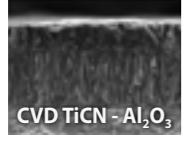

Product Overview
Turning Grades

Turning Grades	P Steel				M Stainless steel			K Cast iron			N Non-ferrous		S Superalloys	
	P10	P20	P30	P40	M10	M20	M30	K10	K20	K30	N10	N20	S10	S20
CVD	YG1010							1010						
	YG1001	1001						1001						
	YG3010	3010						3010						
	YG3015	3015												
	YG3115	3115												
	YG3020	3020												
	YG3030	3030												
PVD	YG2025					2025								
	YG801	801												
	YG211					211								
	YG213					213								
	YG214					214							214	
Cermet	YG401												401	
	YT100	YT100				YT100		YT100						
DLC	YG100										100			
	YG10										10			

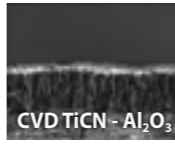
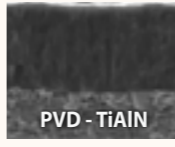
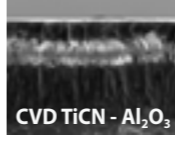
YG1010 K05 - K15		First Choice for Cast Iron • Effective coating structure enables high speed machining • Special post treatment for improved chipping resistance
YG1001 P01 - P10 K10 - K25		Stable Machining of Cast Iron • Substrate especially designed for high wear resistance • Thick Al ₂ O ₃ layer ensures good wear resistance at high cutting speeds including dry machining
YG3010 P05 - P20 K15 - K35		First choice for Finishing Steels, and Ductile Cast iron • Finishing and light machining of steel under in stable condition • New Al ₂ O ₃ coating technology and excellent surface smoothness increase wear resistance and chipping resistance
YG3015 P10 - P25		Balanced Productivity for Continuous cut • High wear resistance and improved toughness ensures high productivity with less trouble
NEW YG3115 P15 - P25		First choice grade for high cutting speed in Steels • Suitable for mass production due to stable and predictable tool life • Minimizing built up edge due to new post surface treatment in mild steels, low carbon steel and low carbon alloy steel. • Best choice for both continuous as well as interrupted cuts

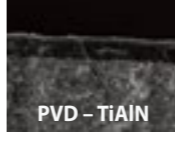
Product Overview
Turning Grades

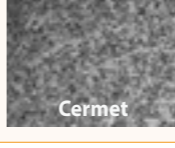
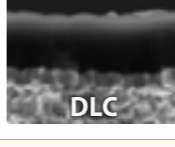
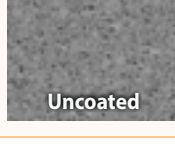
YG3020 P15 - P30		First Choice Grade for General Steel Application • Substrate especially designed for good toughness • Excellent surface smoothness increases wear resistance and reliability
YG3030 P20 - P35		Interrupted Cutting of Steel and Stainless steel • Substrate for heavy roughing in mild steel and low carbon alloy steel • New Al ₂ O ₃ technology and optimized surface treatment achieves a good balance between wear resistance and chipping resistance
YG801 P10 - P30		for Carbon Steel with Low Cutting Speed • Recommended for mild steel and boring application • Substrate and special PVD coating for excellent wear resistance
NEW YG2025 M15 - M35		CVD grade for High Cutting Speed for Stainless steel • Utilizing a new carbide substrate and new coating • Excellent combination of wear resistance and chipping resistance • Minimized built up edge due to post surface treatment
YG211 M05 - M25		High wear Resistance Grade for Stainless steel • Finishing Stainless steel
YG213 M20 - M35		First Choice Grade on Low Cutting Speed of Stainless steel • First choice on Stainless steel for Low cutting speed • For Medium to low cutting speed
YG214 M30 - M40 S25 - S30		Heavy Interrupted cut for Stainless steel • For Heavy Interrupted cut on Stainless steel • Minimize risk of Mechanical fracture or Chipping
YG401 S10 - S20		PVD Turning Grade for HRSA • Highly heat-resistant TiAlSiN structure for excellent wear resistance • Greatly improved film coating realizes excellent boundary defect resistance • Top coating layer provides a smooth surface and lubricant effect
NEW YT100 P10 - P20 M10 - M20 K10 - K20		New Generation Cermet Grade • Enhanced wear resistance & chipping resistance • Excellent fracture resistance • Superior surface finish with special edge preparation
YG100 N05 - N25		First Choice Grade for Aluminum with DLC Coating • Submicron carbide for high wear resistance • DLC coating minimizes Built Up Edge tendency. • Improve tool life in sticky non-ferrous alloy
YG10 N05 - N25		Uncoated Grade for General Aluminum • Substrate consisted of submicron carbide for high wear resistance • Shining surface to prevent built up edge

Turning Chipbreakers - Negative

P	M	K	N	S	Feed	Fn (mm/rev.)						
						0	0.1	0.2	0.3	0.4	0.5	0.6
P					UF	Finishing 16° Fn: 0.05~0.25 Ap: 1.0~2.5						
P					UL	Semi Finishing and sticky materials 27° 18° 0.1 Fn: 0.1~0.3 Ap: 1.0~3.0						
P					UM	Medium & Unstable conditions 0.13 16° Fn: 0.15~0.3 Ap: 1.0~3.0						
P					UG	First Choice for Medium (Stable conditions) 20° 6° 0.23 Fn: 0.2~0.4 Ap: 1.0~3.0						
P					NEW PWM	Wiper-Medium 0.18 5° 18° Fn: 0.1~0.5 Ap: 0.8~3.5						
P					NEW UH	Low cutting force 0.32 23° Fn: 0.35~0.7 Ap: 2.0~9.0						
P					NEW UT	Heavy roughing 18° 0.3 20° Fn: 0.5~1.0 Ap: 4.0~12.0						
P		K			UC	Medium Roughing and First choice for Cast iron 14° 0.2 Fn: 0.2~0.4 Ap: 1.0~4.0						
P		K			UR	Roughing and Heavy interrupted cut 0.35 17° Fn: 0.3~0.5 Ap: 1.0~5.0						
		K			..MA	Cast iron Heavy Roughing Fn: 0.15~0.50 Ap: 1.0~5.0						

Depth of Cut Ap (mm)

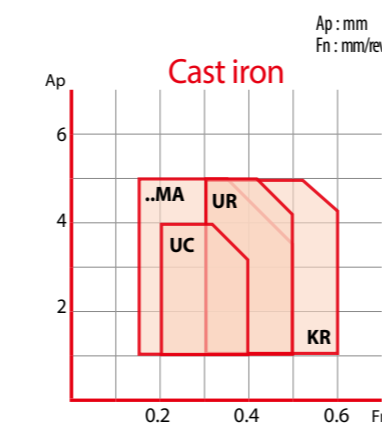
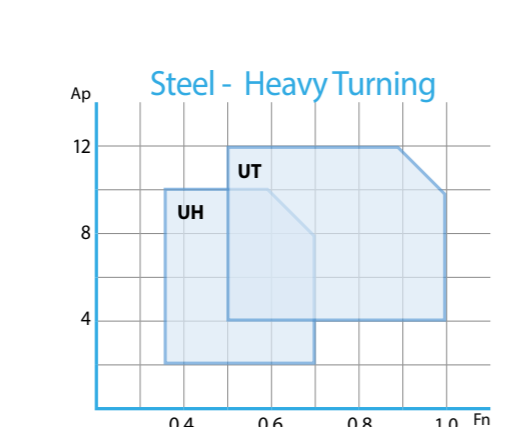
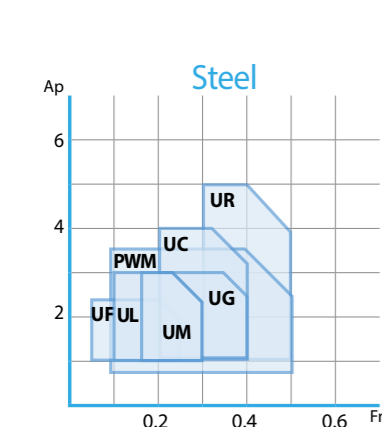

*Insert : CNMG120408

*Insert : CNMM190616

*Insert : CNMG120408

Turning Chipbreakers - Negative

P	M	K	N	S	Feed	Fn (mm/rev.)						
						0	0.1	0.2	0.3	0.4	0.5	0.6
		K			KR	Cast Iron Heavy Roughing 19° 0.50 Fn: 0.3~0.6 Ap: 1.0~5.0						
	M			S	MF	Stainless steel Finishing 18° Fn: 0.07~0.30 Ap: 0.2~1.5						
	P	M		S	MM	Stainless steel Medium and Low Carbon Steel 19° 18° 0.17 Fn: 0.20~0.35 Ap: 1.0~3.5						
	M			S	MG	Stainless steel General 10° 0.27 Fn: 0.20~0.40 Ap: 1.0~4.0						
	M			S	MR	Stainless steel Roughing 8° 0.40 Fn: 0.30~0.55 Ap: 2.0~5.5						
				S	SF	HRSA Finishing 20° Fn: 0.1~0.25 Ap: 0.2~1.0						
				S	SM	HRSA Medium 15° Fn: 0.15~0.30 Ap: 0.5~3.0						
				S	SR	Roughing for HRSA 8° 0.40 Fn: 0.30~0.55 Ap: 2.0~5.5						
	P	M	K		NEW PSF	Cermet Finishing 15° 0.1 Fn: 0.10~0.30 Ap: 0.6~3.0						
	P	M	K		NEW -C	Cermet Medium 14° 0.2 Fn: 0.20~0.40 Ap: 1.0~3.5						

Depth of Cut Ap (mm)

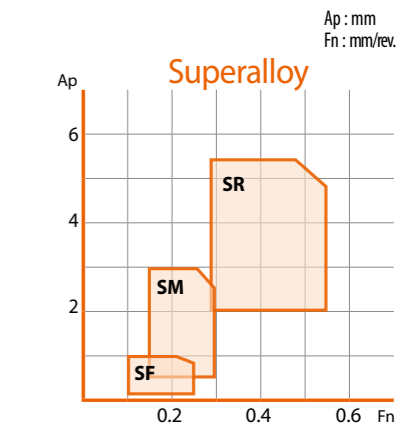
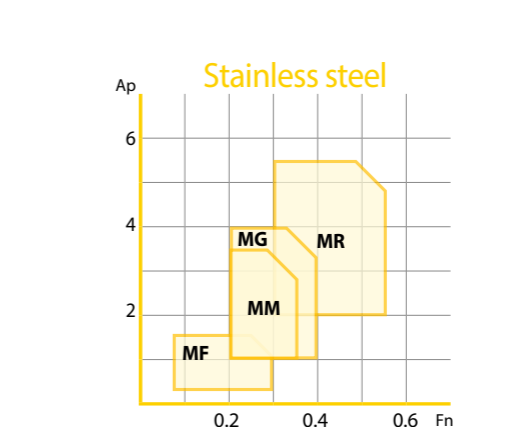
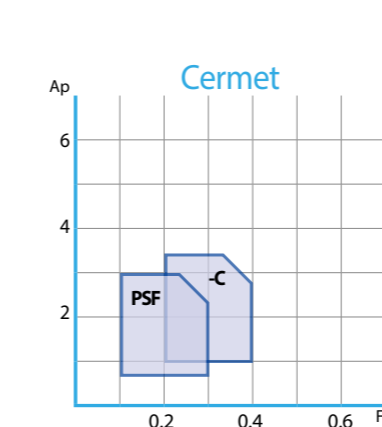

*Insert : CNMG120408 / TNGG160408

*Insert : CNMG120408

*Insert : CNMG120408

Turning Chipbreakers - Positive

P	M	K	N	S	Material	Application	Feed	
							Fn (mm/rev.)	Ap (mm)
			N		AL	Aluminum application 28°	0.02~0.30	0.1~5.0
P	M				UF	Finishing application 10°	0.05~0.25	0.5~2.0
P		K			UG	Medium application 0.15	0.15~0.30	0.5~2.5
	M				NEW MF	Stainless steel Finishing 6°	0.06~0.25	0.1~2.0
	M				NEW MM	Stainless steel Medium 18°/6°/0.12	0.08~0.25	0.25~3.0
	M				NEW SF	HRSA Finishing 18°	0.03~0.20	0.1~2.5
P	M	K			NEW PF	Cermet Finishing 6°	0.06~0.25	0.1~2.0
P	M	K			NEW PM	Cermet Medium 18°/6°/0.12	0.08~0.25	0.25~3.0

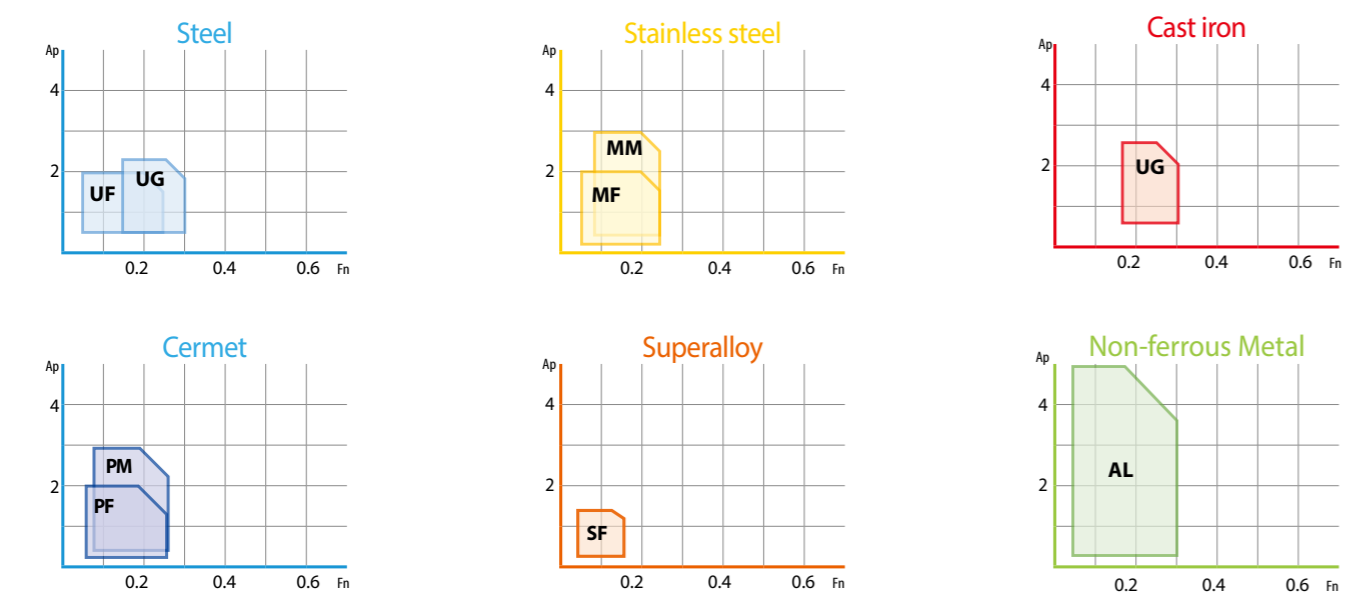

*Insert : CCMT09T304

Click/Touch each page number and move to the very page!

Turning Inserts Overview

Negative Inserts

Recommended Cutting Conditions : p.222

Shape	Series	Size & Thickness				Page	
		0903	0904	1204	1606 1906		
C	CNMA			1204	1606 1906	30	
	CNMG	0903	0904	1204	1606 1906		
	CNGG			1204			
	CNMM			1204	1606 1906		
D	DNMA			1504 1506		35	
	DNMG		1104	1504 1506			
	DNGG			1504 1506			
	DNMM			1506			
K	KNUX				1604	41	
S	SNMA			1204	1506	1906	42
	SNMG	0903		1204		1906	
	SNMM				1506	1906	
T	TNMA				1604		47
	TNMG				1604	2204	
	TNGG				1604		
V	VNMA				1604		51
	VNMG				1604		
W	WNMA			0804			53
	WNGG			0804			
	WVMG	0604		0804			

Positive Inserts

Shape	Series	Size & Thickness				Page	
		0602	0702	0803 10T3	1204		
C	CCGT	0602		09T3	1204	57	
	CCMT	0602		09T3	1204		
D	DCGT		0702		11T3	59	
	DCMT		0702		11T3		
R	RCMT	0602	0803	10T3	1204	61	
	RCMX					1606 2006	
S	SCGT			09T3		63	
	SCMT			09T3	1204		
T	TCGT			1102		16T3	64
	TCMT			1102		16T3	
V	VBGT / VBMT				1103	1604	66
	VCGT / VCMT				1103	1604	67

Turning Inserts - Negative
CNMA / CNMG (80° Rhombic)

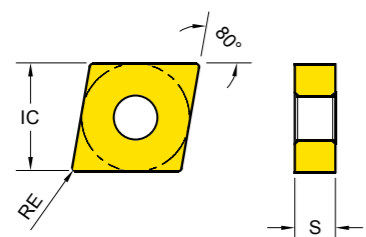

Series	IC	S
CN** 0903	9.525	3.18
CN** 0904	9.525	4.76
CN** 1204	12.700	4.76
CN** 1606	15.875	6.35
CN** 1906	19.050	6.35

EDP 2200.. ● : Stock item ○ : Order made item

CNMA CNMG	Designation	RE	Fn (mm/rev.)	Ap (mm)	EDP 2200..																
					K10	P05	P10	P15	P10	P20	P30	P20	M25	M15	M30	M40	S10	P15	M15	N20	N20
					YG1010	YG1001	YG3010	YG3015	YG3115	YG3020	YG3030	YG801	YG2025	YG211	YG213	YG214	YG401	YT100	YG100	YG10	
..MA 	CNMA 120404	0.4	0.15~0.50	0.5~5.0	●	○	○														
	CNMA 120408	0.8	0.15~0.50	1.0~5.0	●	○	○														
	CNMA 120412	1.2	0.15~0.50	1.5~5.0	●	○	○														
	CNMA 120416	1.6	0.15~0.50	2.0~5.0	●	○	○														
	CNMA 160612	1.2	0.15~0.50	1.5~5.0	●	○	○														
	CNMA 160616	1.6	0.15~0.50	2.0~5.0	●	○	○														
	CNMA 190612	1.2	0.15~0.50	1.5~9.0	●	○	○														
CNMA 190616	1.6	0.15~1.00	3.0~10.0	●	○	○															
-UF 	CNMG 120404 - UF	0.4	0.05~0.25	0.5~2.5			○		●	●	●	○									
	CNMG 120408 - UF	0.8	0.05~0.25	1.0~2.5			○		●	●	●										
	CNMG 120412 - UF	1.2	0.05~0.25	1.5~2.5			○		●	●	●										
-UL 	CNMG 090308 - UL	0.8	0.10~0.30	1.0~2.5		○			●	●	●										
	CNMG 090312 - UL	1.2	0.10~0.30	1.5~2.5		○			●	●	●										
	CNMG 090408 - UL	0.8	0.10~0.30	1.0~2.5		○			●	●	●										
	CNMG 090412 - UL	1.2	0.10~0.30	1.5~2.5		○			●	●	●										
	CNMG 120404 - UL	0.4	0.10~0.30	0.5~3.0		○			●	●	●										
	CNMG 120408 - UL	0.8	0.10~0.30	1.0~3.0		○			●	●	●										
	CNMG 120412 - UL	1.2	0.10~0.30	1.5~3.0		○			●	●	●										
-UM 	CNMG 120404 - UM	0.4	0.15~0.30	0.5~3.0		●	●				●	●									
	CNMG 120408 - UM	0.8	0.15~0.30	1.0~3.0		●	●	○			●	●									
	CNMG 120412 - UM	1.2	0.15~0.30	1.5~3.0		●	●				●	●									

Turning Inserts - Negative
CNMG (80° Rhombic)

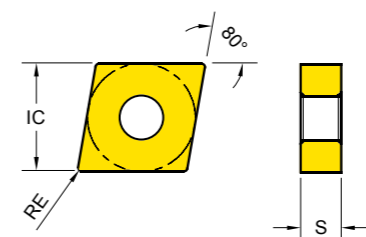

Series	IC	S
CN** 0903	9.525	3.18
CN** 0904	9.525	4.76
CN** 1204	12.700	4.76
CN** 1606	15.875	6.35
CN** 1906	19.050	6.35

EDP 2200.. ● : Stock item ○ : Order made item

CNMG	Designation	RE	Fn (mm/rev.)	Ap (mm)	EDP 2200..																
					K10	P05	P10	P15	P10	P20	P30	P20	M25	M15	M30	M40	S10	P15	M15	N20	N20
					YG1010	YG1001	YG3010	YG3015	YG3115	YG3020	YG3030	YG801	YG2025	YG211	YG213	YG214	YG401	YT100	YG100	YG10	
-UG 	CNMG 120404 - UG	0.4	0.20~0.40	0.5~3.0	●	○	○														
	CNMG 120408 - UG	0.8	0.20~0.40	1.0~3.0	●	○	○														
	CNMG 120412 - UG	1.2	0.20~0.40	1.5~3.0	●	○	○														
	CNMG 160608 - UG	0.8	0.20~0.40	1.0~5.0	●	○	○														
	CNMG 160612 - UG	1.2	0.20~0.40	1.5~5.0	●	○	○														
	CNMG 160616 - UG	1.6	0.30~0.50	2.0~5.0	●	○	○														
	CNMG 190608 - UG	0.8	0.20~0.60	1.0~6.0	●	○	○														
CNMG 190612 - UG	1.2	0.20~0.60	1.5~6.0	●	○	○															
-PWM 	CNMG 120404 - PWM	0.4	0.10~0.50	0.5~3.5		●			●	●	●										
	CNMG 120408 - PWM	0.8	0.10~0.50	0.8~3.5		●			●	●	●										
	CNMG 120412 - PWM	1.2	0.10~0.50	1.0~3.5		●			●	●	●										
-UC 	CNMG 120404 - UC	0.4	0.20~0.40	0.5~4.0		●	○	○				●	●	●							
	CNMG 120408 - UC	0.8	0.20~0.40	1.0~4.0		●	○	○				●	●	●							
	CNMG 120412 - UC	1.2	0.20~0.40	1.5~4.0		●	○	○				●	●	●							
-UR 	CNMG 120408 - UR	0.8	0.30~0.50	1.0~5.0		●	○	○				●	●	●							
	CNMG 120412 - UR	1.2	0.30~0.50	1.5~5.0		●	○	○				●	●	●	○						
	CNMG 120416 - UR	1.6	0.30~0.50	2.0~5.0		●	○	○				●	●	●							
	CNMG 160608 - UR	0.8	0.30~0.50	1.0~5.0		●	○	○				●	●	●							
	CNMG 160612 - UR	1.2	0.30~0.50	1.5~5.0		●	○	○				●	●	●							
	CNMG 160616 - UR	1.6	0.30~0.50	2.0~5.0		●	○	○				●	●	●							
	CNMG 190608 - UR	0.8	0.30~0.80	3.0~9.0		●	○	○				●	●	●							
	CNMG 190612 - UR	1.2	0.30~0.80	3.0~9.0		●	○	○				●	●	●							
	CNMG 190616 - UR	1.6	0.30~0.80	3.0~9.0		●	○	○				●	●	●							
	CNMG 120408 - KR	0.8	0.30~0.60	1.0~5.0		●	○	○				●	●	●							
CNMG 120412 - KR	1.2	0.30~0.60	1.5~5.0		●	○	○				●	●	●								
CNMG 160612 - KR	1.2	0.30~0.60	1.5~6.0		●	○	○				●	●	●								
CNMG 160616 - KR	1.6	0.30~0.60	2.0~6.0		●	○	○				●	●	●								
CNMG 190612 - KR	1.2	0.30~1.00	3.0~9.0		●	○	○				●	●	●								

Turning Inserts - Negative TNUX (60° Triangle)

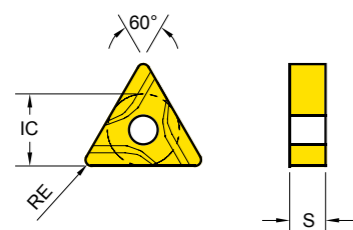

Series	IC	S
TN** 1604	9.525	4.76

EDP 2200.. ● : Stock item ○ : Order made item

TNUX	Designation	RE	Fn (mm/rev.)	Ap (mm)	EDP 2200..															
					YG1010	YG1001	YG3010	YG3015	YG3115	YG3020	YG3030	YG801	YG2025	YG211	YG213	YG214	YG401	YT100	YG100	YG10
..UX 	TNUX 160404 L	0.4	0.10~0.30	0.5~4.0		○	●	●	●	○										
	TNUX 160408 L	0.8	0.10~0.40	1.0~5.0		○	●	●	●	○		○								
..UX 	TNUX 160404 R	0.4	0.10~0.30	0.5~4.0		○	●	●	●	●										
	TNUX 160408 R	0.8	0.10~0.40	1.0~5.0		○	●	●	●	●										

Turning Inserts - Negative VNMA / VNMG (35° Rhombic)

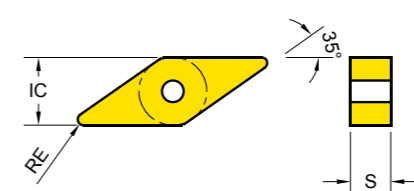

Series	IC	S
VN** 1604	9.525	4.76

EDP 2200.. ● : Stock item ○ : Order made item

VNMA VNMG	Designation	RE	Fn (mm/rev.)	Ap (mm)	EDP 2200..															
					YG1010	YG1001	YG3010	YG3015	YG3115	YG3020	YG3030	YG801	YG2025	YG211	YG213	YG214	YG401	YT100	YG100	YG10
..MA 	VNMA 160408	0.8	0.15~0.40	1.0~5.0	●	○	○													
					1573	0162	1275													
-UF 	VNMG 160404 - UF	0.4	0.05~0.25	0.5~2.5		○	●	●	●	○										
	VNMG 160408 - UF	0.8	0.05~0.25	1.0~2.5		○	●	●	●	○										
-UL 	VNMG 160404 - UL	0.4	0.10~0.30	0.5~3.0		○	●	●	●											
	VNMG 160408 - UL	0.8	0.10~0.30	1.0~3.0		○	●	●	●											
	VNMG160412 - UL	1.2	0.10~0.30	1.5~3.0				●												
-UM 	VNMG 160408 - UM	0.8	0.15~0.30	1.0~3.0		○	○	●	●	●										
	VNMG 160412 - UM	1.2	0.15~0.30	1.5~3.0		○	○	○	●	●										
-UG 	VNMG 160404 - UG	0.4	0.20~0.40	0.5~3.0		●	○	○	●	●	●									
	VNMG 160408 - UG	0.8	0.20~0.40	1.0~3.0		●	○	○	●	●	●	○								
	VNMG 160412 - UG	1.2	0.20~0.40	1.5~3.0		●	○	○	●	●	●									
-UC 	VNMG 160404 - UC	0.4	0.20~0.40	0.5~3.5		●	○	○	●	●	●									
	VNMG 160408 - UC	0.8	0.20~0.40	1.0~3.5		●	○	○	●	●	●									
	VNMG 160412 - UC	1.2	0.20~0.40	1.5~3.5		●	○	○	●	●	●									
-UR 	VNMG 160412 - UR	1.2	0.30~0.50	1.5~5.0		●	○	○	○	●	●	●	○							

Turning - Holder - External
External Holders Overview

Click/Touch each page number and move to the very page!

Series	Turning Holder				
CCGT CCMT	SCACR/L Screw	SCLCR/L Screw			
Page 57	86	86			
CNMA CNMG	PCBNR/L Lever	PCLNR/L Lever (+Clamp)	TCLNR/L Double Clamp	TCBNR/L Double Clamp	TCKNR/L Double Clamp
Page 30	72	72	77	77	77
DCGT DCMT	SDNCN Screw	SDJCR/L Screw	SDHCR/L Screw		
Page 59	87	87	87		
DNMA DNMG	PDNNI Lever (+Clamp)	PDJNR/L Lever (+Clamp)	TDHNR/L Double Clamp	TDNNN Double Clamp	TDJNR/L Double Clamp
Page 35	73	73	78	78	78
KNUX	CKJNR/L Top Clamp				
Page 41	79				
RCMT	SRGCR/L Screw	SRDCN Screw	SRDCN Screw	SRHCN Screw	
Page 61	88	88	88	88	
SCGT SCMT	SSDCN Screw	SSSCR/L Screw			
Page 63	89	89			











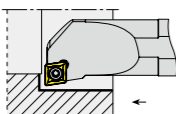
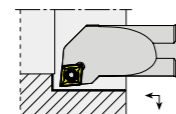
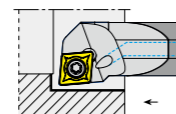

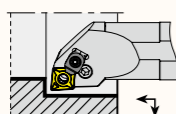
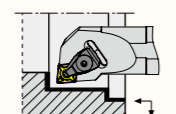
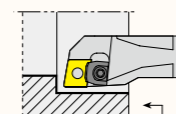
Turning - Holder - External
External Holders Overview

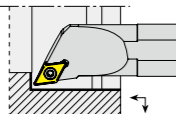
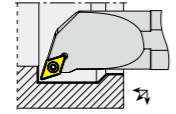
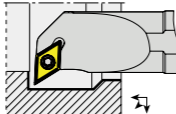
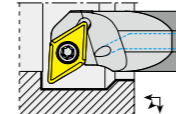
Click/Touch each page number and move to the very page!

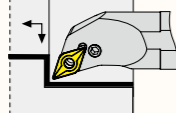
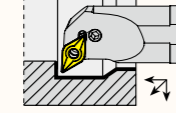
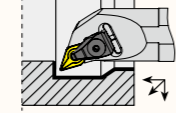
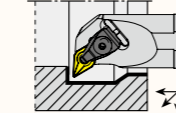
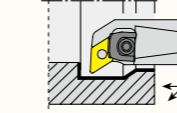
Series	Turning Holder						
SNMA SNMG	PSDNN Lever (+Clamp)	PSSNR/L Lever (+Clamp)	PSBNR/L Lever (+Clamp)	PSKNR/L Lever (+Clamp)	TSDNN Double Clamp	TSSNR/L Double Clamp	TSKNR/L Double Clamp
Page 42	74	74	74	74	80	80	80
TCGT TCMT	STFCR/L Screw	STGCR/L Screw	STJCR/L Screw	STUCR/L Screw			
Page 64	p. 90	p. 90	p. 90	p. 90			
TNMA TNMG TNUX	PTTNR/L Lever (+Clamp)	PTFNR/L Lever (+Clamp)	PTGNR/L Lever (+Clamp)	PTJNR/L Lever (+Clamp)	TTGNR/L Double Clamp	TTJNR/L Double Clamp	MTJNR/L Multi-Clamp
Page 47	75	75	75	75	81	81	84
VBMT	SVHBR/L Screw	SVVBN Screw	SVJBR/L Screw				
Page 66	91	91	91				
VCGT VCMT	SVHCR/L Screw	SVVCN Screw	SVJCR/L Screw				
Page 67	92	92	92				
VNMA VNMG	TVVNN Double Clamp	TVJNR/L Double Clamp	TVHNR/L Double Clamp				
Page 51	82	82	82				
WNMA WNMG	PWLNR/L Lever (+Clamp)	TWLNR/L Double Clamp	MWLNR/L Multi-Clamp				
Page 53	76	83	85				

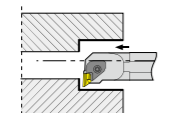

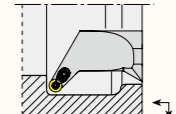

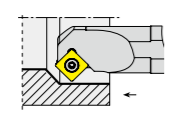





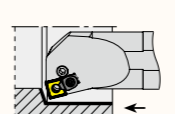
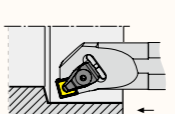

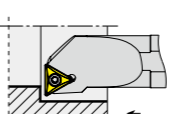
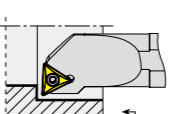
Turning - Holder - Internal
Internal Holders Overview

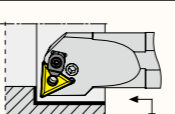
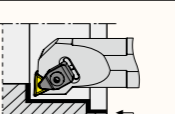
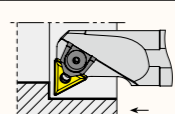
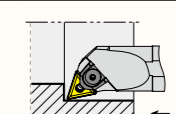
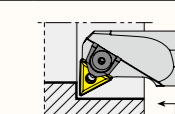
Click/Touch each page number and move to the very page!

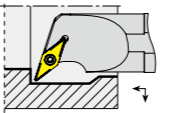
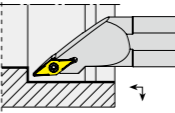
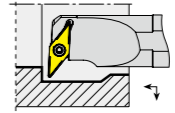
Series	Turning Holder				
 CCGT CCMT					
	..SFCR/L	..SCLCR/L	E..SCLCR/L		
	Screw	Screw	Screw		
Page	57	108	109	109	
 CNMA CNMG					
	..PCLNR/L	..TCLNR/L	..MCLNR/L		
	Lever (+Clamp)	Double Clamp	Multi-Clamp		
Page	30	93	98	104	
 DCGT DCMT					
	..SDPCR/L	..SDQCR/L	..SDUCR/L	E..SDUCR/L	
	Screw	Screw	Screw	Screw	
Page	59	110	110	111	
 DNMA DNMG					
	..PDQNR/L	..PDUNR/L	..TDQNR/L	..TDUNR/L	..MDUNR/L
	Lever (+Clamp)	Lever (+Clamp)	Double Clamp	Double Clamp	Multi-Clamp
Page	35	94	94	99	104
 KNUX					
	..CKUNR/L				
	Top Clamp				
Page	41	107			
 RCMT					
	..SRGCR-L				
	Screw Type				
Page	61	112			
 SCGT SCMT					
	..SSSCR/L				
	Screw Type				
Page	63	113			

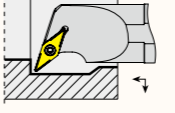
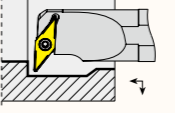
Turning - Holder - Internal
Internal Holders Overview

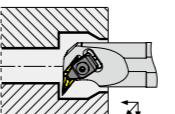
Click/Touch each page number and move to the very page!

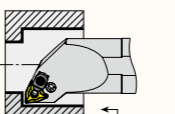
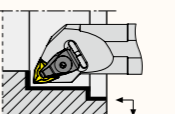
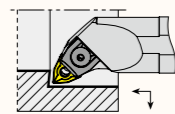
Series	Turning Holder				
 SNMA SNMG					
	..PSKNR/L	..TSKNR/L			
	Lever (+Clamp)	Double Clamp			
Page	42	95	100		
 TCGT TCMT					
	..STFCR/L	..STUCR/L			
	Screw	Screw			
Page	64	114	114		
 TNMA TNMG TNUX					
	..PTUNR/L	..TTUNR/L	..MTFNR/L	..MTQNR/L	..MTUNR/L
	Lever (+Clamp)	Double Clamp	Pin + Clamp	Multi-Clamp	Pin + Clamp
Page	47	96	101	105	105
 VBMT					
	..SVQBR/L	..SVJBR/L	..SVUBR/L		
	Screw	Screw	Screw		
Page	66	115	115	115	
 VCGT VCMT					
	..SVQCR/L	..SVUCR/L			
	Screw	Screw			
Page	67	116	116		
 VNMA VNMG					
	..TVUNR/L				
	Double Clamp				
Page	51	102			
 WNMA WNMG					
	..PWLNR/L	..TWLNR/L	..MWLNR/L		
	Lever (+Clamp)	Double Clamp	Multi-Clamp		
Page	53	97	103	106	

Turning - Holder - External Lever Lock type for CN** Insert

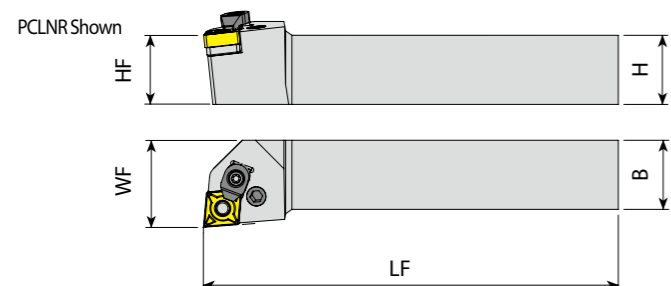

* 'C' Letter at Last : Optional Clamp Included

: p. 30 Unit:mm

Series	Designation	EDP 2700.. R	EDP 2700.. L	H (= HF)	B	WF	LF	Insert
 PCBNR/L Approach angle 75°	PCBNR/L 2020K 12C	0438	0439	20	20	17.5	125	CN1204
	PCBNR/L 2525M 12C	0440	0441	25	25	22.5	150	
	PCBNR/L 3232P 12C	0442	0443	32	32	29.5	170	
	CN1606	PCBNR/L 2525M 16C	0444	0445	25	25	22.0	150
		PCBNR/L 3232P 16C	0446	0447	32	32	27.0	170
		PCBNR/L 3232P 19C	0448	0449	32	32	37.0	170
	CN1906	PCBNR/L 4040S 19C	0450	0451	40	40	37.0	250
 PCLNR/L Approach angle 95°	PCLNR/L 1616-H09	0001	0002	16	16	20.0	100	CN0903
	PCLNR/L 1616H 12	0464	0465	16	16	20.0	100	CN1204
	PCLNR/L 2020K 12C	0466	0467	20	20	25.0	125	
	PCLNR/L 2525M 12C	0468	0469	25	25	32.0	150	
	CN1606	PCLNR/L 3232P 12C	0470	0471	32	32	40.0	170
		PCLNR/L 2525M 16C	0472	0473	25	25	32.0	150
	CN1906	PCLNR/L 3232P 16C	0474	0475	32	32	40.0	170
		PCLNR/L 2525M 19C	0476	0477	25	25	32.0	150
	CN1906	PCLNR/L 3232P 19C	0478	0479	32	32	40.0	170
		PCLNR/L 4040S 19C	0480	0481	40	40	50.0	250

Series	Designation	Information	Lever	Lever Screw	Clamp	Clamp Screw	Shim	Shim Pin	Allen Key
H09	Description	YAPL-01	YALV-02-M6x17	-	-	YAACN-2-0002	YAAY-01	YAAL-02-2.5	
	EDP	18000092	18000099	-	-	28000028	18000053	18000060	
..12	Description	YAPL-02	YALV-03-M8x19	-	-	YAACN-3-0001	YAAY-02	YAAL-03-3	
	EDP	18000093	18000100	-	-	18000137	18000054	18000061	
PC.. ..12C	Description	YAPL-02	YALV-03-M8x19	YACK-05	Y4015-M4x11	YAACN-3-0001	YAAY-02	YAAL-03-3	
	EDP	18000093	18000100	18000065	18000119	18000137	18000054	18000061	
..16C	Description	YAPL-04	YALV-04-M8x22	YACK-09	YAAV-05-M6x15	YAACN-3-0002	YAAY-03	YAAL-03-3	
	EDP	18000095	18000101	18000066	18000078	18000138	18000055	18000061	
..19C	Description	YAPL-05	YALV-05-M10x27	YACK-09	YAAV-05-M6x15	YAACN-3-0003	YAAY-04	YAAL-05-4	
	EDP	18000096	18000102	18000066	18000078	18000139	18000056	18000062	

Turning - Holder - External Lever Lock type for DN** Insert

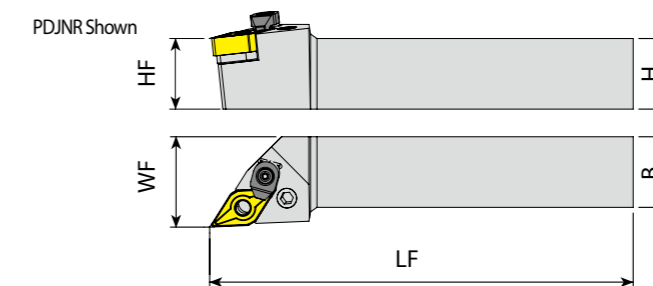

* 'C' Letter at Last : Optional Clamp Included

: p. 35 Unit:mm

Series	Designation	EDP 2700.. R	EDP 2700.. L	H (= HF)	B	WF	LF	Insert
 PDNNN Approach angle 62.5°	PDNNN 2020K 15C	0515		20	20	10.0	125	DN1506
	PDNNN 2525M 15C	0516		25	25	12.5	150	
	PDNNN 3232P 15C	0517		32	32	16.0	170	
 PDJNR/L Approach angle 93°	PDJNR/L 1616-H11	0031	0032	16	16	20.0	100	DN1104
	PDJNR/L 2020K 15C	0500	0501	20	20	25.0	125	DN1506
	PDJNR/L 2525M 15C	0502	0503	25	25	32.0	150	
	PDJNR/L 3232P 15C	0504	0505	32	32	40.0	170	
	PDJNR/L 4040S 15C	1734	0506	40	40	50.0	250	

Series	Designation	Information	Lever	Lever Screw	Clamp	Clamp Screw	Shim	Shim Pin	Allen Key
..15C	Description	YAPL-03	YALV-03-M8x19	YACK-05	Y4015-M4x11	YAADN-3-0001	YAAY-02	YAAL-03-3	
	EDP	18000094	18000100	18000065	18000119	18000137	18000054	18000061	
PD.. ..H11	Description	YAPL-01	YALV-02-M6x17	-	-	YAADN-SD317	YAAY-01	YAAL-02-2.5	
	EDP	18000092	18000099	-	-	28000029	18000053	18000060	
..M15	Description	YAPL-03	YALV-03-M8x19	YACK-05	Y4015-M4x11	YAADN-3-0001	YAAY-02	YAAL-03-3	
	EDP	18000094	18000100	18000065	18000119	18000137	18000054	18000061	

Lever Lock type for SN Insert**

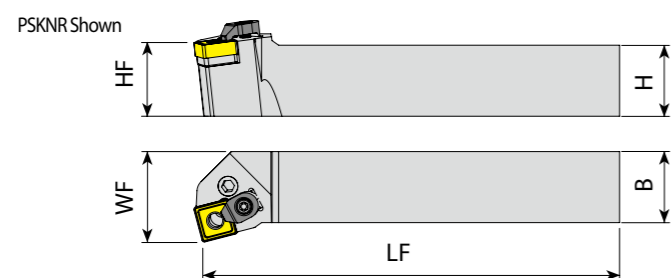

* 'C' Letter at Last : Optional Clamp Included

: p. 42

Unit:mm

Series	Designation	EDP 2700.. R L	H (= HF)	B	WF	LF	Insert
 PSDNN Approach angle 45°	PSDNN 1616-H09	0075	16	16	8.0	100	SN0903
	PSDNN 2020K 12C	0530	20	20	10.0	125	SN1204
	PSDNN 2525M 12C	0531	25	25	12.5	150	
	PSDNN 3232P 12C	0532	32	32	16.0	170	
 PSSNR/L Approach angle 45°	PSSNR/L 1616-H09	0079 0080	16	16	20.0	100	SN0903
	PSSNR/L 2020K 12C	0548 0549	20	20	25.0	125	SN1204
	PSSNR/L 2525M 12C	0550 0551	25	25	32.0	150	
	PSSNR/L 3232P 12C	0552 0553	32	32	40.0	170	
 PSBNR/L Approach angle 75°	PSBNR/L 1616-H09	0069 0070	16	16	13.0	100	SN0903
	PSBNR/L 2020K 12	0430 0525	20	20	17.0	125	SN1204
	PSBNR/L 2525M 12C	0526 0527	25	25	22.0	150	
	PSBNR/L 3232P 12C	0528 0529	32	32	27.0	170	SN1204
 PSKNR/L Approach angle 75°	PSKNR/L 2020K 12C	0537	20	20	25.0	125	SN1204
	PSKNR/L 2525M 12C	0538 0539	25	25	32.0	150	
	PSKNR/L 3232P 12C	0540 0541	32	32	40.0	170	

Series	Designation	Infomation	Lever	Lever Screw	Clamp	Clamp Screw	Shim	Shim Pin	Allen Key
PS..	..H09	Description	YAPL-01	YALV-02-M6x17	-	-	YAASN-2-0002	YAAY-01	YAAL-02-2.5
		EDP	18000092	18000099			28000028	18000053	18000060
	..12	Description	YAPL-02	YALV-03-M8x19	-	-	YAASN-3-0004	YAAY-02	YAAL-03-3
		EDP	18000093	18000100			18000145	18000054	18000060
	..12C	Description	YAPL-02	YALV-03-M8x19	YACK-05	Y4015-M4x11	YAASN-3-0004	YAAY-02	YAAL-03-3
		EDP	18000093	18000100	18000065	18000119	18000145	18000054	18000060

Lever Lock type for TN Insert**

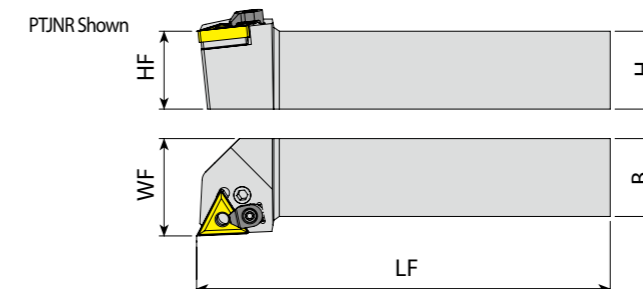

* 'C' Letter at Last : Optional Clamp Included

: p. 47

Unit:mm

Series	Designation	EDP 2700.. R L	H (= HF)	B	WF	LF	Insert	
 PTTNR/L Approach angle 60°	PTTNR/L 1616H 16	0619 0620	16	16	13.0	100	TN1604	
	PTTNR/L 2020K 16	0429 0621	20	20	17.0	125		
	PTTNR/L 2525M 16	0622 0623	25	25	21.5	150		
	 PTTNR/L Approach angle 60°	PTTNR/L 3232P 16	0624 0625	32	32	31.0	170	TN2204
		PTTNR/L 2525M 22C	0626 0627	25	25	20.5	150	
		PTTNR/L 3232P 22C	0628 0629	32	32	29.0	170	
 PTFNR/L Approach angle 91°	PTFNR/L 1616H 16	0560 0561	16	16	20.0	100	TN1604	
	PTFNR/L 2020K 16	0049 0050	20	20	25.0	125		
	PTFNR/L 2525M 16	0051 0052	25	25	32.0	150		
	 PTFNR/L Approach angle 91°	PTFNR/L 3232P 16	0562 0563	32	32	40.0	170	TN2204
		PTFNR/L2525M 22C	0564 0565	25	25	32.0	150	
		PTFNR/L 3232P 22C	0566 0567	32	32	40.0	170	
 PTGNR/L Approach angle 91°	PTGNR/L 1616H 16	0568 0569	16	16	20.0	100	TN1604	
	PTGNR/L 2020K 16	0055 0056	20	20	25.0	125		
	PTGNR/L 2525M 16	0057 0058	25	25	32.0	150		
	 PTGNR/L Approach angle 91°	PTGNR/L 2525M 22C	0570 0571	25	25	32.0	150	TN2204
		PTGNR/L 3232P 22C	0572 0573	32	32	40.0	170	
		PTJNR/L 1616H 16	0597 0598	16	16	20.0	100	
PTJNR/L 2020K 16	0599 0600	20	20	25.0	125			
PTJNR/L 2525M 16	0601 0602	25	25	32.0	150			
PTJNR/L 3232P 16	0603 0604	32	32	40.0	170			
PTJNR/L 2525M 22C	0605 0606	25	25	32.0	150			
PTJNR/L 3232P 22C	0607 0608	32	32	40.0	170	TN2204		

Series	Designation	Infomation	Lever	Lever Screw	Clamp	Clamp Screw	Shim	Shim Pin	Allen Key
PT..	..16	Description	YAPL-01	YALV-02-M6x17	-	-	YAATN-3-0025	YAAY-01	YAAL-02-2.5
		EDP	18000092	18000099			18000149	18000053	18000060
	..22..	Description	YAPL-02	YALV-03-M8x19	YACK-05	Y4015-M4x11	YAATN-3-0015	YAAY-02	YAAL-03-3
		EDP	18000093	18000100	18000065	18000119	18000148	18000054	18000061

Lever Lock type for WN** Insert

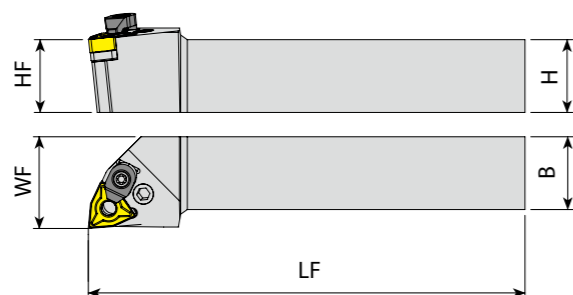

*'C' Letter at Last : Optional Clamp Included

□ : p. 53 Unit:mm

Series	Designation	EDP 2700..		H (= HF)	B	WF	LF	Insert
		R	L					
PWLNR/L Approach angle 95°	PWLNR/L 1616H 06	0647	0648	16	16	20	100	WN0604
	PWLNR/L 2020K 06	0649	0650	20	20	25	125	
	PWLNR/L 2525M 06	0651	0652	25	25	32	150	
	PWLNR/L 1616H 08	0653	0654	16	16	20	100	
	PWLNR/L 2020K 08C	0655	0656	20	20	25	125	WN0804
	PWLNR/L 2525M 08C	0657	0658	25	25	32	150	
	PWLNR/L 3232P 08C	0659	0660	32	32	40	170	

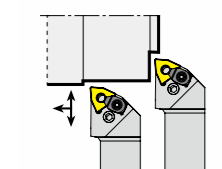

Double Clamp type for CN** Insert

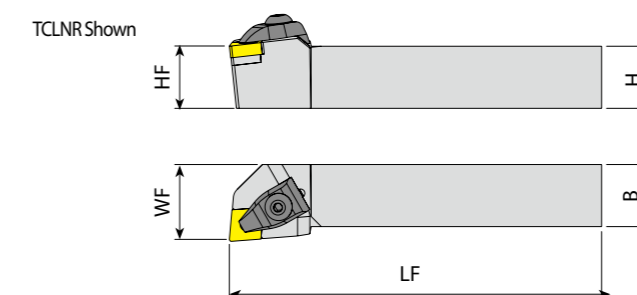

□ : p. 30 Unit:mm

Series	Designation	EDP 2700..		H (= HF)	B	WF	LF	Insert
		R	L					
TCLNR/L Approach angle 95°	TCLNR/L 2020K 12	0482	0483	20	20	25	125	CN1204
	TCLNR/L 2525M 12	0484	0485	25	25	32	150	
	TCLNR/L 3232P 12	0486	0487	32	32	40	170	
	TCLNR/L 4040S 12	0488	0489	40	40	50	250	
	TCLNR/L 5050S 12	0490	0491	50	50	63	250	CN1606
	TCLNR/L 2525M 16	0492	0493	25	25	32	150	
	TCLNR/L 3232P 16	0494	-	32	32	40	170	
	TCLNR/L 2525M 16	0452	0453	25	25	22	150	
TCKNR/L Approach angle 75°	TCKNR/L 2020K 12	0454	0455	20	20	25	125	CN1204
	TCKNR/L 2525M 12	0456	0457	25	25	32	150	
	TCKNR/L 3232P 12	0458	0459	32	32	40	170	
	TCKNR/L 2525M 16	0460	0461	25	25	32	150	CN1606
	TCKNR/L 3232P 16	0462	0463	32	32	40	170	

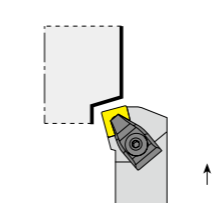
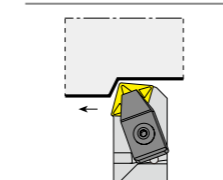
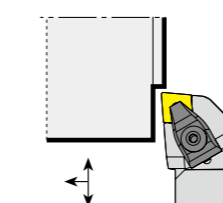

Series	Designation	Infomation	Lever	Lever Screw	Clamp	Clamp Screw	Shim	Shim Pin	Allen Key
PW..	..06	Description	YAPL-01	YALV-02-M6x17	-	-	YAAWN-SW317	YAAY-01	YAAL-02-2.5
		EDP	18000092	18000099	-	-	18000152	18000053	18000060
	..08	Description	YAPL-02	YALV-03-M8x19	-	-	YAAWN-3-0001	YAAY-02	YAAL-03-3
		EDP	18000093	18000100	-	-	18000151	18000054	18000061
	..08C	Description	YAPL-02	YALV-03-M8x19	YACK-05	Y4015-M4x11	YAAWN-3-0001	YAAY-02	YAAL-03-3
		EDP	18000093	18000100	18000065	18000119	18000151	18000054	18000061

Series	Designation	Infomation	Clamp	Clamp Screw	Upper Ring	Lower Ring	Shim	Shim Screw	Allen Key
TC..	..12	Description	YATK-02	YAKV-30-M6x22	YABPL-01	YAS-01	YAACN-3-0001	YAAV-02-M5x12	YAAL-03-3
		EDP	18000075	18000091	18000058	18000052	18000137	18000156	18000061
	..16	Description	YATK-04	YAKV-19-M7x25	YABPL-02	YAS-02	YAACN-3-0002	YAAV-05-M6x15	YAAL-05-4
		EDP	18000077	18000088	18000059	28000042	18000138	18000078	18000062

Double Clamp type for DN Insert**

TDJNR Shown

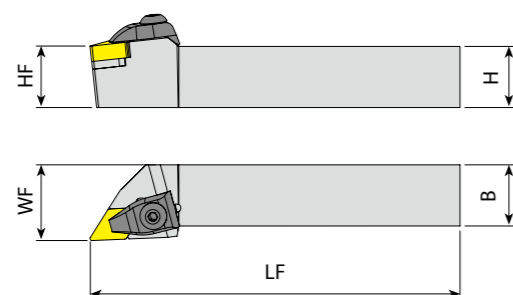

☐ : p.35 Unit:mm

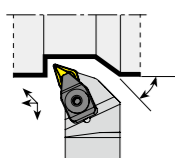
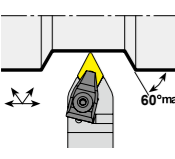
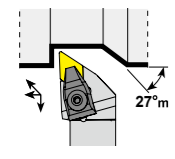
Series	Designation	EDP 2700..		H (= HF)	B	WF	LF	Insert
		R	L					
 <p>TDHNR/L Approach angle 107.5°</p>	TDHNR/L 2020K 15	0495	0496	20	20	25.0	125	DN1506
	TDHNR/L 2525M 15	0497	0498	25	25	32.0	150	
	TDHNR/L 3232P 15	0499	-	32	32	40.0	170	
 <p>TDNNN Approach angle 62.5°</p>	TDNNN 2020K 15	0518		20	20	10.0	125	DN1506
	TDNNN 2525M 15	0519		25	25	12.5	150	
	TDNNN 3232P 15	0520		32	32	16.0	170	
 <p>TDJNR/L Approach angle 93°</p>	TDJNR/L 2020K 15	0507	0508	20	20	25.0	125	DN1506
	TDJNR/L 2525M 15	0509	0510	25	25	32.0	150	
	TDJNR/L 3232P 15	0511	0512	32	32	40.0	170	
	TDJNR/L 4040S 15	0513	0514	40	40	50.0	250	

Series	Designation	Infomation	Clamp	Clamp Screw	Upper Ring	Lower Ring	Shim	Shim Screw	Allen Key
TD..	..15	Description	YATK-02	YAKV-30-M6x22	YABPL-01	YAS-01	YAADN-3-0001	YAAV-02-M5x12	YAAL-03-3
		EDP	18000075	18000091	18000058	18000052	18000142	18000156	18000061

Top Clamp type for KN Insert**

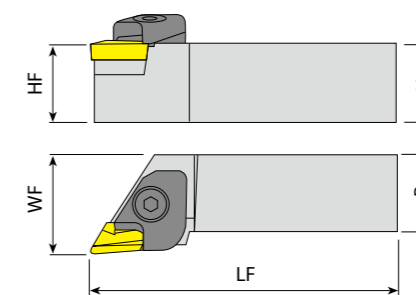

☐ : p.41 Unit:mm

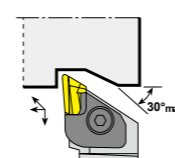
Series	Designation	EDP 2700..		H (= HF)	B	WF	LF	Insert
		R	L					
 <p>CKJNR/L Approach angle 93°</p>	CKJNR/L 2020K 16	0521	0522	20	20	27.5	125	KNUX1604
	CKJNR/L 2525M 16	0152	0153	25	25	31.5	150	
	CKJNR/L 3232P 16	0154	0155	32	32	40.0	170	
	CKJNR/L 4040S 16	0523	0524	40	40	50.0	250	

Series	Designation	Infomation	Clamp	Clamp Screw	Spring	Upper Ring	Shim	Shim Screw	Allen Key
CK..	..16	Description	YACK-01-R	YAKV-06-M6x20	YAKY-02	YABPL-01	YAKS-16-R	YAAV-01-M3x10	YAAL-05-4
		EDP	18000064	18000083	18000164	18000058	18000154	18000155	18000062
	..16	Description	YACK-02-L	YAKV-06-M6x20	YAKY-02	YABPL-01	YAKS-16-L	YAAV-01-M3x10	YAAL-05-4
		EDP	18000063	18000083	18000164	18000058	18000153	18000155	18000062

Turning - Holder - External

Double Clamp type for SN** Insert

TSSNR Shown

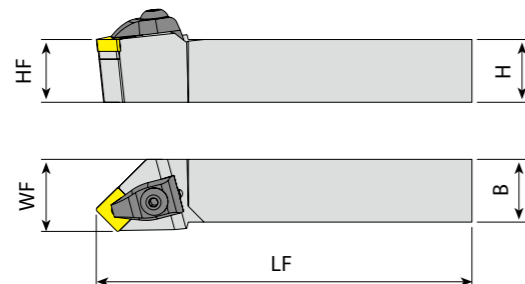

□ : p.42 Unit:mm

Series	Designation	EDP 2700.. R L	H (= HF)	B	WF	LF	Insert
<p>TSDNN Approach angle 45°</p>	TSDNN 1616H 12	0533	16	16	8.0	100	SN1204
	TSDNN 2020K 12	0534	20	20	10.0	125	
	TSDNN 2525M 12	0535	25	25	12.5	150	
	TSDNN 3232P 12	0536	32	32	16.0	170	
<p>TSSNR/L Approach angle 45°</p>	TSSNR/L 2020K 12	0554 0555	20	20	25.0	125	SN1204
	TSSNR/L 2525M 12	0556 0557	25	25	32.0	150	
	TSSNR/L 3232P 12	0558 0559	32	32	40.0	170	
<p>TSKNR/L Approach angle 75°</p>	TSKNR/L 2020K 12	0542 0543	20	20	25.0	125	SN1204
	TSKNR/L 2525M 12	0544 0545	25	25	32.0	150	
	TSKNR/L 3232P 12	0546 0547	32	32	40.0	170	

Series	Designation	Infomation	Clamp	Clamp Screw	Upper Ring	Lower Ring	Shim	Shim Screw	Allen Key
TS..	..12	Description	YATK-02	YAKV-30-M6x22	YABPL-01	YAS-01	YAASN-3-0004	YAAV-02-M5x12	YAAL-03-3
		EDP	18000075	18000091	18000058	18000052	18000145	18000156	18000061

Turning - Holder - External

Double Clamp type for TN** Insert

TTJNR Shown

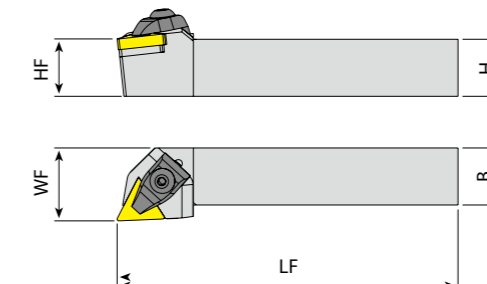

□ : p.47 Unit:mm

Series	Designation	EDP 2700.. R L	H (= HF)	B	WF	LF	Insert	
<p>TTGNR/L Approach angle 91°</p>	TTGNR/L 2020K 16	0574 0575	20	20	25	125	TN1604	
	TTGNR/L 2525M 16	0576 0577	25	25	32	150		
	TTGNR/L 3232P 16	0578 0579	32	32	40	170		
	<p>TTJNR/L Approach angle 93°</p>	TTGNR/L 2525M 22	0580 0581	25	25	32	150	TN2204
		TTGNR/L 3232P 22	0582 0583	32	32	40	170	
		TTGNR/L 4040S 22	0584 -	40	40	50	250	
<p>TTJNR/L Approach angle 93°</p>	TTJNR/L 2020K 16	0609 0610	20	20	25	125	TN1604	
	TTJNR/L 2525M 16	0611 0612	25	25	32	150		
	TTJNR/L 3232P 16	0613 0614	32	32	40	170	TN2204	
	TTJNR/L 2525M 22	0615 0616	25	25	32	150		
	TTJNR/L 3232P 22	0617 0618	32	32	40	170		

Series	Designation	Infomation	Clamp	Clamp Screw	Upper Ring	Lower Ring	Shim	Shim Screw	Allen Key
TT..	..16	Description	YATK-01	YAKV-01-M5x22	YABPL-01	-	YAATN-2-0002	YAAV-03-M5x12	YAAL-03-3
		EDP	18000074	18000080	18000058	-	18000147	18000157	18000061
	..22	Description	YATK-02	YAKV-30-M6x22	YABPL-01	YAS-01	YAATN-3-0015	YAAV-02-M5x12	YAAL-03-3
		EDP	18000075	18000091	18000058	18000052	18000148	18000156	18000061

Turning - Holder - External

Double Clamp type for VN** Insert

TVJNRShown

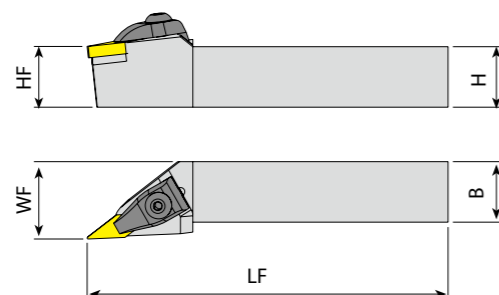

□: p. 51 Unit:mm

Series	Designation	EDP 2700.. R L	H (= HF)	B	WF	LF	Insert
<p>TVVNN Approach angle 72.5°</p>	TVVNN 2020K 16	0642	20	20	10.0	125	VN1604
	TVVNN 2525M 16	0643	25	25	12.5	150	
	TVVNN 3232P 16	0644	32	32	16.0	170	
<p>TVJNR/L Approach angle 93°</p>	TVJNR/L 2020K 16	0636 0637	20	20	25.0	125	VN1604
	TVJNR/L 2525M 16	0638 0639	25	25	32.0	150	
	TVJNR/L 3232P 16	0640 0641	32	32	40.0	170	
<p>TVHNR/L Approach angle 107.5°</p>	TVHNR/L 2020K 16	0630 0631	20	20	25.0	125	VN1604
	TVHNR/L 2525M 16	0632 0633	25	25	32.0	150	
	TVHNR/L 3232P 16	0634 0635	32	32	40.0	170	

Series	Designation	Infomation	Clamp	Clamp Screw	Upper Ring	Lower Ring	Shim	Shim Screw	Allen Key
TV..	..16	Description	YATK-03	YAKV-30-M6x22	YABPL-01	YAS-01	YAAVN -2-0002	YAAV-04-M5x12	YAAL-03-3
		EDP	18000076	18000091	18000058	18000052	18000150	18000158	18000061

Turning - Holder - External

Double Clamp type for WN** Insert

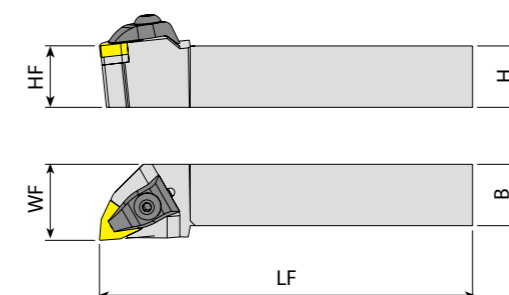

□: p. 53 Unit:mm

Series	Designation	EDP 2700.. R L	H (= HF)	B	WF	LF	Insert
<p>TWLNR/L Approach angle 95°</p>	TWLNR/L 1616H 06	0661 0662	16	16	20	100	WN0604
	TWLNR/L 2020K 06	0663 0664	20	20	25	125	
	TWLNR/L 2525M 06	0665 0666	25	25	32	150	
	TWLNR/L 2020K 08	0667 0668	20	20	25	125	WN0804
	TWLNR/L 2525M 08	0669 0670	25	25	32	150	
	TWLNR/L 3232P 08	0671 0672	32	32	40	170	
TWLNR/L 4040S 08	0673 0674	40	40	50	250		

Series	Designation	Infomation	Clamp	Clamp Screw	Upper Ring	Lower Ring	Shim	Shim Screw	Allen Key
TW..	..06	Description	YATK-01	YAKV-01-M5x22	YABPL-01	-	YAAWN-SW317	YAAV-01-M3x10	YAAL-03-3
		EDP	18000074	18000080	18000058	-	18000152	18000155	18000061
	..08	Description	YATK-02	YAKV-30-M6x22	YABPL-01	YAS-01	YAAWN-3-0001	YAAV-02-M5x12	YAAL-03-3
		EDP	18000075	18000091	18000058	18000052	18000151	18000156	18000061

Turning - Holder - External

Multi-Clamp type for TN** Insert

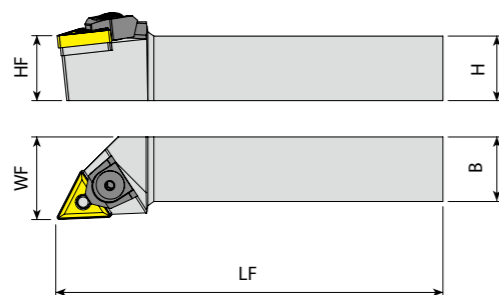

□ : p.47 Unit:mm

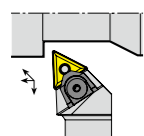
Series	Designation	EDP 2700..		H (= HF)	B	WF	LF	Insert
		R	L					
 MTJNR/L Approach angle 93°	MTJNR/L 2020K 16	0585	0586	20	20	25	125	TN1604
	MTJNR/L 2525M 16	0587	0588	25	25	32	150	
	MTJNR/L 3232P 16	0589	0590	32	32	40	170	
	MTJNR/L 2525M 22	0591	0592	25	25	32	150	TN2204
	MTJNR/L 3232P 22	0593	0594	32	32	40	170	
	MTJNR/L 4040S 22	0595	0596	40	40	50	250	

Turning - Holder - External

Multi-Clamp type for WN** Insert

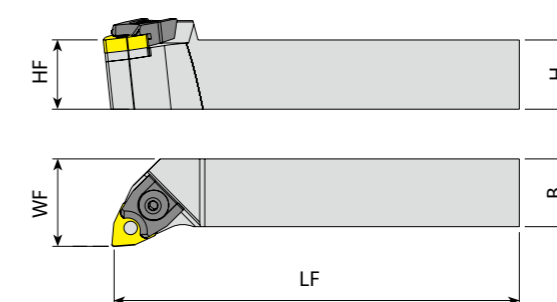

□ : p.53 Unit:mm

Series	Designation	EDP 2700..		H (= HF)	B	WF	LF	Insert
		R	L					
 MWLNR/L Approach angle 95°	MWLNR/L 1616H 06	0645	0646	16	16	20	100	WN0604
	MWLNR/L 2020K 06	0021	0022	20	20	25	125	
	MWLNR/L 2525M 06	0023	0024	25	25	32	150	
	MWLNR/L 2020K 08	0025	0026	20	20	25	125	WN0804
	MWLNR/L 2525M 08	0027	0028	25	25	32	150	
	MWLNR/L 3232P 08	0029	0030	32	32	40	170	

Series	Designation	Information	Clamp	Clamp Screw	Upper Ring	Lower Ring	Pin	Shim	Allen Key
MT..	..16	Description	YAMK-04	YAKV-30-M6x22	YABPL-01	YAS-01	YAPM-01	YAATN-2-0002	YAAL-03-3
		EDP	18000072	18000091	18000058	18000052	18000110	18000147	18000061
	..22	Description	YAMK-04	YAKV-30-M6x22	YABPL-01	YAS-01	YAPM-02	YAATN-3-0015	YAAL-03-3
		EDP	18000072	18000091	18000058	18000052	18000111	18000148	18000061

Series	Designation	Information	Clamp	Clamp Screw	Upper Ring	Lower Ring	Pin	Shim	Allen Key
MW..	..06	Description	YAMK-01	YAKV-04-M5x17	-	-	YAPM-08	-	YAAL-03-3
		EDP	18000070	18000082			18000114		18000061
	..08	Description	YAMK-05	YAKV-03-M6x22	YABPL-01	YAS-01	YAPM-02	YAAWN-3-0001	YAAL-03-3
		EDP	18000073	18000081	18000058	18000052	18000111	18000151	18000061

Turning - Holder - External Screw on type for CC** Insert

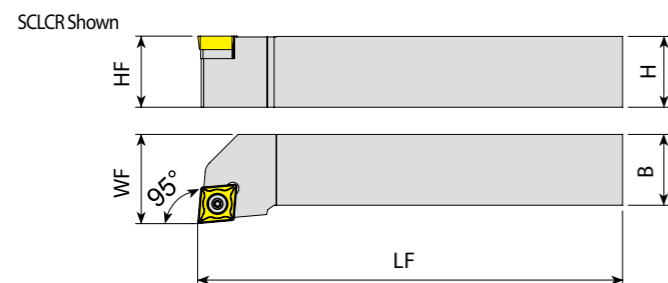

: p. 57 Unit:mm

Series	Designation	EDP 2700.. R	EDP 2700.. L	H (= HF)	B	WF	LF	Insert
 SCACR/L Approach angle 90°	SCACR/L 0808E 06	0675	0676	08	08	10	70	CC0602
	SCACR/L 1010E 06	0677	0678	10	10	12	70	
	SCACR/L 1212F 09	0679	0680	12	12	16	80	CC09T3
	SCACR/L 1616H 09	0681	0682	16	16	20	100	
	SCACR/L 2020K 09	0683	0684	20	20	25	125	
	SCACR/L 2020K 12	0685	0686	20	20	25	125	CC1204
	SCACR/L 2525M 12	0687	0688	25	25	32	150	
 SCLCR/L Approach angle 95°	SCLCR/L 0808E 06	0689	0690	08	08	10	70	CC0602
	SCLCR/L 1010E 06	0691	-	10	10	12	70	
	SCLCR/L 1010E 09	0692	0693	10	10	12	70	CC09T3
	SCLCR/L 1212F 09	0089	0090	12	12	16	80	
	SCLCR/L 1616H 09	0091	0092	16	16	20	100	
	SCLCR/L 2020K 09	0093	0094	20	20	25	125	CC1204
	SCLCR/L 2525M 09	0694	0695	25	25	32	150	
	SCLCR/L 1616H 12	0696	-	16	16	20	100	
	SCLCR/L 2020K 12	0095	0096	20	20	25	125	
	SCLCR/L 2525M 12	0097	0098	25	25	32	150	

Series	Designation	Infomation	Screw	Shim	Shim Screw	Torx Key
SC..	..06	Description	Y4008-M2.5x6	-	-	Y80-T08
		EDP	18000127	-	-	18000165
	..F09	Description	Y4015-M3.5x11	YAACN-2-0001	YAAV-06-M3.5x11	Y80-T15
		EDP	18000118	18000135	18000159	18000167
	..H09	Description	Y4015-M3.5x14	YAACN-2-0001	YAAV-06-M3.5x11	Y80-T15
		EDP	18000129	18000135	18000159	18000167
	..12	Description	Y1020-M4.5x16	YAACN-2-0003	YAAV-07-M4.5x13	Y80-T20
		EDP	18000120	18000136	18000160	18000168
	..1010..09	Description	Y4015-M3x9	-	-	Y80-T15
		EDP	18000132	-	-	18000159
	..1212..09	Description	Y4015-M3.5x11	-	-	Y80-T15
		EDP	18000118	-	-	18000159
	..1616~2525..09	Description	Y4015-M3.5x14	YAACN-2-0001	YAAV-06-M3.5x11	Y80-T15
		EDP	18000129	18000135	18000159	18000159
	..1616..12	Description	Y1020-M5x11	-	-	Y80-T20
		EDP	18000121	-	-	18000168
	..2020~2525..12	Description	Y1020-M4.5x16	YAACN-2-0003	YAAV-07-M4.5x13	Y80-T20
		EDP	18000120	18000136	18000160	18000168

Turning - Holder - External Screw on type for DC** Insert

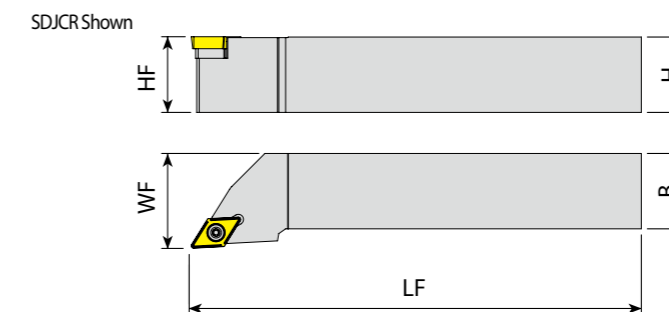

: p. 59 Unit:mm

Series	Designation	EDP 2700.. R	EDP 2700.. L	H (= HF)	B	WF	LF	Insert
 SDNCN Approach angle 62.5°	SDNCN 0808E 07	0723		08	08	4.0	70	DC0702
	SDNCN 1010E 07	0724		10	10	5.0	70	
	SDNCN 1212F 07	0123		12	12	6.0	80	
	SDNCN 1616H 07	0725		16	16	8.0	100	DC11T3
	SDNCN 1616H 11	0124		16	16	8.0	100	
	SDNCN 2020K 11	0125		20	20	10.0	125	
	SDNCN 2525M 11	0126		25	25	12.5	150	
	SDNCN 3232P 11	0726		32	32	16.0	170	
 SDJCR/L Approach angle 93°	SDJCR/L 0808E 07	0713	0714	08	08	10.0	70	DC0702
	SDJCR/L 1010E 07	0715	0716	10	10	12.0	70	
	SDJCR/L 1212F 07	0113	0114	12	12	16.0	80	DC11T3
	SDJCR/L 1616H 07	0717	0718	16	16	20.0	100	
	SDJCR/L 1616H 11	0117	0118	16	16	20.0	100	
	SDJCR/L 2020K 11	0119	0120	20	20	25.0	125	
	SDJCR/L 2525M 11	0719	0720	25	25	32.0	150	
	SDJCR/L 3232P 11	0721	0722	32	32	40.0	170	
 SDHCR/L Approach angle 107.5°	SDHCR/L 0808E 07	0697	0698	05	05	11.0	70	DC0702
	SDHCR/L 1010E 07	0699	0700	10	10	12.0	70	
	SDHCR/L 1212F 07	0701	0702	12	12	16.0	80	DC11T3
	SDHCR/L 1616H 07	0703	0704	16	16	20.0	100	
	SDHCR/L 1616H 11	0705	0706	16	16	20.0	100	
	SDHCR/L 2020K 11	0707	0708	20	20	25.0	125	
	SDHCR/L 2525M 11	0709	0710	25	25	32.0	150	
	SDHCR/L 3232P 11	0711	0712	32	32	40.0	170	

Series	Designation	Infomation	Screw	Shim	Shim Screw	Torx Key
SD..	..07	Description	Y4008-M2.5x6	-	-	Y80-T08
		EDP	8000127	-	-	18000165
	..11	Description	Y4015-M3.5x14	YAADN-2-0001	YAAV-06-M3.5x11	Y80-T15
		EDP	18000129	18000140	18000159	18000167

Screw on type for RC Insert**

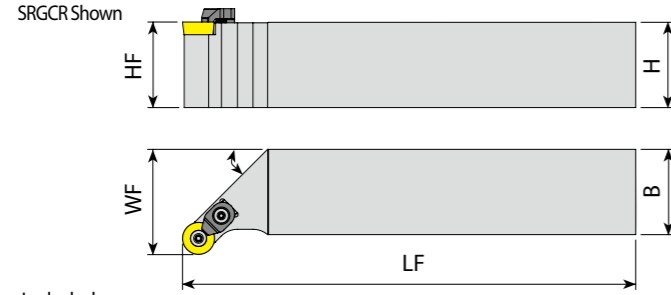

*'C' Letter at Last : Optional Clamp Included

□ : p. 61 Unit: mm

Series	Designation	EDP 2700..		H (= HF)	B	WF	LF	Insert
		R	L					
SRGCR/L Approach angle 90°	SRGCR/L 1616H 06	0739	0740	16	16	20.0	100	RC0602
	SRGCR/L 2020K 06	0741	0742	20	20	25.0	125	
	SRGCR/L 1616H 08C	0743	0744	16	16	32.0	100	RC0803
	SRGCR/L 2020K 08C	0745	0746	20	20	25.0	125	
	SRGCR/L 2525M 08C	0747	0748	25	25	32.0	150	RC10T3
	SRGCR/L 1616H 10C	0749	0750	16	16	20.0	100	
	SRGCR/L 2020K 10C	0751	0752	20	20	25.0	125	RC1204
	SRGCR/L 2525M 10C	0753	0754	25	25	32.0	150	
	SRGCR/L 3232P 10C	0755	0756	32	32	40.0	170	RC1204
	SRGCR/L 2020K 12C	0757	0758	20	20	25.0	125	
SRDCN Approach angle 90°	SRDCN 1616H 06	0162	-	16	16	8.0	100	RC0602
	SRDCN 2020K 06	0163	-	20	20	10.0	125	
	SRDCN 2525M 06	0164	-	25	25	12.5	150	RC0803
	SRDCN 1616H 08C	0727	-	16	16	8.0	100	
	SRDCN 2020K 08C	0728	-	20	20	10.0	125	RC10T3
	SRDCN 2525M 08C	0729	-	25	25	12.5	150	
	SRDCN 1616H 10C	0730	-	16	16	8.0	100	RC1204
	SRDCN 2020K 10C	0731	-	20	20	10.0	125	
	SRDCN 2525M 10C	0732	-	25	25	12.5	150	RC1204
	SRDCN 3232P 10C	0733	-	32	32	16.0	170	
SRDCR/L3232P12C	0737	0738	32	32	40.0	170	RC1204	
SRHCR/L	SRHCR/L 2525K 06	0763	-	25	25	25.0	125	RC0602
	SRHCR/L 2525K 08	0764	0765	25	25	25.0	125	RC0803
	SRHCR/L 2525K 10	0766	0767	25	25	25.0	125	RC10T3
	SRHCR/L 2525K 12	0768	0769	25	25	25.0	125	RC1204

Series	Designation	Information	Clamp	Clamp Screw	Screw	Torx Key
SR..	.06	Description	-	-	Y3008-M2.5x6	Y80-T08
		EDP	-	-	18000124	18000165
	.08	Description	-	-	Y3008-M3x8	Y80-T15
		EDP	-	-	18000125	18000167
	.08C	Description	YACK-15	Y4015-M3.5x11	Y3008-M3x8	Y80-T08
		EDP	18000069	18000118	18000125	18000165
	.10C	Description	YACK-15	Y4015-M3.5x11	Y4015-M3.5x11	Y80-T15
		EDP	18000069	18000118	18000118	18000167
	.12C	Description	YACK-05	Y4015-M4x11	Y4015-M3.5x11	Y80-T15
		EDP	18000065	18000119	18000118	18000167
	.10..12	Description	-	-	Y4015-M3.5x11	Y80-T15
		EDP	-	-	18000118	18000167
.1616..08C	Description	YACK-15	Y4015-M3.5x11	Y3008-M3x8	Y80-T08	
	EDP	18000069	18000118	18000125	18000165	

Screw on type for SC Insert**

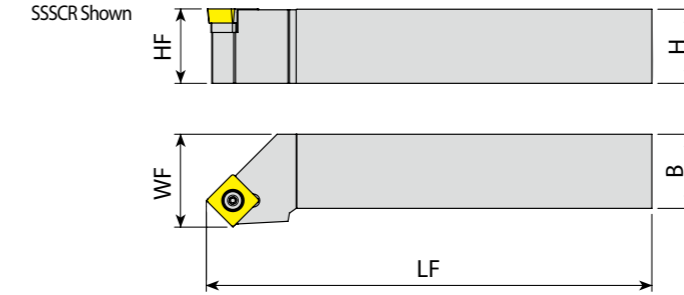

□ : p. 63 Unit: mm

Series	Designation	EDP 2700..		H (= HF)	B	WF	LF	Insert
		R	L					
SSDCN Approach angle 45°	SSDCN 1212F 09	0148	-	12	12	6.0	80	SC09T3
	SSDCN 1616H 09	0149	-	16	16	8.0	100	
	SSDCN 2020K 09	0770	-	20	20	10.0	125	
	SSDCN 1616H 12	0771	-	16	16	8.0	100	SC1204
	SSDCN 2020K 12	0150	-	20	20	10.0	125	
	SSDCN 2525M 12	0151	-	25	25	12.5	150	
SSSCR/L Approach angle 45°	SSSCR/L 1212F 09	0772	0773	12	12	16.0	80	SC09T3
	SSSCR/L 1616H 09	0774	0775	16	16	20.0	100	
	SSSCR/L 2020K 09	0776	0777	20	20	25.0	125	
	SSSCR/L 1616H 12	0778	0779	16	16	20.0	100	SC1204
	SSSCR/L 2020K 12	0780	0781	20	20	25.0	125	
	SSSCR/L 2525M 12	0782	0783	25	25	32.0	150	

Series	Designation	Information	Screw	Shim	Shim Screw	Torx Key
SS..	.1212..09	Description	Y4015-M3.5x11	-	-	Y80-T15
		EDP	18000118	-	-	18000167
	.1616~2020..09	Description	Y4015-M3.5x14	YAASN-2-0001	YAAV-06-M3.5x11	Y80-T15
		EDP	18000129	18000135	18000159	18000167
	.1616..12	Description	Y4020-M4.5x12	YAASN-2-0004	YAAV-10-M4.5x8	Y80-T20
		EDP	18000134	18000144	18000162	18000168
.2020~2525..12	Description	Y1020-M4.5x16	YAASN-2-0004	YAAV-07-M4.5x13	Y80-T20	
	EDP	18000120	18000144	18000160	18000168	

Turning - Holder - External
Screw on type for TC** Insert

STJCR Shown

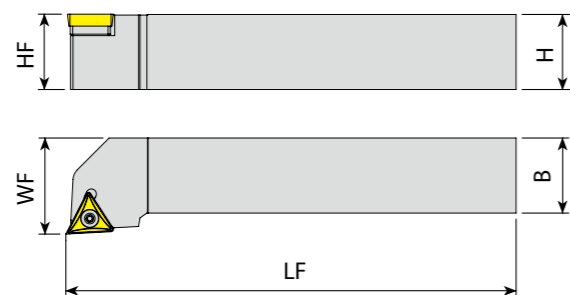

: p. 64 Unit:mm

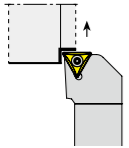
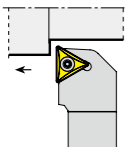
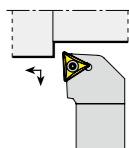
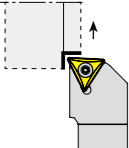
Series	Designation	EDP 2700..		H (= HF)	B	WF	LF	Insert
		R	L					
 STFCR/L Approach angle 91°	STFCR/L 1212F 11	0099	0100	12	12	16	80	TC1102
	STFCR/L 1616H 11	0101	0102	16	16	20	100	
	STFCR/L 1616H 16	0105	0106	16	16	20	100	TC16T3
	STFCR/L 2020K 16	0107	0108	20	20	25	125	
	STFCR/L 2525M 16	0109	0110	25	25	32	150	
	STFCR/L 3232P 16	0784	0785	32	32	40	170	
 STGCR/L Approach angle 91°	STGCR/L 1212F 11	0786	0787	12	12	16	80	TC1102
	STGCR/L 1616H 11	0433	0788	16	16	20	100	
	STGCR/L 1616H 16	0789	0790	16	16	20	100	TC16T3
	STGCR/L 2020K 16	0434	0791	20	20	25	125	
	STGCR/L 2525M 16	0792	0793	25	25	32	150	
	STGCR/L 3232P 16	0794	0795	32	32	40	170	
 STJCR/L Approach angle 93°	STJCR/L 1212F 11	0796	0797	12	12	16	80	TC1102
	STJCR/L 1616H 11	0798	0799	16	16	20	100	
	STJCR/L 1616H 16	0800	0801	16	16	20	100	TC16T3
	STJCR/L 2020K 16	0802	0803	20	20	25	125	
	STJCR/L 2525M 16	0804	0805	25	25	32	150	
	STJCR/L 3232P 16	0806	0807	32	32	40	170	
 STUCR/L Approach angle 93°	STUCR/L 1212F 11	0808	0809	12	12	16	80	TC1102
	STUCR/L 1616H 11	0810	0811	16	16	20	100	
	STUCR/L 1616H 16	0812	0813	20	20	25	125	TC16T3
	STUCR/L 2020K 16	0812	0813	20	20	25	125	
	STUCR/L 2525M 16	0814	0815	25	25	32	150	
	STUCR/L 3232P 16	0816	0817	32	32	40	170	

Series	Designation	Information	Screw	Shim	Shim Screw	Torx Key
ST..	..11	Description	Y4008-M2.5x6	-	-	Y80-T08
		EDP	18000127	-	-	18000165
	..16	Description	Y4015-M3.5x14	YAATN-2-0001	YAAV-06-M3.5x11	Y80-T15
		EDP	18000129	18000146	18000159	18000167

Turning - Holder - External
Screw on type for VB** Insert

SVJBR Shown

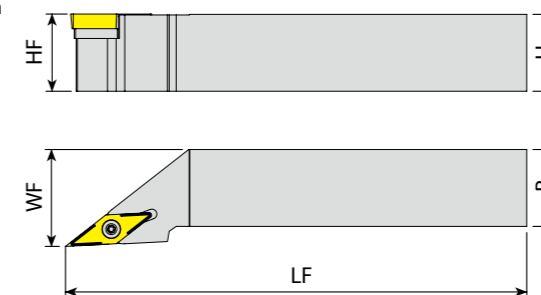

: p. 66 Unit:mm

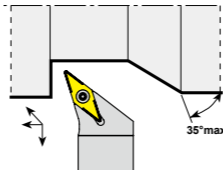
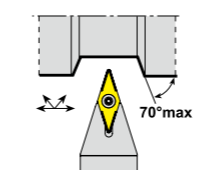
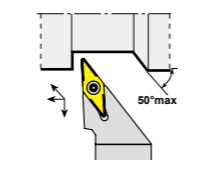
Series	Designation	EDP 2700..		H (= HF)	B	WF	LF	Insert
		R	L					
 SVHBR/L Approach angle 107.5°	SVHBR/L 2020K 16	0818	0819	20	20	25.0	125	VB1604
	SVHBR/L 2525M 16	0820	0821	25	25	32.0	150	
	SVHBR/L 3232P 16	0822	0823	32	32	40.0	170	
 SVVBN Approach angle 72.5°	SVVBN 2020K 16	0131		20	20	10.0	125	VB1604
	SVVBN 2525M 16	0132		25	25	12.5	150	
	SVVBN 3232P 16	0827		32	32	16.0	170	
 SVJBR/L Approach angle 93°	SVJBR/L 1616H 16	0824	0825	16	16	20.0	100	VB1604
	SVJBR/L 2020K 16	0127	0128	20	20	25.0	125	
	SVJBR/L 2525M 16	0129	0130	25	25	32.0	150	
	SVJBR/L 3232P 16	0436	0826	32	32	40.0	170	

Series	Designation	Information	Screw	Shim	Shim Screw	Torx Key
SV..	..16	Description	Y4015-M3.5x14	YAAVN-2-0002	YAAV-06-M3.5x11	Y80-T15
		EDP	18000129	28000043	18000159	18000167

Screw on type for VC Insert**

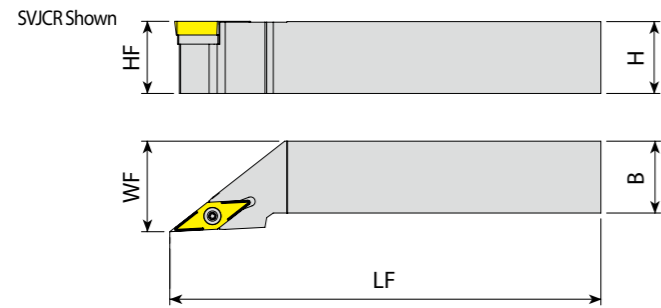

□: p.67 Unit:mm

Series	Designation	EDP 2700.. R L	H (= HF)	B	WF	LF	Insert
 SVHCR/L Approach angle 107.5°	SVHCR/L 2020K 16	0828 0829	20	20	25	125	VC1604
	SVHCR/L 2525M 16	0830 0831	25	25	32	150	
	SVHCR/L 3232P 16	0832 0833	32	32	40	170	
 SVVCN Approach angle 72.5°	SVVCN 1212-F11	0143	12	12	06	80	VC1103
	SVVCN 1616-H11	0144	16	16	08	100	
	SVVCN 2020-K11	0145	20	20	10	125	
	VC1604	SVVCN 2020-K16	0146	20	20	10	125
		SVVCN 2525M 16	0147	25	25	12.5	150
		SVVCN 3232P 16	0838	32	32	16	170
 SVJCR/L Approach angle 93°	SVJCR/L 1212F 16	0834 0835	12	12	16	80	VC1604
	SVJCR/L 2020K 16	0139 0140	20	20	25	125	
	SVJCR/L 2525M 16	0141 0142	25	25	32	150	
	SVJCR/L 3232P 16	0836 0837	32	32	40	170	
	VC1103	SVJCR/L 1212-F11	0133 0134	12	12	16	80
		SVJCR/L 1616-H11	0135 0136	16	16	20	100
		SVJCR/L 2020-K11	0137 0138	20	20	25	125

Series	Designation	Information	Screw	Shim	Shim Screw	Torx Key
SV..	..11	Description	Y4008-M2.5x6	-	-	Y80-T08
		EDP	18000127	-	-	18000165
	..16	Description	Y4015-M3.5x14	YAAVN-2-0002	YAAV-06-M3.5x11	Y80-T15
		EDP	18000129	28000043	18000159	18000167
	..1212..16	Description	Y4015-M3.5x11	-	-	Y80-T15
		EDP	18000118	-	-	18000167
	..2020~3232..16	Description	Y4015-M3.5x14	YAAVN-2-0002	YAAV-06-M3.5x11	Y80-T15
		EDP	18000129	28000043	18000159	18000167

Lever Lock type for CN Insert**

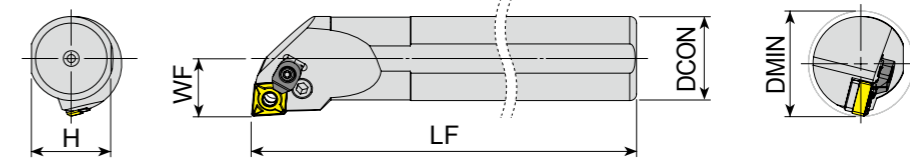

* 'C' Letter at Last : Optional Clamp Included

□: p.30 Unit:mm

Series	Designation	EDP 2700.. R L	DMIN	DCON	H	WF	LF	Insert
●	A25R - PCLNR/L 12C	0839 0840	32	25	23	17	200	CN1204
	A32S - PCLNR/L 12C	0841 0842	40	32	30	22	250	
	A40T - PCLNR/L 12C	0843 0844	50	40	37.5	27	300	
	A50U - PCLNR/L 12C	0845 0846	63	50	47	35	350	
	S25S - PCLNR/L 12C	0863 0864	32	25	23	17	250	
	S32T - PCLNR/L 12C	0865 0866	40	32	30	22	300	
X	S40U - PCLNR/L 12C	0867 0868	50	40	37.5	27	350	CN1606
	S50V - PCLNR/L 12C	0869 0870	63	50	47	35	400	
	A32S - PCLNR/L 16C	0847 0848	40	32	30	22	250	
●	A40T - PCLNR/L 16C	0849 0850	50	40	37.5	27	300	CN1906
	A50U - PCLNR/L 16C	0851 0852	63	50	47	35	350	
	S32T - PCLNR/L 16C	0871 0872	40	32	30	22	300	
	S40U - PCLNR/L 16C	0873 0874	50	40	37.5	27	350	
	S50V - PCLNR/L 16C	0875 0876	63	50	47	35	400	
●	A40T - PCLNR/L 19C	0853 0854	50	40	37.5	27	300	CN1906
	A50U - PCLNR/L 19C	0855 0856	63	50	47	35	350	
	S40U - PCLNR/L 19C	0877 0878	50	40	37.5	27	350	
	S50V - PCLNR/L 19C	0879 0880	63	50	47	35	400	

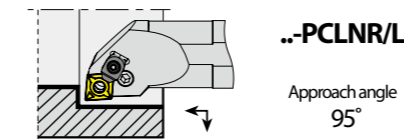

Series	Designation	Information	Lever	Lever Screw	Clamp	Clamp Screw	Shim	Shim Pin	Allen Key
..25..- 12C	Description	YAPL-02	YALV-08-M8x16	YACK-05	Y4015-M4x11	YAACN-3-0001	YAAY-02	YAAL-03-3	
	EDP	18000093	18000104	18000065	18000119	18000137	18000054	18000061	
..32~50..- 12C	Description	YAPL-02	YALV-03-M8x19	YACK-05	Y4015-M4x11	YAACN-3-0001	YAAY-02	YAAL-03-3	
	EDP	18000093	18000100	18000065	18000119	18000137	18000054	18000061	
..PC..	Description	YAPL-04	YALV-04-M8x22	YACK-09	YAAV-05-M6x15	YAACN-3-0002	YAAY-03	YAAL-03-3	
	EDP	18000095	18000101	18000066	18000078	18000138	18000055	18000061	
..19C	Description	YAPL-05	YALV-05-M10x27	YACK-09	YAAV-05-M6x15	YAACN-3-0003	YAAY-04	YAAL-05-4	
	EDP	18000096	18000102	18000066	18000078	18000139	18000056	18000062	
..19C	Description	YAPL-05	YALV-05-M10x27	YACK-09	YAAV-05-M6x15	YAACN-3-0003	YAAY-04	YAAL-05-4	
	EDP	18000096	18000102	18000066	18000078	18000139	18000056	18000062	

Turning - Holder - Internal

Lever Lock type for DN** Insert

..PDQNR Shown

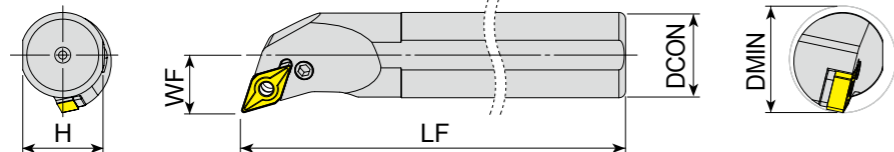

☐: p. 35 Unit:mm

Series	Designation	EDP 2700.. R L	DMIN	DCON	H	WF	LF	Insert
●	A32S - PDQNR/L 1504	0895 -	40	32	30	22	250	DN1504
	A40T - PDQNR/L 1504	0896 -	50	40	37.5	27	300	
	S32T - PDQNR/L 1504	0903 -	40	32	30	22	300	
	X S40U - PDQNR/L 1504	0904 -	50	40	37.5	27	350	
	S50V - PDQNR/L 1504	0905 -	63	50	47	35	400	
●	A32S - PDQNR/L 15	0897 0898	40	32	30	22	250	DN1506
	A40T - PDQNR/L 15	0899 0900	50	40	37.5	27	300	
	A50U - PDQNR/L 15	0901 0902	63	50	47	35	350	
	S32T - PDQNR/L 15	0906 0907	40	32	30	22	300	
	X S40U - PDQNR/L 15	0908 0909	50	40	37.5	27	350	
S50V - PDQNR/L 15	0910 0911	63	50	47	35	400		
●	A32S - PDUNR/L 15	0920 0921	40	32	30	22	250	DN1506
	A40T - PDUNR/L 15	0922 0923	50	40	37.5	27	300	
	A50U - PDUNR/L 15	0924 0925	63	50	47	35	350	
	S25S - PDUNR/L 15	0934 0935	32	25	23	19	250	
	X S32T - PDUNR/L 15	0936 0937	40	32	30	22	300	
S40U - PDUNR/L 15	0938 0939	50	40	37.5	27	350		
S50V - PDUNR/L 15	0940 0941	63	50	47	35	400		

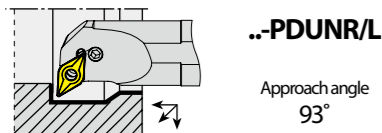
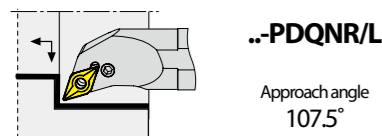

Series	Designation	Information	Lever	Lever Screw	Shim	Shim Pin	Allen Key
..15	Description	YAPL-03	YALV-03-M8x19	YAADN-3-0001	YAAY-02	YAAL-03-3	
	EDP	18000094	18000100	18000142	18000054	18000061	
..1504	Description	YAPL-03	YALV-03-M8x19	YAADN-2-0003	YAAY-02	YAAL-03-3	
	EDP	18000094	18000100	18000141	18000054	18000061	
..25..15	Description	YAPL-03	YALV-08-M8x16	YAADN-3-0001	YAAY-02	YAAL-03-3	
	EDP	18000094	18000104	18000142	18000054	18000061	
..32~50..15	Description	YAPL-03	YALV-03-M8x19	YAADN-3-0001	YAAY-02	YAAL-03-3	
	EDP	18000094	18000100	18000142	18000054	18000061	

Turning - Holder - Internal

Lever Lock type for SN** Insert

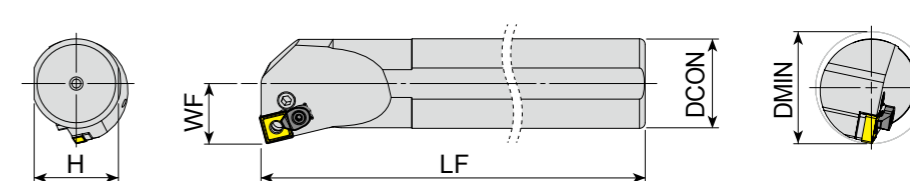

☐: p. 42 Unit:mm

* 'C' Letter at Last : Optional Clamp Included

Series	Designation	EDP 2700.. R L	DMIN	DCON	H	WF	LF	Insert
X	S25S - PSKNR/L 12C	0958 0959	32	25	23	17	250	SN1204
	S32T - PSKNR/L 12C	0960 0961	40	32	30	22	300	
X	S40U - PSKNR/L12C	0962 0963	50	40	37.5	27	350	SN1204
	S50V - PSKNR/L12C	0964 0965	63	50	47	35	400	

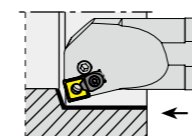

Turning - Holder - Internal Lever Lock type for TN** Insert

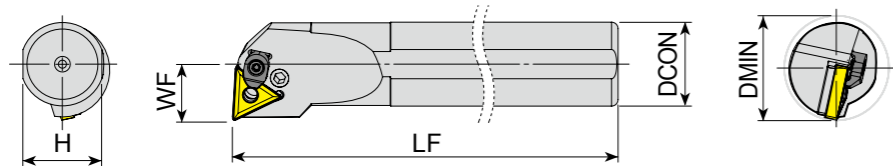

* 'C' Letter at Last : Optional Clamp Included

☐: p. 47 Unit:mm

Series	Designation	EDP 2700.. R L	DMIN	DCON	H	WF	LF	Insert
X	S16P - PTUNR/L 16	1014 1015	20	16	14.8	11	170	TN1604
	S20R - PTUNR/L 16	1016 1017	25	20	18.3	13	200	
	S25S - PTUNR/L 16C	1018 1019	32	25	23	17	250	
	S32T - PTUNR/L 16C	1020 1021	40	32	30	22	300	
	S40U - PTUNR/L 16C	1022 1023	50	40	37.5	27	350	
X	S32T - PTUNR/L 22C	1024 1025	40	32	30	22	300	TN2204
	S40U - PTUNR/L 22C	1026 1027	50	40	37.5	27	350	
	S50V - PTUNR/L 22C	1028 1029	63	50	47	35	400	

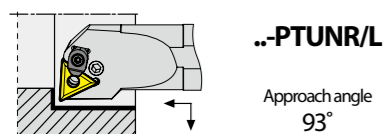

Turning - Holder - Internal Lever Lock type for WN** Insert

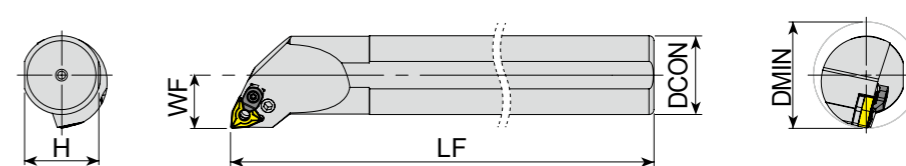

* 'C' Letter at Last : Optional Clamp Included

☐: p. 53 Unit:mm

Series	Designation	EDP 2700.. R L	DMIN	DCON	H	WF	LF	Insert
●	A20P - PWNLR/L 06	1048 1049	25	20	18.3	13	170	WN0604
	A25R - PWNLR/L 06	1050 1051	32	25	23	17	200	
	A32S - PWNLR/L 06	1052 1053	40	32	30	22	250	
X	S20R - PWNLR/L 06	1076 1077	25	20	18.3	13	200	WN0604
	S25S - PWNLR/L 06	1078 1079	32	25	23	17	250	
●	S32T - PWNLR/L 06	1080 1081	40	32	30	22	300	WN0804
	A25R - PWNLR/L 08C	1054 1055	32	25	23	17	200	
	A32S - PWNLR/L 08C	1056 1057	40	32	30	22	250	
X	A40T - PWNLR/L 08C	1058 1059	50	40	37.5	27	300	WN0804
	A50U - PWNLR/L 08C	1060 1061	63	50	47	35	350	
	S25S - PWNLR/L 08C	1082 1083	32	25	23	17	250	
	S32T - PWNLR/L 08C	1084 1085	40	32	30	22	300	
	S40U - PWNLR/L 08C	1086 1087	50	40	37.5	27	350	
	S50V - PWNLR/L 08C	1088 1089	63	50	47	35	400	

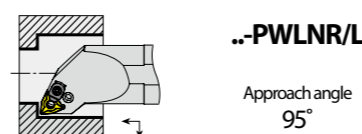

Series	Designation	Infomation	Lever	Lever Screw	Clamp	Clamp Screw	Shim	Shim Pin	Allen Key
..16..16	Description	YAPL-08	YALV-07-M6x13	-	-	-	YAAY-07	YAAL-02-2.5	
	EDP	18000097	18000103	-	-	-	18000057	18000060	
..20..16	Description	YAPL-01	YALV-01-M6x14	-	-	YAATN-3-0025	YAAY-01	YAAL-02-2.5	
	EDP	18000092	18000098	-	-	18000149	18000053	18000060	
..16C	Description	YAPL-01	YALV-02-M6x17	YACK-05	Y4015-M4x11	YAATN-3-0025	YAAY-01	YAAL-02-2.5	
	EDP	18000092	18000099	18000065	18000119	18000149	18000053	18000060	
..22C	Description	YAPL-02	YALV-03-M8x19	YACK-05	Y4015-M4x11	YAATN-3-0015	YAAY-02	YAAL-03-3	
	EDP	18000093	18000100	18000065	18000119	18000148	18000054	18000061	

Series	Designation	Infomation	Lever	Lever Screw	Clamp	Clamp Screw	Shim	Shim Pin	Allen Key
..20..06	Description	YAPL-01	YALV-01-M6x14	-	-	YAAWN-SW317	YAAY-01	YAAL-02-2.5	
	EDP	18000092	18000098	-	-	18000152	18000053	18000060	
..25~32..06	Description	YAPL-01	YALV-02-M6x17	-	-	YAAWN-SW317	YAAY-01	YAAL-02-2.5	
	EDP	18000092	18000099	-	-	18000152	18000053	18000060	
..08C	Description	YAPL-02	YALV-03-M8x19	YACK-05	Y4015-M4x11	YAAWN-3-0001	YAAY-02	YAAL-03-3	
	EDP	18000093	18000100	18000065	18000119	18000151	18000054	18000061	

Turning - Holder - Internal

Double Clamp type for CN** Insert

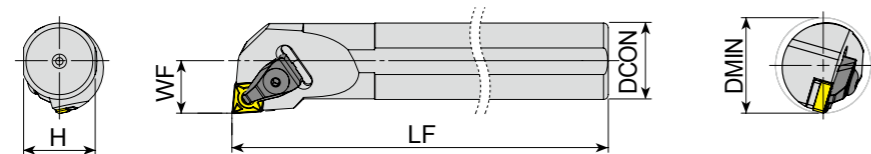

□: p. 30 Unit:mm

Series	Designation	EDP 2700.. R L	DMIN	DCON	H	WF	LF	Insert
X ..-TCLNR/L Approach angle 95°	S25S - TCLNR/L 12	0881 0882	32	25	23	17	250	CN1204
	S32T - TCLNR/L 12	0883 0884	40	32	30	22	300	
	S40U - TCLNR/L 12	0885 0886	50	40	37.5	27	350	
	S50V - TCLNR/L 12	0887 0888	63	50	47	35	400	
	S32T - TCLNR/L 16	0889 0890	40	32	30	22	300	
X	S40U - TCLNR/L 16	0891 0892	50	40	37.5	27	350	CN1606
	S50V - TCLNR/L 16	0893 0894	63	50	47	35	400	

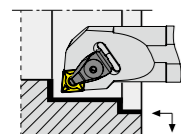

Approach angle 95°

Turning - Holder - Internal

Double Clamp type for DN** Insert

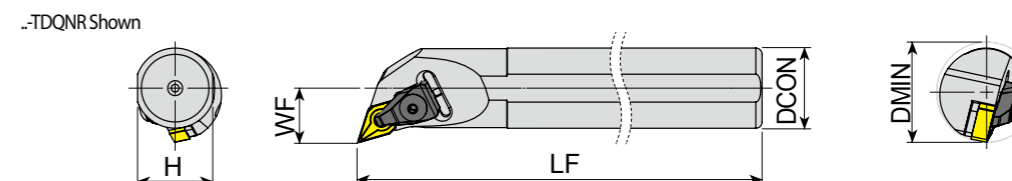

□: p. 35 Unit:mm

Series	Designation	EDP 2700.. R L	DMIN	DCON	H	WF	LF	Insert
X ..-TDQNR/L Approach angle 107.5°	S25S - TDQNR/L 15	0912 0913	32	25	23	17	250	DN1506
	S32T - TDQNR/L 15	0914 0915	40	32	30	22	300	
	S40U - TDQNR/L 15	0916 0917	50	40	37.5	27	350	
	S50V - TDQNR/L 15	0918 0919	63	50	47	35	400	
X ..-TDUNR/L Approach angle 93°	S25S - TDUNR/L 15	0942 0943	34	25	23	17	250	DN1506
	S32T - TDUNR/L 15	0944 0945	40	32	30	22	300	
	S40U - TDUNR/L 15	0946 0947	50	40	37.5	27	350	
	S50V - TDUNR/L 15	0948 0949	63	50	47	35	400	

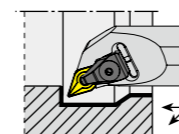

Approach angle 107.5°

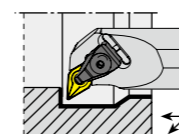

Approach angle 93°

Series	Designation	Infomation	Clamp	Clamp Screw	Upper Ring	Lower Ring	Shim	Shim Screw	Allen Key
..25..12	Description	YATK-02	YAKV-30-M6x22	YABPL-01	YAS-01	YAACN-3-0001	YAAV-13-M5x8	YAAL-03-3	
	EDP	18000075	18000091	18000058	18000052	18000137	18000163	18000061	
..TC.. ..32~50..12	Description	YATK-02	YAKV-30-M6x22	YABPL-01	YAS-01	YAACN-3-0001	YAAV-02-M5x12	YAAL-03-3	
	EDP	18000075	18000091	18000058	18000052	18000137	18000156	18000061	
..16	Description	YATK-04	YAKV-19-M7x25	YABPL-02	-	YAACN-3-0002	YAAV-05-M6x15	YAAL-05-4	
	EDP	18000077	18000088	18000059		18000138	18000078	18000062	

Series	Designation	Infomation	Clamp	Clamp Screw	Upper Ring	Lower Ring	Shim	Shim Screw	Allen Key
..TDQ..25..15	Description	YATK-02	YAKV-30-M6x22	YABPL-01	-	YAADN-3-0001	YAAV-13-M5x8	YAAL-03-3	
	EDP	18000075	18000091	18000058		18000142	18000163	18000061	
..TD.. ..25..15	Description	YATK-02	YAKV-30-M6x22	YABPL-01	YAS-01	YAADN-3-0001	YAAV-13-M5x8	YAAL-03-3	
	EDP	18000075	18000091	18000058	18000052	18000142	18000163	18000061	
..32~50..15	Description	YATK-02	YAKV-30-M6x22	YABPL-01	YAS-01	YAADN-3-0001	YAAV-02-M5x12	YAAL-03-3	
	EDP	18000075	18000091	18000058	18000052	18000142	18000156	18000061	

Double Clamp type for SN** Insert

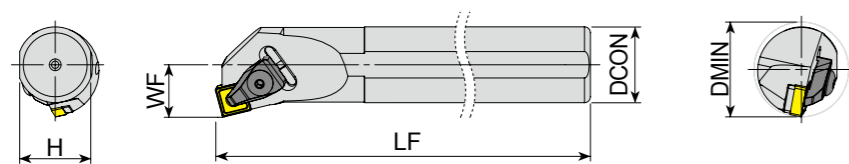

□: p. 42 Unit: mm

Series	Designation	EDP 2700..		DMIN	DCON	H	WF	LF	Insert
		R	L						
..-TSKNR/L	S25S - TSKNR/L 12	0966	-	32	25	23	17	250	SN1204
	S32T - TSKNR/L12	0968	0969	40	32	30	22	300	
	S40U - TSKNR/L 12	0970	0971	50	40	37.5	27	350	

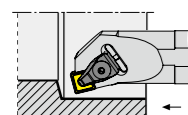

..-TSKNR/L

Approach angle 75°

X

Series	Designation	Information	Clamp	Clamp Screw	Upper Ring	Lower Ring	Shim	Shim Screw	Allen Key
..TS..	..12	Description	YATK-02	YAKV-30-M6x22	YABPL-01	YAS-01	YAASN-3-0004	YAAV-13-M5x8	YAAL-03-3
		EDP	18000075	18000091	18000058	18000052	18000145	18000163	18000061

Double Clamp type for TN** Insert

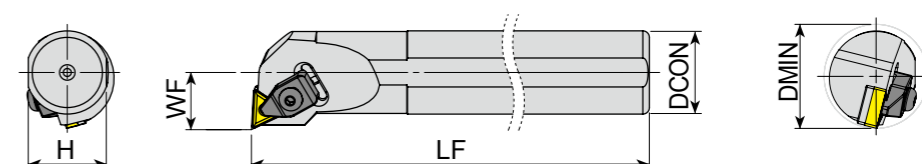

□: p. 47 Unit: mm

Series	Designation	EDP 2700..		DMIN	DCON	H	WF	LF	Insert
		R	L						
..-TTUNR/L	S25S - TTUNR/L 16	1030	1031	32	25	23	17	250	TN1604
	S32T - TTUNR/L 16	1032	1033	40	32	30	22	300	
	S25S - TTUNR/L 22	1034	1035	32	25	23	17	250	TN2204
	S32T - TTUNR/L 22	1036	1037	40	32	30	22	300	
	S40U - TTUNR/L 22	1038	1039	50	40	37.5	27	350	
	S50V - TTUNR/L 22	1040	1041	63	50	47	35	400	

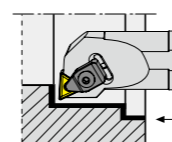

..-TTUNR/L

Approach angle 93°

Series	Designation	Information	Clamp	Clamp Screw	Upper Ring	Lower Ring	Shim	Shim Screw	Allen Key
..TT..	..16	Description	YATK-01	YAKV-01-M5x22	YABPL-01	-	YAATN-2-0002	YAAV-03-M5x12	YAAL-03-3
		EDP	18000074	18000080	18000058		18000147	18000156	18000061
	..22	Description	YATK-02	YAKV-30-M6x22	YABPL-01	YAS-01	YAATN-3-0015	YAAV-02-M5x12	YAAL-03-3
		EDP	18000075	18000091	18000058	18000052	18000148	18000156	18000061

Turning - Holder - Internal

Double Clamp type for VN** Insert

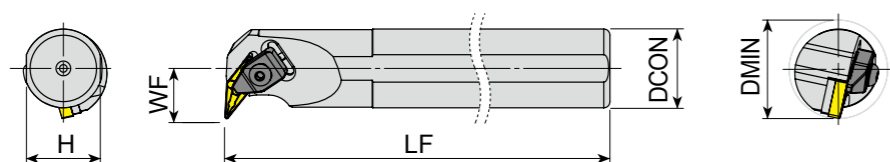

: p. 51 Unit:mm

Series	Designation	EDP 2700.. R L	DMIN	DCON	H	WF	LF	Insert
..-TVUNR/L	S25S - TVUNR/L 16	1042 1043	36	25	23	20	250	VN1604
	S32T - TVUNR/L 16	1044 1045	40	32	30	22	300	
	S40U - TVUNR/L 16	1046 1047	50	40	37.5	27	350	

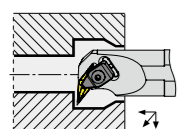

..-TVUNR/L

Approach angle
93°

X

Series	Designation	Infomation	Clamp	Clamp Screw	Upper Ring	Shim	Shim Screw	Allen Key
..TV..	..16	Description	YATK-01	YAKV-01-M5x22	YABPL-01	YAAVN-2-0002	YAAV-04-M5x12	YAAL-03-3
		EDP	18000074	18000080	18000058	18000150	18000185	18000061

Turning - Holder - Internal

Double Clamp type for WN** Insert

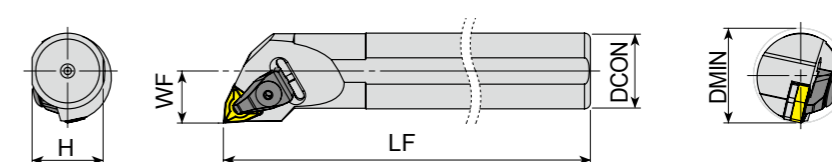

: p. 53 Unit:mm

Series	Designation	EDP 2700.. R L	DMIN	DCON	H	WF	LF	Insert
X	S25S - TWLNR/L 06	1090 1091	32	25	23	17	250	WN0604
	S32T - TWLNR/L 06	1092 1093	40	32	30	22	300	
●	A40T - TWLNR/L 08	1062 -	50	40	37.5	27	300	WN0804
	A50U - TWLNR/L 08	1063 -	63	50	47	35	350	
X	S25S - TWLNR/L 08	1094 1095	32	25	23	17	250	
	S32T - TWLNR/L 08	1096 1097	40	32	30	22	300	
	S40U - TWLNR/L 08	1098 1099	50	40	37.5	27	350	
	S50V - TWLNR/L 08	1100 1101	63	50	47	35	400	

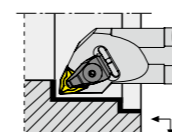

..-TWLNR/L

Approach angle
95°

Series	Designation	Infomation	Clamp	Clamp Screw	Upper Ring	Lower Ring	Shim	Shim Screw	Allen Key
..TW..	..06	Description	YATK-01	YAKV-01-M5x22	YABPL-01	-	YAAWN-SW317	YAAV-01-M3x10	YAAL-03-3
		EDP	18000074	18000080	18000058		18000152	18000155	18000061
..TW..	..25..08	Description	YATK-02	YAKV-30-M6x22	YABPL-01	YAS-01	YAAWN-3-0001	YAAV-13-M5x8	YAAL-03-3
		EDP	18000075	18000091	18000058	18000052	18000151	18000163	18000061
..TW..	..32~50..08	Description	YATK-02	YAKV-30-M6x22	YABPL-01	YAS-01	YAAWN-3-0001	YAAV-02-M5x12	YAAL-03-3
		EDP	18000075	18000091	18000058	18000052	18000151	18000156	18000061

Turning - Holder - Internal Multi-Clamp type for CN** Insert

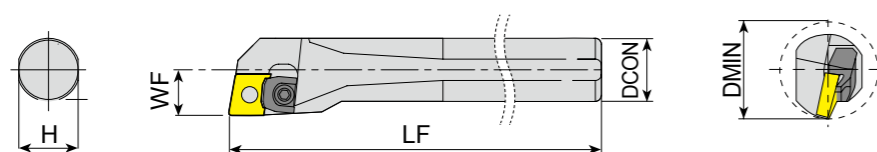

□: p. 30 Unit:mm

Series	Designation	EDP 2700.. R L	DMIN	DCON	H	WF	LF	Insert
..- MCLNR/L	S20R - MCLNR/L12	0857 0858	25	20	18.3	13	200	CN1204
	S32T - MCLNR/L12	0861 0862	40	32	30	22	300	

Approach angle 95°

Series	Designation	Infomation	Clamp	Clamp Screw	Shim	Shim Pin	Allen Key
..MC..	..20..12	Description	YAMK-07	YAKV-04-M5x17	-	YAPM-12	YAAL-03-3
		EDP	28000019	18000082	-	28000025	18000061
	..32..12	Description	YAMK-03	-	YAACN-3-0001	YAPM-04	-
		EDP	28000020	-	18000137	18000113	-

Turning - Holder - Internal Multi-Clamp type for DN** Insert

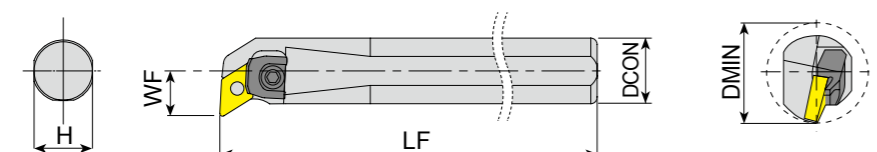

□: p. 35 Unit:mm

Series	Designation	EDP 2700.. R L	DMIN	DCON	H	WF	LF	Insert
..- MDUNR/L	S32T - MDUNR/L15	0928 0929	40	32	30	22	300	DN1506
	S40U - MDUNR/L15	0930 0931	50	40	37.5	27	350	
	S50V - MDUNR/L15	0932 0933	63	50	47	35	400	

Approach angle 93°

Series	Designation	Infomation	Clamp	Clamp Screw	Upper Ring	Lower Ring	Shim	Shim Pin	Allen Key
..MD..	..15	Description	YAMK-04	YAKV-30-M6x22	YABPL-01	YAS-01	YAADN-3-0001	YAPM-04	YAAL-03-3
		EDP	18000072	18000091	18000058	18000052	18000142	18000113	18000061

Turning - Holder - Internal Multi-Clamp type for TN** Insert

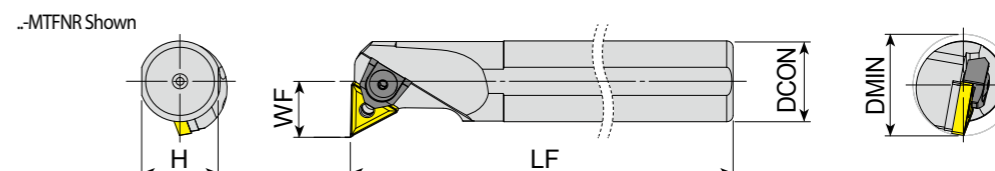

□: p. 47 Unit:mm

Series	Designation	EDP 2700.. R L	DMIN	DCON	H	WF	LF	Insert	
..- MTFNR/L	S20R - MTFNR/L 16	0972 -	25	20	18.3	14	200	TN1604	
	S25S - MTFNR/L 16	0973 0974	32	25	23	17	250		
	S32T - MTFNR/L 16	0975 0976	40	32	30	22	300		
	S40U - MTFNR/L 16	0977 0978	50	40	37.5	27	350		
..- MTQNR/L	S32T - MTFNR/L 22	0979 0980	40	32	30	22	300	TN2204	
	S40U - MTFNR/L 22	0981 0982	50	40	37.5	27	350		
	S50V - MTFNR/L 22	0983 -	63	50	47	35	400		
..- MTQNR/L	S20R - MTQNR/L 16	0984 0985	25	20	18.3	13	200	TN1604	
	S32T - MTQNR/L 16	0988 0989	40	32	30	22	300		
	S40U - MTQNR/L 16	0990 0991	50	40	37.5	27	350		
	S32T - MTQNR/L 22	0992 0993	40	32	30	22	300		
	S40U - MTQNR/L 22	0994 0995	50	40	37.5	27	350		
	S50V - MTQNR/L 22	0996 0997	63	50	47	35	400		
..- MTUNR/L	S32T - MTUNR/L 22	1008 1009	40	32	30	22	300	TN2204	
	S40U - MTUNR/L 22	1010 1011	50	40	37.5	27	350		
	S50V - MTUNR/L 22	1012 1013	63	50	47	35	400		
	S20R - MTUNR/L 16	0998 0999	25	20	18.3	13	200		TN1604
	S25S - MTUNR/L 16	1000 1001	32	25	23	17	250		
..- MTUNR/L	S32T - MTUNR/L 16	1002 1003	40	32	30	22	300	TN1604	
	S40U - MTUNR/L 16	1004 1005	50	40	37.5	27	350		
	S50V - MTUNR/L 16	1006 1007	63	50	47	35	400		

Approach angle 91°

Approach angle 107.5°

Approach angle 93°

Series	Designation	Infomation	Clamp	Clamp Screw	Upper Ring	Lower Ring	Pin	Shim	Shim Pin	Allen Key
..20..16	Description	YAMK-02	YAKV-17-M5x15	-	-	YAPM-03	-	-	-	YAAL-03-3
	EDP	18000071	18000087	-	-	18000112	-	-	-	18000061
..22	Description	YAMK-04	YAKV-30-M6x22	YABPL-01	YAS-01	YAPM-02	YAATN-3-0015	-	-	YAAL-03-3
	EDP	18000072	18000091	18000058	18000052	18000054	18000148	-	-	18000061
..25..16	Description	YAMK-04	YAKV-30-M6x22	YABPL-01	YAS-01	YAPM-14	YAATN-2-0002	-	-	YAAL-03-3
	EDP	18000072	18000091	18000058	18000052	18000117	18000147	-	-	18000061
..32~40..16	Description	YAMK-04	YAKV-30-M6x22	YABPL-01	YAS-01	-	YAATN-2-0002	YAPM-14	YAAL-03-3	
	EDP	18000072	18000091	18000058	18000052	-	18000147	18000117	18000061	
..32~50..16	Description	YAMK-04	YAKV-30-M6x22	YABPL-01	YAS-01	YAPM-01	YAATN-2-0002	-	-	YAAL-03-3
	EDP	18000072	18000091	18000058	18000052	18000110	18000147	-	-	18000061
..32~50..22	Description	YAMK-04	YAKV-30-M6x22	YABPL-01	YAS-01	-	YAATN-3-0015	YAPM-02	YAAL-03-3	
	EDP	18000072	18000091	18000058	18000052	-	18000148	18000111	18000061	

Multi-Clamp type for WN** Insert

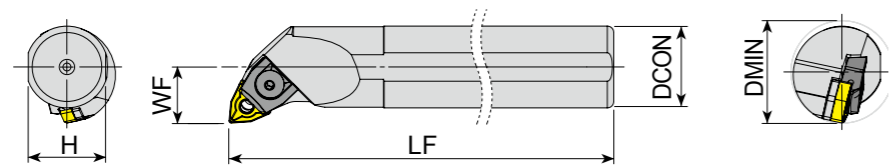

□: p.53 Unit:mm

Series	Designation	EDP 2700.. R L	DMIN	DCON	H	WF	LF	Insert
..-MWLNR/L Approach angle 95°	S16P - MWLNR/L 06	1064 1065	20	16	14.8	11	170	WN0604
	X S20R - MWLNR/L 06	1066 1067	25	20	18.3	13	200	
	S25S - MWLNR/L 06	1068 1069	32	25	23	17	250	
	S25S - MWLNR/L 08	1070 1071	32	25	23	17	250	WN0804
	X S32T - MWLNR/L 08	1072 1073	40	32	30	22	300	
	S40U - MWLNR/L 08	1074 1075	50	40	37.5	27	350	

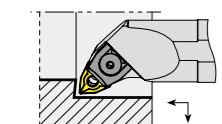

Top Clamp type for KN** Insert

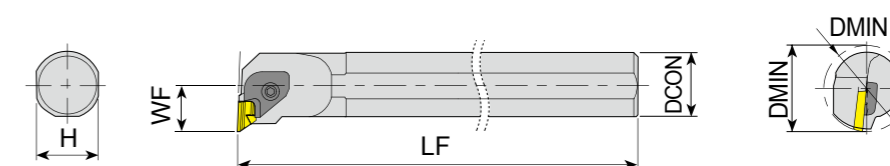

□: p.41 Unit:mm

Series	Designation	EDP 2700.. R L	DMIN	DCON	H	WF	LF	Insert
..-CKUNR/L Approach angle 93°	S32T - CKUNR/L16	0952 0953	40	32	30	22	300	KN1604
	X S40U - CKUNR/L16	0954 0955	50	40	37.5	27	350	
	S50V - CKUNR/L16	0956 0957	63	50	47	35	400	

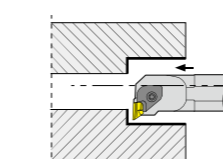

Series	Designation	Infomation	Clamp	Clamp Screw	Upper Ring	Lower Ring	Pin	Shim	Allen Key
..MW..	..16..06	Description	YAMK-01	YAKV-17-M5x15	-	-	YAPM-09	-	-
		EDP	18000070	18000087			18000115		
	..20..06	Description	YAMK-01	YAKV-04-M5x17	-	-	YAPM-10	-	-
		EDP	18000070	18000082			18000116		
	..25..06	Description	YAMK-01	YAKV-04-M5x17	-	-	YAPM-08	-	-
		EDP	18000070	18000082			18000114		
..25..08	Description	YAMK-05	YAKV-27-M6x20	YABPL-01	YAS-01	YAPM-04	YAAWN-3-0001	YAAL-03-3	
	EDP	18000073	18000090	18000058	18000052	18000113	18000151	18000061	
..32~40..08	Description	YAMK-05	YAKV-03-M6x22	YABPL-01	YAS-01	YAPM-02	YAAWN-3-0001	YAAL-03-3	
	EDP	18000073	18000081	18000058	18000052	18000111	18000151	18000061	

Series	Designation	Infomation	Clamp	Clamp Screw	Spring	Upper Ring	Shim	Shim Screw	Allen Key
..CK..	..16	Description	YACK-01-R	YAKV-06-M6x20	YAKY-02	YABPL-01	YAKS-16-R	YAAV-01-M3x10	YAAL-05-4
			YACK-02-L				YAKS-16-L		
		EDP	18000064 (18000063)	18000083	18000164	18000058	18000154 (18000153)	18000155	18000062

Turning - Holder - Internal Screw on type for CC** Insert

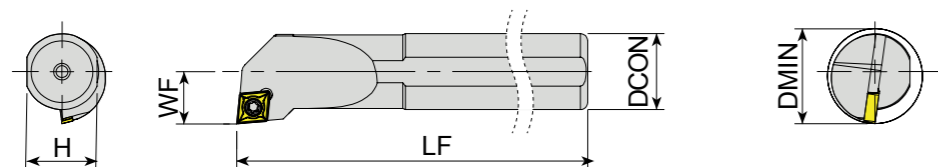

□: p.57 Unit:mm

Series	Designation	EDP 2700.. R	L	DMIN	DCON	H	WF	LF	Insert
X	S08H - SCFCR/L 06	1102	1103	11	08	7.3	6	100	CC0602
	S10K - SCFCR/L 06	1104	1105	13	10	9	7	125	
	S12K - SCFCR/L 06	1106	1107	16	12	11	9	125	
X	S12K - SCFCR/L 09	1108	1109	16	12	11	9	125	CC09T3
	S16P - SCFCR/L 09	1110	1111	20	16	14.8	11	170	
	S20R - SCFCR/L 09	1112	1113	25	20	18.3	13	200	
	S25S - SCFCR/L 09	1114	1115	32	25	23	17	250	
X	S25S - SCFCR/L 12	1116	-	32	25	23	17	250	CC1204

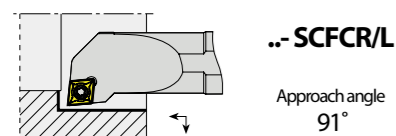

..- SCFCR/L
Approach angle
91°

▶ NEXT PAGE

Series	Designation	Infomation	Screw	Shim	Shim Screw	Torx Key
..06	Description		Y4008-M2.5x6	-	-	Y80-T08
	EDP		18000127	-	-	18000165
..12	Description		Y4020-M4.5x12	YAACN-2-0003	YAAV-10-M4.5x8	Y80-T20
	EDP		18000134	18000136	18000162	18000168
..12..09	Description		Y4015-M3.5x8	-	-	Y80-T15
	EDP		18000130	-	-	18000167
..16~20..09	Description		Y4015-M3.5x9	-	-	Y80-T15
	EDP		18000131	-	-	18000167
..25..09	Description		Y4015-M3.5x12	YAACN-2-0001	YAAV-08-M3.5x8	Y80-T15
	EDP		18000128	18000135	18000161	18000167

Turning - Holder - Internal Screw on type for CC** Insert

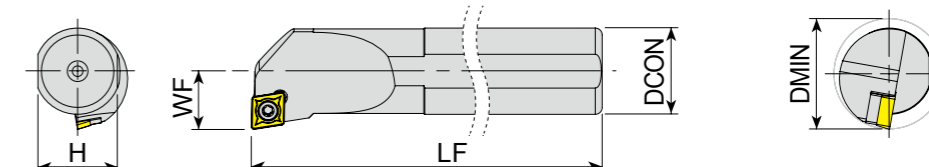

□: p.57 Unit:mm

Series	Designation	EDP 2700.. R	L	DMIN	DCON	H	WF	LF	Insert
●	A08H - SCLCR/L 06	1117	1118	11	08	7.3	6	100	CC0602
	A10H - SCLCR/L 06	1119	1120	13	10	9	7	100	
	A12H - SCLCR/L 06	1121	1122	16	12	11	9	100	
X	S08H - SCLCR/L 06	1133	1134	11	08	7.3	6	100	CC0602
	S10K - SCLCR/L 06	1135	1136	13	10	9	7	125	
	S12K - SCLCR/L 06	1137	1138	16	12	11	9	125	
	S16P - SCLCR/L 06	1139	1140	20	16	14.8	11	170	
●	A16M - SCLCR/L 09	1123	1124	20	16	14.8	11	150	CC09T3
	A20P - SCLCR/L 09	1125	1126	25	20	18.3	13	170	
	A25R - SCLCR/L 09	1127	1128	32	25	23	17	200	
X	A32S - SCLCR/L 09	1129	1130	40	32	30	22	250	CC09T3
	S12K - SCLCR/L 09	1141	1142	16	12	11	9	125	
	S16P - SCLCR/L 09	1474	1143	20	16	14.8	11	170	
	S20R - SCLCR/L 09	1144	1145	25	20	18.3	13	200	
●	S25S - SCLCR/L 09	1146	1147	32	25	23	17	250	CC1204
	S32T - SCLCR/L 09	1148	1149	40	32	30	22	300	
	A25R - SCLCR/L 12	1131	1132	32	25	23	17	200	
X	S25S - SCLCR/L 12	1150	1151	32	25	23	17	250	CC1204
	S32T - SCLCR/L 12	1152	1153	40	32	30	22	300	
●	S40U - SCLCR/L 12	1154	1155	50	40	37.5	27	350	CC1204
	E08K - SCLCR/L 06	0325	1156	11	08	7.3	6	125	
●	E12Q - SCLCR/L 06	1157	1158	16	12	11	9	180	CC0602
	E16R - SCLCR/L 09	0329	1159	20	16	14.8	11	200	
●	E20S - SCLCR/L 09	1160	1161	24	20	18.3	13	250	CC09T3

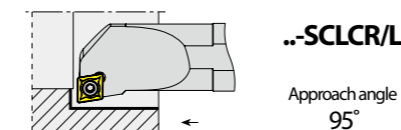

..-SCLCR/L
Approach angle
95°

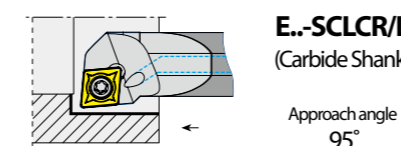

E..-SCLCR/L
(Carbide Shank)
Approach angle
95°

Series	Designation	Infomation	Screw	Shim	Shim Screw	Torx Key
..06	Description		Y4008-M2.5x6	-	-	Y80-T08
	EDP		18000127	-	-	18000165
..12..09	Description		Y4015-M3.5x8	-	-	Y80-T15
	EDP		18000130	-	-	18000167
..16~20..09	Description		Y4015-M3.5x9	-	-	Y80-T15
	EDP		18000131	-	-	18000167
..25~32..09	Description		Y4015-M3.5x12	YAACN-2-0001	YAAV-08-M3.5x8	Y80-T15
	EDP		18000128	18000135	18000161	18000167
..25~32..12	Description		Y4020-M4.5x12	YAACN-2-0003	YAAV-10-M4.5x8	Y80-T20
	EDP		18000134	18000136	18000162	18000168
..40..12	Description		Y1020-M4.5x16	YAACN-2-0003	YAAV-07-M4.5x13	Y80-T20
	EDP		18000120	18000136	18000160	18000168
E..SC..	Description		Y4008-M2.5x6	-	-	Y80-T08
	EDP		18000127	-	-	18000165
..09	Description		Y4015-M3.5x9	-	-	Y80-T15
	EDP		18000131	-	-	18000167

Turning - Holder - Internal Screw on type for DC** Insert

..SDQCR Shown

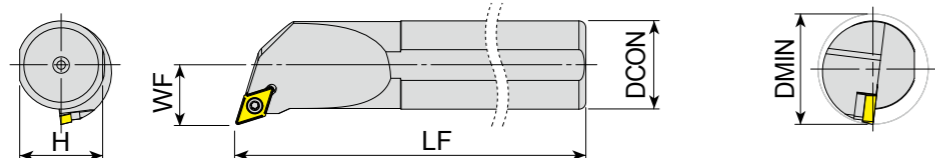

□: p. 59 Unit:mm

Series	Designation	EDP 2700.. R	EDP 2700.. L	DMIN	DCON	H	WF	LF	Insert
..SDPCR/L Approach angle 117.5°	S10K - SDPCR/L07	1162	1163	13	10	9	7	125	DC0702
	S12K - SDPCR/L07	1164	1165	16	12	11	9	125	
	S16P - SDPCR/L11	1166	1167	20	16	14.8	11	170	DC11T3
	S25S - SDPCR/L11	1170	1171	32	25	23	17	250	
..SDQCR/L Approach angle 107.5°	A10H - SDQCR/L 07	1172	1173	13	10	9	7	100	DC0702
	A12H - SDQCR/L 07	1174	1175	16	12	11	9	100	
	A16M - SDQCR/L 07	1176	1177	20	16	14.8	11	150	
	A20P - SDQCR/L 07	1178	1179	25	20	18.3	13	170	
	S10K - SDQCR/L 07	1188	1189	13	10	9	7	125	
	S12K - SDQCR/L 07	1190	1191	16	12	11	9	125	
	S16P - SDQCR/L 07	1192	1193	20	16	14.8	11	170	
	S20R - SDQCR/L 07	1194	1195	25	20	18.3	13	200	
..SDQCR/L Approach angle 107.5°	A16M - SDQCR/L 11	1180	1181	20	16	14.8	11	150	DC11T3
	A20P - SDQCR/L 11	1182	1183	25	20	18.3	13	170	
	A25R - SDQCR/L 11	1184	1185	32	25	23	17	200	
	A32S - SDQCR/L 11	1186	1187	40	32	30	22	250	
	S16P - SDQCR/L 11	1196	1197	20	16	14.8	11	170	
	S20R - SDQCR/L 11	1198	1199	25	20	18.3	13	200	
	S25S - SDQCR/L 11	1200	1201	32	25	23	17	250	
	S32T - SDQCR/L 11	1202	1203	40	32	30	22	300	
S40U - SDQCR/L 11	1204	1205	50	40	37.5	27	350		

▶ NEXT PAGE

Series	Designation	Information	Screw	Shim	Shim Screw	Torx Key
..07	Description		Y4008-M2.5x6	-	-	Y80-T08
	EDP		18000127	-	-	18000165
..11	Description		Y4008-M2.5x6	-	-	Y80-T15
	EDP		18000127	-	-	18000167
..16..11	Description		Y4015-M3.5x9	-	-	Y80-T15
	EDP		18000131	-	-	18000167
..20..11	Description		Y4015-M3.5x11	-	-	Y80-T15
	EDP		18000118	-	-	18000167
..25..11	Description		Y4015-M3.5x12	YAADN-2-0001	YAAV-08-M3.5x8	Y80-T15
	EDP		18000128	18000140	18000162	18000167
..32..11	Description		Y4015-M3.5x14	YAADN-2-0001	YAAV-06-M3.5x11	Y80-T15
	EDP		18000129	18000140	18000159	18000162

Turning - Holder - Internal Screw on type for DC** Insert

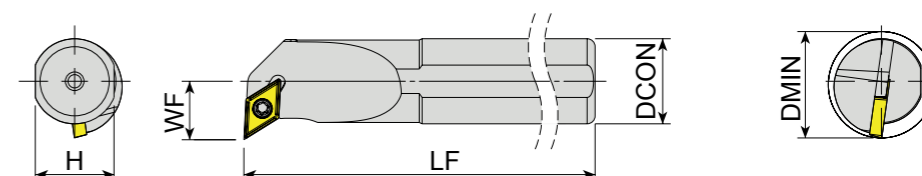

□: p. 59 Unit:mm

Series	Designation	EDP 2700.. R	EDP 2700.. L	DMIN	DCON	H	WF	LF	Insert	
..SDUCR/L Approach angle 93°	A10H - SDUCR/L 07	1206	1207	13	10	9	8	100	DC0702	
	A12H - SDUCR/L 07	1208	1209	16	12	11	9	100		
	A16M - SDUCR/L 07	1210	1211	20	16	14.8	11	150		
	A20P - SDUCR/L 07	1212	1213	25	20	18.3	13	170		
	S10K - SDUCR/L 07	1222	1223	13	10	9	8	125		
	S12K - SDUCR/L 07	1224	1225	16	12	11	9	125		
	S16P - SDUCR/L 07	1226	1227	20	16	14.8	11	170		
	S20R - SDUCR/L 07	1228	1229	25	20	18.3	13	200		
	A16M - SDUCR/L 11	1214	1215	20	16	14.8	11	150		
	A20P - SDUCR/L 11	1216	1217	25	20	18.3	13	170		
E..SDUCR/L (Carbide Shank) Approach angle 93°	A25R - SDUCR/L 11	1218	1219	32	25	23	17	200	DC0702	
	A32S - SDUCR/L 11	1220	1221	40	32	30	22	250		
	S16P - SDUCR/L 11	1230	1231	20	16	14.8	11	170		
	S20R - SDUCR/L 11	1232	1233	25	20	18.3	13	200		
	S25S - SDUCR/L 11	1234	1235	32	25	23	17	250		
	S32T - SDUCR/L 11	1236	1237	40	32	30	22	300		
	S40U - SDUCR/L 11	1238	1239	50	40	37.5	27	350		
	S50V - SDUCR/L 11	-	1240	63	50	47	35	400		
	E10M - SDUCR/L 07	1241	1242	13	10	9	8	150		DC11T3
	E12Q - SDUCR/L 07	1243	1244	16	12	11	9	180		
E16R - SDUCR/L 11	0339	1245	20	16	14.8	11	200	DC11T3		
	E20S - SDUCR/L 11	1246	1247	23	20	18.3	12		250	

Series	Designation	Information	Screw	Shim	Shim Screw	Torx Key
..07	Description		Y4008-M2.5x6	-	-	Y80-T08
	EDP		18000127	-	-	18000165
..16..11	Description		Y4015-M3.5x9	-	-	Y80-T15
	EDP		18000131	-	-	18000167
..20..11	Description		Y4015-M3.5x11	-	-	Y80-T15
	EDP		18000118	-	-	18000167
..25..11	Description		Y4015-M3.5x12	YAADN-2-0001	YAAV-08-M3.5x8	Y80-T15
	EDP		18000128	18000140	18000161	18000167
..32..11	Description		Y4015-M3.5x14	YAADN-2-0001	YAAV-06-M3.5x11	Y80-T15
	EDP		18000129	18000140	18000159	18000167
E..07	Description		Y4008-M2.5x6	-	-	Y80-T08
	EDP		18000127	-	-	18000165
E..11	Description		Y4015-M3.5x9	-	-	Y80-T15
	EDP		18000131	-	-	18000167

Turning - Holder - Internal Screw on type for RC** Insert

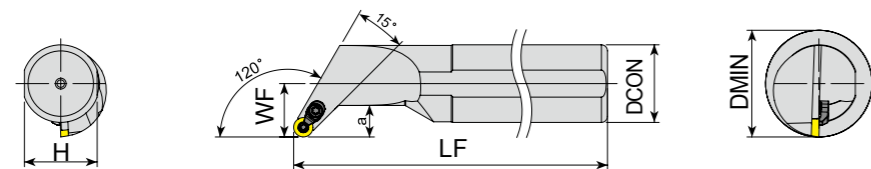

*'C' Letter at Last : Optional Clamp Included

□: p.61 Unit:mm

Series	Designation	EDP 2700.. R	L	DMIN	DCON	H	WF	LF	Insert
X ..- SRGCR/L	S16P - SRGCR/L08	1248	-	22	16	14.8	11	170	RC0803
	S40U - SRGCR 08C	1254	-	54	40	37.5	27	350	
	S32T - SRGCR/L08C	1253	-	44	32	30	22	300	
	S25S - SRGCR/L08C	1251	1252	34	25	23	17	250	

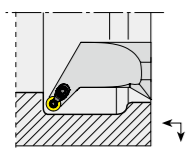

TURNING

PARTING & GROOVING

MILLING

DRILLING

TECHNICAL INFORMATION

Series	Designation	Infomation	Screw	Clamp	Clamp Screw	Torx Key
..SR..	.08	Description	Y3008-M3x8	-	-	Y80-T08
		EDP	18000125			18000165
	.08C	Description	Y3008-M3x8	YACK-15	Y4015-M3.5x11	Y80-T08
		EDP	18000125	18000069	18000118	18000165

Turning - Holder - Internal Screw on type for SC** Insert

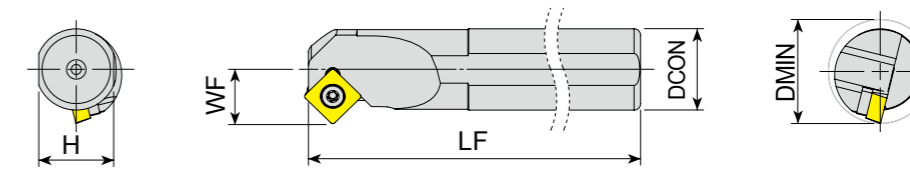

□: p.63 Unit:mm

Series	Designation	EDP 2700.. R	L	DMIN	DCON	H	WF	LF	Insert
X ..- SSSCR/L	S16P - SSSCR/L09	1255	1256	20	16	14.8	11	170	SC09T3
	S25S - SSSCR/L09	1259	1260	32	25	23	17	250	
	S25S - SSSCR/L12	1261	1262	32	25	23	17	250	SC1204
	S32T - SSSCR12	1263	-	40	32	30	22	300	

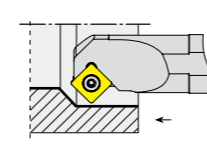

Approach angle
45°

TURNING

PARTING & GROOVING

MILLING

DRILLING

TECHNICAL INFORMATION

Series	Designation	Infomation	Screw	Shim	Shim Screw	Torx Key
..SS..	..16..09	Description	Y4015-M3.5x9	-	-	Y80-T15
		EDP	18000131			18000167
	..25..09	Description	Y4015-M3.5x12	YAASN-2-0001	YAAV-08-M3.5x8	Y80-T15
		EDP	18000128	18000143	18000161	18000167
	..25..12	Description	Y4020-M4.5x12	YAASN-2-0004	YAAV-10-M4.5x8	Y80-T20
		EDP	18000134	18000144	18000162	18000168
..32..12	Description	Y1020-M4.5x16	YAASN-2-0004	YAAV-10-M4.5x8	Y80-T20	
	EDP	18000120	18000144	18000162	18000168	

Turning - Holder - Internal Screw on type for TC** Insert

..STFCR Shown

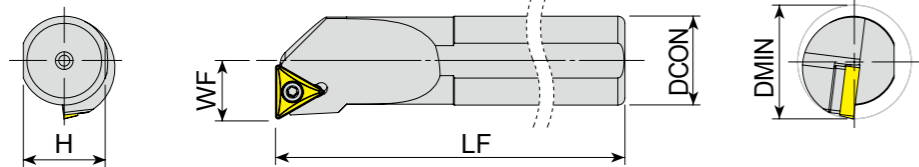

□: p.64 Unit:mm

Series	Designation	EDP 2700.. R L	DMIN	DCON	H	WF	LF	Insert	
..STFCR/L Approach angle 91°	S12K - STFCR/L 11	1264 1265	17	12	11	9	125	TC1102	
	X S16P - STFCR/L 11	1266 1267	20	16	14.8	11	170		
	S20R - STFCR/L 11	1268 1269	25	20	18.3	13	200		
	..STUCR/L Approach angle 93°	S16P - STUCR/L 16	1270 1271	20	16	14.8	11	170	TC1102
		X S20R - STUCR/L 16	1272 1273	25	20	18.3	13	200	
		S25S - STFCR/L 16	1274 1275	32	25	23	17	250	
..STUCR/L Approach angle 93°		S32T - STFCR/L 16	1276 1277	40	32	30	22	300	TC16T3
		S40U - STFCR/L 16	1278 -	50	40	37.5	27	350	
		S12K - STUCR/L 11	1279 1280	17	12	11	9	125	
	X S16P - STUCR/L 11	1281 1282	20	16	14.8	11	170		
	S20R - STUCR/L 11	1283 1284	25	20	18.3	13	200		
	..STUCR/L Approach angle 93°	S16P - STUCR/L 16	1285 1286	20	16	14.8	11	170	TC1102
X S20R - STUCR/L 16		1287 1288	25	20	18.3	13	200		
S25S - STUCR/L 16		1289 1290	32	25	23	17	250		
..STUCR/L Approach angle 93°		S32T - STUCR/L 16	1291 1292	40	32	30	22	300	TC16T3
		S40U - STUCR/L 16	1293 1294	50	40	37.5	27	350	

Series	Designation	Information	Screw	Shim	Shim Screw	Torx Key
..11	Description		Y4008-M2.5x6	-	-	Y80-T08
	EDP		18000127	-	-	18000165
..12~20..11	Description		Y4008-M2.5x6	-	-	Y80-T08
	EDP		18000127	-	-	18000165
..16..16	Description		Y4015-M3.5x9	-	-	Y80-T15
	EDP		18000131	-	-	18000167
..20..16	Description		Y4015-M3.5x11	-	-	Y80-T15
	EDP		18000118	-	-	18000167
..25..16	Description		Y4015-M3.5x14	YAATN-2-0001	YAAV-08-M3.5x8	Y80-T15
	EDP		18000129	18000146	18000161	18000167
..32~40..16	Description		Y4015-M3.5x14	YAATN-2-0001	YAAV-06-M3.5x11	Y80-T15
	EDP		18000129	18000146	18000159	18000167

Turning - Holder - Internal Screw on type for VB** Insert

..STFCR Shown

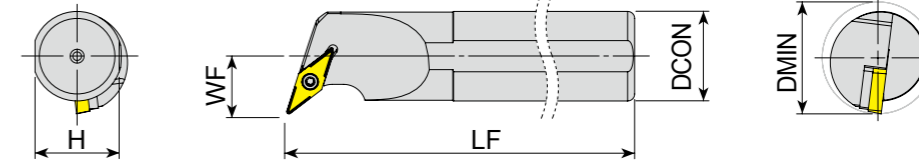

□: p.66 Unit:mm

Series	Designation	EDP 2700.. R L	DMIN	DCON	H	WF	LF	Insert
..SVQBR/L Approach angle 107.5°	A20Q - SVQBR/L 16	1299 1300	30	20	18.3	20	180	VB1604
	● A25S - SVQBR/L 16	1301 1302	32	25	23	17	250	
	A32S - SVQBR/L 16	1303 1304	40	32	30	22	250	
	S25S - SVQBR/L 16	1305 1306	32	25	23	17	250	
	X S32T - SVQBR/L 16	1307 1308	40	32	30	22	300	
	S40U - SVQBR/L 16	1309 1310	50	40	37.5	27	350	
..SVJBR/L Approach angle 93°	S25S - SVJBR/L 16	1295 1296	32	25	23	17	250	VB1604
	X S32T - SVJBR/L 16	1297 1298	40	32	30	22	300	
..SVUBR/L Approach angle 93°	● A20Q - SVUBR/L 16	1311 -	30	20	18.3	20	180	VB1604
	A32S - SVUBR/L 16	1312 1313	40	32	30	22	250	
	S25S - SVUBR/L 16	1314 1315	32	25	23	19	250	
	X S32T - SVUBR/L 16	1316 1317	40	32	30	22	300	
	S40U - SVUBR/L 16	1318 1319	50	40	37.5	27	350	

Series	Designation	Information	Screw	Shim	Shim Screw	Torx Key
..20..16	Description		Y4015-M3.5x11	-	-	Y80-T15
	EDP		18000118	-	-	18000167
A - ..25..16	Description		Y4015-M3.5x14	YAAVN-2-0002	YAAV-06-M3.5x11	Y80-T15
	EDP		18000129	18000150	18000159	18000167
S - ..25..16	Description		Y4015-M3.5x14	YAAVN-2-0002	YAAV-08-M3.5x8	Y80-T15
	EDP		18000129	18000150	18000161	18000167
..SV.. ..32~40..16	Description		Y4015-M3.5x14	YAAVN-2-0002	YAAV-06-M3.5x11	Y80-T15
	EDP		18000129	18000150	18000159	18000167
..16	Description		Y4015-M3.5x12	YAAVN-2-0002	YAAV-08-M3.5x8	Y80-T15
	EDP		18000128	18000150	18000161	18000167
..25~40..16	Description		Y4015-M3.5x14	YAAVN-2-0002	YAAV-06-M3.5x11	Y80-T15
	EDP		18000129	18000150	18000159	18000167

Screw on type for VC Insert**

..SVQCR Shown

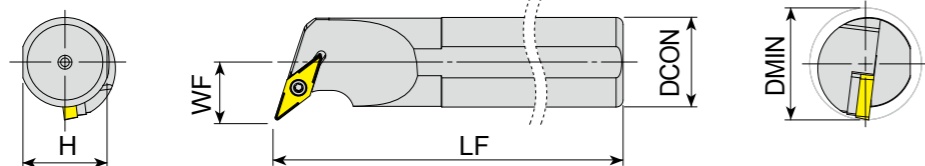

□: p.67 Unit:mm

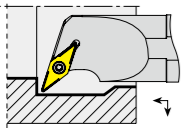
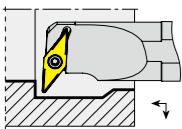
Series	Designation	EDP 2700.. R L	DMIN	DCON	H	WF	LF	Insert
 ..-SVQCR/L Approach angle 107.5°	S25S - SVQCR/L 16	1320 1321	32	25	23	17	250	VC1604
	S32T - SVQCR/L 16	1322 1323	40	32	30	22	300	
	S40U - SVQCR/L 16	1324 1325	50	40	37.5	27	350	
 ..-SVUCR/L Approach angle 93°	S16P - SVUCR/L11	1495 1496	20	16	14.8	12.5	170	VC1103
	S20R - SVUCR/L11	1497 1498	25	20	18.3	13	200	VC1604
	● A25R - SVUCR/L 16	1326 -	32	25	23	19	200	
	S25S - SVUCR/L 16	1327 1328	32	25	23	19	250	
	X S32T - SVUCR/L 16	1329 1330	40	32	30	22	300	
	S40U - SVUCR/L 16	1331 1332	50	40	37.5	27	350	

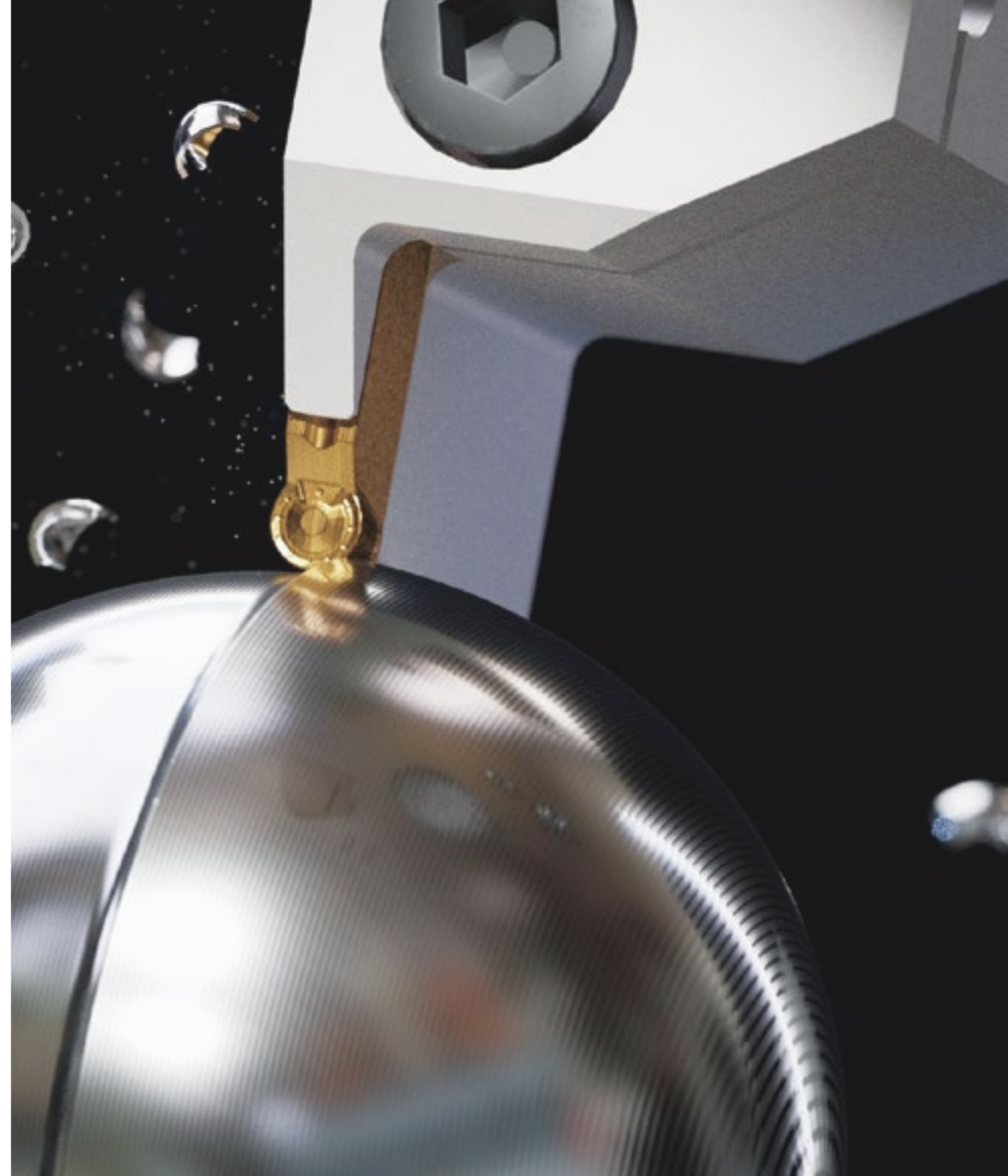

PARTING & GROOVING

Parting & Grooving Inserts Overview

Parting & Grooving Inserts

Parting & Grooving Holders

Series	Designation	Information	Screw	Shim	Shim Screw	Torx Key
..11	Description		Y4008-M2.5x6	-	-	Y80-T08
	EDP		18000127	-	-	18000165
..16	Description		Y4015-M3.5x14	YAAVN-2-0002	YAAV-06-M3.5x11	Y80-T15
	EDP		18000129	18000150	18000159	18000167
..25..16	Description		Y4015-M3.5x14	YAAVN-2-0002	YAAV-08-M3.5x8	Y80-T15
	EDP		18000129	18000150	18000161	18000167
..32~40..16	Description		Y4015-M3.5x14	YAAVN-2-0002	YAAV-06-M3.5x11	Y80-T15
	EDP		18000129	18000150	18000159	18000167

Parting & Grooving
Parting & Grooving Overview

Parting & Groove Turn Grades



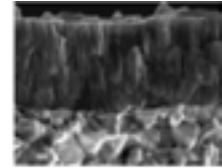
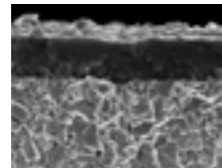





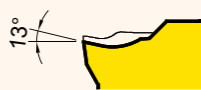

Parting and Grooving Grades	P Steel				M Stainless steel				K Cast iron			N Non Ferrous		S Super Alloy	
	P10	P20	P30	P40	M10	M20	M30	M40	K10	K20	K30	N10	N20	S10	S20
PVD	YG602G (YG602)	602G				602G				602G					602G
	YG603					603									

<p>YG602G (YG602)</p> <p>P20 - P35 M20 - M40 K20 - K40 S15 - S25</p>	<p>PVD - TiAlN</p> 	<p>Universal grade for Parting & Groove Turn</p> <ul style="list-style-type: none"> Ultra Dense PVD Coating with optimal thermal resistance & strength Sub-Micron substrate designed for demanding application YG602G : First Choice for Low Cutting Speed, Soft and Sticky Material with Low Hardness (Gold Color) YG602 : First Choice for General Application (Violet Color)
<p>YG603</p> <p>M30 - M50</p>	<p>PVD - TiAlN</p> 	<p>PVD Parting & Grooving Grade for Stainless Steel</p> <ul style="list-style-type: none"> Ultra high toughness substrate and strong adhesion Excellent cutting edge strength and chipping resistance Stable machinability and tool life for stainless steel

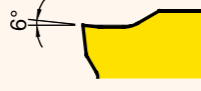
Parting & Grooving Inserts

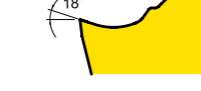
	TD. Series	Inserts TDN, TDP, TDY	2, 3, 4, 5
---	------------	--------------------------	------------

Parting & Grooving Chipbreakers

Parting & Grooving	-P			<ul style="list-style-type: none"> For Parting & Deep Grooving For Low Feed Rate and Difficult to Cut Materials
	-N			<ul style="list-style-type: none"> For External Parting And Grooving For General Use
Turning & Grooving	-Y			<ul style="list-style-type: none"> For External Turning & Grooving For Medium feed rate
	NEW GL			<ul style="list-style-type: none"> For External, Internal turning and Grooving Face grooving and Face turning For low feed rate
	NEW GM			<ul style="list-style-type: none"> For External, Internal turning and Grooving First choice Face Grooving and Face turning For Medium feed rate
	NEW RG			<ul style="list-style-type: none"> For External, Internal turning and Grooving Full radius Insert for Profiling

Parting & Grooving
Parting & Grooving Inserts

Recommended Cutting Conditions : p.222

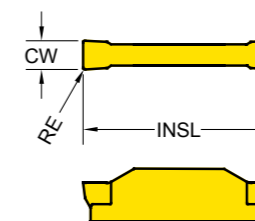

Series	INSL	CW
TD* 2	20	2
TD* 3	20	3
TD* 4	20	4
TD* 5	25	5

* CDX : Cutting Depth Maximum

● : Stock item ○ : Order made item

TD.	Designation	RE	Parting & Grooving		Turning		EDP 5200..		
			Fn (mm/rev.)	CDX (mm)	Fn (mm/rev.)	Ap (mm)	YG602	YG602G	YG603
-P	TDP 2002	0.2	0.04 ~ 0.12	19	-	-	●	○	●
	TDP 3002	0.2	0.05 ~ 0.16	19	-	-	●	○	●
	TDP 4003	0.3	0.06 ~ 0.18	19	-	-	●	○	●
	* TDPR 2002 - 6	0.2	0.03 ~ 0.08	19	-	-	●	○	●
	* TDPR 3002 - 6	0.2	0.04 ~ 0.12	19	-	-	●	○	●
	* TDPL 2002 - 6	0.2	0.03 ~ 0.08	19	-	-	●	○	●
-N	* TDPL 3002 - 6	0.2	0.04 ~ 0.12	19	-	-	●	○	●
	TDN 2002	0.2	0.05 ~ 0.18	19	-	-	●	○	●
	TDN 3002	0.2	0.07 ~ 0.23	19	-	-	●	○	●
	TDN 4003	0.3	0.08 ~ 0.28	19	-	-	●	○	●
	TDN 5003	0.3	0.09 ~ 0.35	24	-	-	●	○	●
	* TDNR 2002 - 6	0.2	0.04 ~ 0.14	19	-	-	●	○	●
	* TDNR 3002 - 6	0.2	0.06 ~ 0.18	19	-	-	●	○	●
	* TDNL 2002 - 6	0.2	0.04 ~ 0.14	19	-	-	●	○	●
	* TDNL 3002 - 6	0.2	0.06 ~ 0.18	19	-	-	●	○	●
	* TDNL 4003 - 6	0.3	0.06 ~ 0.24	19	-	-	●	○	●
-Y	TDY3E - 0.4	0.4	0.06 ~ 0.24	10	0.12 ~ 0.22	0.5 ~ 2.4	●	○	●
	TDY4E - 0.4	0.4	0.08 ~ 0.27	10	0.15 ~ 0.30	0.5 ~ 2.8	●	○	●
	TDY5E - 0.4	0.4	0.08 ~ 0.23	10	0.15 ~ 0.30	0.5 ~ 3.2	●	○	●
	TDY2E - 0.3 - GL	0.3	0.04 ~ 0.20	10	0.06 ~ 0.18	0.4 ~ 1.5	●	○	●
	TDY3E - 0.3 - GL	0.3	0.05 ~ 0.23	10	0.08 ~ 0.20	0.4 ~ 2.0	●	○	●
	NEW GL TDY4E - 0.4 - GL	0.4	0.06 ~ 0.26	10	0.10 ~ 0.25	0.5 ~ 2.3	●	○	●
	TDY3E - 0.4 - GM	0.4	0.06 ~ 0.24	10	0.12 ~ 0.22	0.5 ~ 2.4	●	○	●
	TDY4E - 0.4 - GM	0.4	0.08 ~ 0.27	10	0.15 ~ 0.30	0.5 ~ 2.8	●	○	●
	NEW GM TDY4E - 0.8 - GM	0.8	0.10 ~ 0.27	10	0.18 ~ 0.32	0.8 ~ 2.8	●	○	●
	TDY2E - 1.0 - RG	1.0	0.05 ~ 0.15	10	0.10 ~ 0.30	0.1 ~ 0.8	●	○	●
	TDY3E - 1.5 - RG	1.5	0.08 ~ 0.18	10	0.15 ~ 0.35	0.1 ~ 1.2	●	○	●
	NEW RG TDY4E - 2.0 - RG	2.0	0.10 ~ 0.20	10	0.18 ~ 0.45	0.1 ~ 1.6	●	○	●

Parting & Grooving - Holder - External
External holders

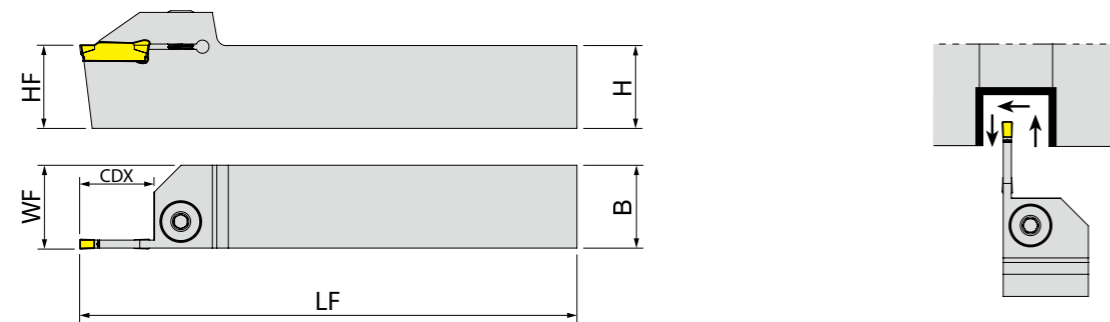

: p. 119 Unit :mm

Designation	EDP 5700..		CW	CDX	H (= HF)	B	LF	WF	Insert
	R	L							
YTER/L 1212 - 2T15	0025	0024	2	15	12	12	100	12.3	TD2..
YTER/L 1616 - 2T15	0027	0026	2	15	16	16	125	16.3	
YTER/L 2020 - 2T15	0030	0029	2	15	20	20	125	20.3	
YTER/L 2020 - 2T20	0032	0031	2	20	20	20	125	20.3	
YTER/L 2020 - 2T9	0028	-	2	9	20	20	125	20.3	
YTER/L 2525 - 2T17	0034	0033	2	17	25	25	150	25.3	
YTER/L 1212 - 3T15	0036	0035	3	15	12	12	100	12.4	TD3..
YTER/L 1616 - 3T15	0038	0037	3	15	16	16	125	16.4	
YTER/L 2020 - 3T20	0040	0039	3	20	20	20	125	20.4	
YTER/L 2525 - 3T20	0044	0043	3	20	25	25	150	25.4	
YTER/L 2525 - 3T9	0042	0041	3	9	25	25	150	25.4	
YTER/L 3232 - 3T20	0045	-	3	20	32	32	170	32.4	
YTER/L 2525 - 4T20	0047	0046	4	20	25	25	150	25.5	TD4..

▶ NEXT PAGE

Series	Designation	Information	Screw	Ring	Wrench
YTER/L	..2..	Description	YAKV-02-M6x22	YABPL-01	YAAL-03-3
		EDP	18000195	18000058	18000061
	..3.. / ..4.. / ..5..	Description	Y2004-M8x1x20	-	YAAL-05-4
		EDP	18000196	-	18000062

Parting & Grooving - Holder - External
External holders

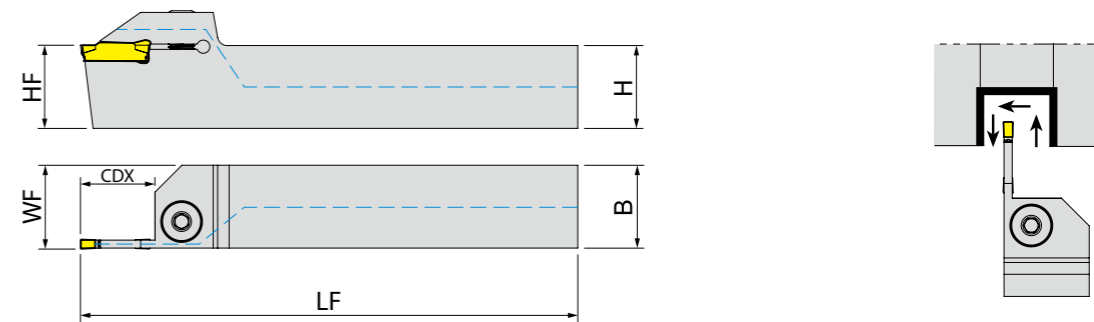

: p. 119 Unit :mm

Designation	EDP 5700..		CW	CDX	H (= HF)	B	LF	WF	Insert
	R	L							
YTER/L 1212 - 2T15 - C	● 0194	0171	2	15	12	12	100	12.3	TD2..
YTER/L 1616 - 2T15 - C	● 0197	0174	2	15	16	16	125	16.3	
YTER/L 2020 - 2T15 - C	● 0201	0178	2	15	20	20	125	20.3	
YTER/L 2020 - 2T17 - C	● 0202		2	17	20	20	125	20.3	
YTER/L 2020 - 2T20 - C	● 0203	0179	2	20	20	20	125	20.3	
YTER/L 2020 - 2T09 - C	● 0204	0180	2	09	20	20	125	20.3	
YTER/L 2525 - 2T17 - C	● 0208	0184	2	17	25	25	150	25.3	TD3..
YTER/L 1212 - 3T15 - C	● 0196	0173	3	15	12	12	100	12.4	
YTER/L 1616 - 3T15 - C	● 0199	0176	3	15	16	16	125	16.4	
YTER/L 2020 - 3T20 - C	● 0205	0181	3	20	20	20	125	20.4	
YTER/L 2020 - 3T25 - C	● 0206	0182	3	25	20	20	125	20.4	
YTER/L 2020 - 3T30 - C	● 0207	0183	3	30	20	20	125	20.4	
YTER/L 2525 - 3T22 - C	● 0209	0185	3	22	25	25	150	25.4	TD4..
YTER/L 2525 - 3T25 - C	● 0210	0186	3	25	25	25	150	25.4	
YTER/L 2525 - 3T30 - C	● 0211	0187	3	30	25	25	150	25.4	
YTER/L 2525 - 3T09 - C	● 0212	0188	3	09	25	25	150	25.4	
YTER/L 3232 - 3T25 - C	● 0217	0192	3	25	32	32	170	32.4	
YTER/L 2525 - 4T22 - C	● 0213	0189	4	22	25	25	150	25.5	
YTER/L 2525 - 4T25 - C	● 0214		4	25	25	25	150	25.5	TD5..
YTER/L 2525 - 4T30 - C	● 0215	0190	4	30	25	25	150	25.5	
YTER/L 2525 - 5T25 - C	● 0216	0191	5	25	25	25	150	25.5	

Series	Designation	Information	Screw	Ring	Wrench
YTER/L	..2..	Description	YAKV-02-M6x22	YABPL-01	YAAL-03-3
		EDP	18000195	18000058	18000061
	..3.. / ..4.. / ..5..	Description	Y2004-M8X1X20	-	YAAL-05-4
		EDP	18000196	-	18000062

Parting & Grooving - Holder - External
External holders- Face grooving NEW

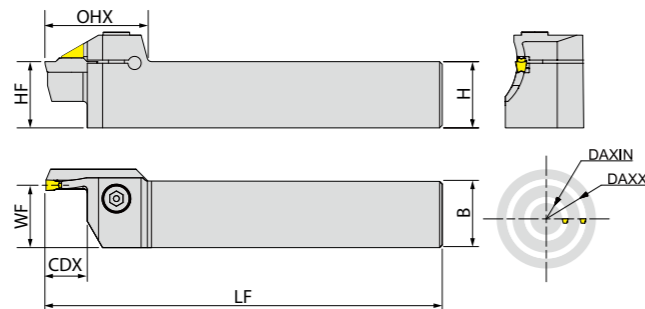

: p. 119 Unit :mm

Designation	EDP 5700.. R L	CW	DAXIN	DAXX	CDX	H (= HF)	B	LF	WF	Insert
YTFR 25M-D034050-3T10A	0599 -	3	34	50	10	25	25	150	24	TD3..
YTFR 25M-D044060-3T15A	0600 -	3	44	60	15	25	25	150	24	
YTFR 25M-D054085-3T15A	0601 -	3	54	85	15	25	25	150	24	
YTFR 25M-D034050-4T15A	0602 -	4	34	50	15	25	25	150	23.6	TD4..
YTFR 25M-D042060-4T15A	0603 -	4	42	60	15	25	25	150	23.6	
YTFR 25M-D052072-4T20A	0604 -	4	52	72	20	25	25	150	23.6	
YTFR 25M-D064120-4T20A	0605 -	4	64	120	20	25	25	150	23.6	
YTFR 25M-D112200-4T20A	0606 -	4	112	200	20	25	25	150	23.6	
YTFR 25M-D200-4T20A	0607 -	4	200	-	20	25	25	150	23.6	

Series	Designation	Infomation	Screw	Ring	Wrench
YTFR	..S	Description	SHB-M6x1.0x25L	-	HL-05
		EDP	58000039	-	58000041

Parting & Grooving - Holder - External
External holders - Perpendicular Face grooving NEW

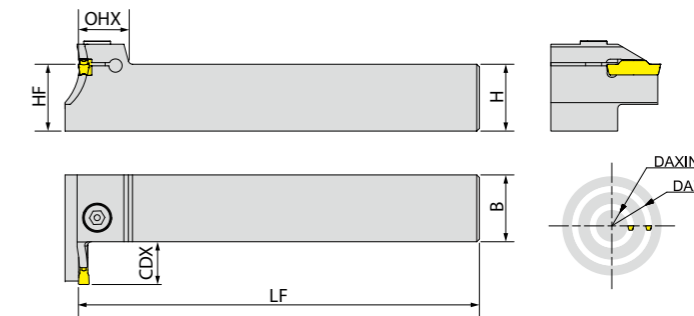

: p. 119 Unit :mm

Designation	EDP 5700.. R L	CW	DAXIN	DAXX	CDX	H (= HF)	B	LF	Insert
YTFPR25M - D034050 - 3T12A	0608 -	3	34	50	12	25	25	150	TD3..
YTFPR25M - D044060 - 3T15A	0609 -	3	44	60	15	25	25	150	
YTFPR25M - D054085 - 3T15A	0610 -	3	54	85	15	25	25	150	
YTFPR25M - D034050 - 4T15A	0611 -	4	34	50	15	25	25	150	TD4..
YTFPR25M - D042060 - 4T15A	0612 -	4	42	60	15	25	25	150	
YTFPR25M - D052072 - 4T20A	0613 -	4	52	72	20	25	25	150	
YTFPR25M - D064120 - 4T20A	0614 -	4	64	120	20	25	25	150	
YTFPR25M - D112200 - 4T20A	0615 -	4	112	200	20	25	25	150	

Series	Designation	Infomation	Screw	Ring	Wrench
YTFPR	16-2T..	Description	SHB-M6x1.0x25L	-	HL-05
		EDP	58000039	-	58000041
	20~25-3T..	Description	SHB-M6x1.0x25L	-	HL-05
		EDP	58000039	-	58000041
	32-3T..	Description	SHB-M6x1.0x25L	-	HL-05
		EDP	58000039	-	58000041

Parting & Grooving - Holder - External
External holders (Swiss Lathe)

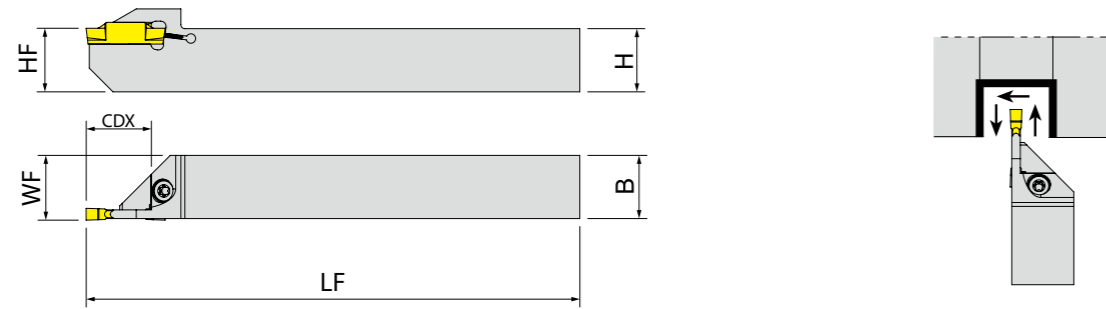

: p. 119 Unit :mm

Designation	EDP 5700..		CW	CDX	H (= HF)	B	LF	WF	Insert
	R	L							
YTER/L 1212-2T12-S	0048	-	2	12	12	12	125	12.2	TD.2..
YTER/L 1616-2T16-S	0049	-	2	16	16	16	125	16.2	
YTER/L 1212-3T12-S	0051	0050	3	12	12	12	125	12.3	TD.3..
YTER/L 1616-3T16-S	0053	0052	3	16	16	16	125	16.3	
YTER/L 1212-2T12-S-C	● 0193	0170	2	12	12	12	125	12.2	TD.2..
YTER/L 1616-2T16-S-C	● 0198	0175	2	16	16	16	125	16.2	
YTER/L 1212-3T12-S-C	● 0195	0172	3	12	12	12	125	12.3	TD.3..
YTER/L 1616-3T16-S-C	● 0200	0177	3	16	16	16	125	16.3	

Series	Designation	Information	Screw	Ring	Wrench
YTER/L	..S	Description	Y4015-M4x11	-	Y80-T15
		EDP	18000119	-	18000167

Parting & Grooving - Holder - Internal
Internal holders with Coolant supply

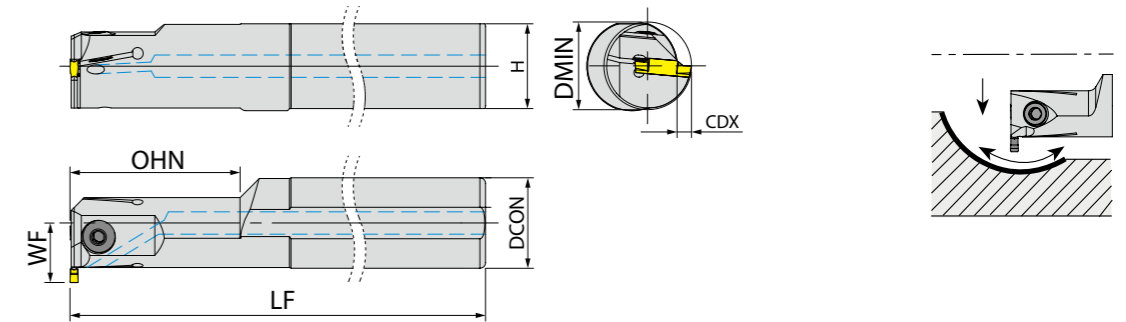

: p. 119 Unit :mm

Designation	EDP 5700..		CW	DMIN	CDX	DCON	H (= HF)	OHN	LF	WF	Insert
	R	L									
YTIR/L 16-2T8.5-C	● 0222	0218	2	25	8.5	16	14.8	28	150	16.5	TD.2..
YTIR/L 20-3T06-C	● 0223	0219	3	25	6	20	18.3	40	170	16	
YTIR/L 25-3T06-C	● 0224	0220	3	25	6	25	23	40	200	18.5	TD.3..
YTIR/L 32-3T05-C	● 0225	0221	3	31	5	32	30	60	250	21	

Series	Designation	Information	Screw	Ring	Wrench
YTIR/L	16-2T..	Description	Y2503-M4X10	-	YAAL-03-3
		EDP	18000197	-	18000061
	20-3T..	Description	Y2504-M5X12	-	YAAL-05-4
		EDP	18000198	-	18000062
	25-3T..	Description	Y2504-M5X16	-	YAAL-05-4
		EDP	58000028	-	18000062
32-3T..	Description	Y2004-M8X1X20	-	YAAL-05-4	
	EDP	18000196	-	18000062	

Parting & Grooving - Holder
Blade

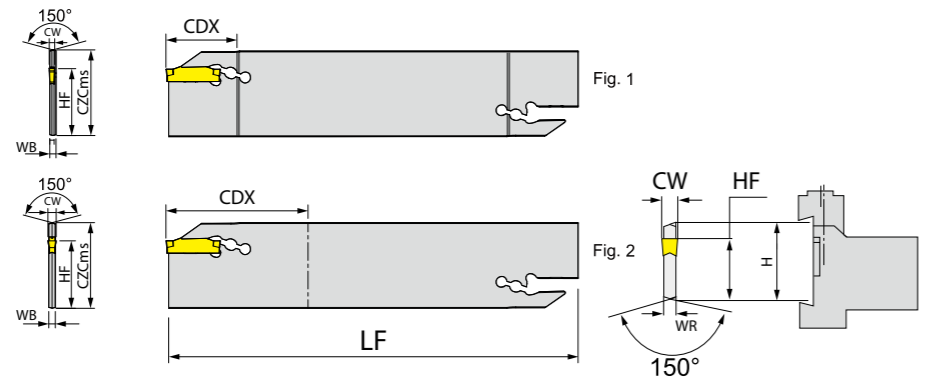

: p. 119 Unit:mm

Designation	EDP 5700..	CZCms	CW	CDX	HF	LF	WB	Insert	Fig
YGB 32 - 2	0058	32	2	25	25	150	2.4	TD.2..	1
YGB 32 - 3	0059	32	3	50	25	150	2.4	TD.3..	2
YGB 32 - 2 - C	● 0226	32	2	25	25	150	2.4	TD.2..	1
YGB 32 - 3 - C	● 0227	32	3	50	25	150	2.4	TD.3..	2

Series	Designation	Infomation	Screw	Ring	Wrench
YGB..	..-32..	Description	-	-	YALA-02
		EDP	-	-	58000027

Parting & Grooving - Holder
Blade Block

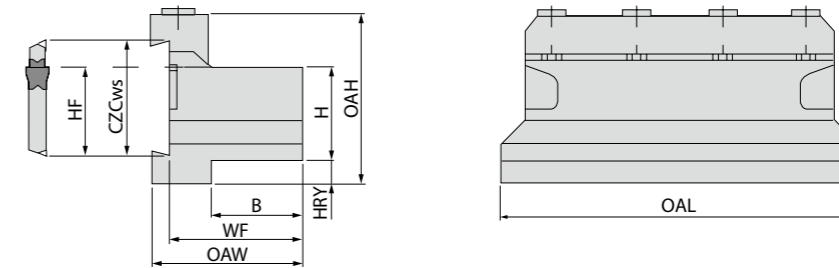

: p. 119 Unit:mm

Designation	EDP 5700..	CZCws	H	B	HF	WF	HRY	OAL	OAH	OAW
YGBU 20 - 32	0060	32	20	19	25	32.7	13	100	50	38
YGBU 25 - 32	0061	32	25	23	25	36.7	8	110	50	42
YGBU 32 - 32	0062	32	32	29	25	42.7	5	110	54	48
YGBU 20 - 32 - C	● 0228	32	20	19	25	32.7	13	100	50	38
YGBU 25 - 32 - C	● 0229	32	25	23	25	36.7	8	110	50	42
YGBU 32 - 32 - C	● 0230	32	32	29	25	42.7	5	110	54	48

Series	Designation	Infomation	Screw	Ring	Wrench
YGBU	20-32	Description	YABK-03	Y2505-M6X30	YAAL-07-5
		EDP	18000204	18000199	18000203
	25~32-32	Description	YABK-04	Y2505-M6X30	YAAL-07-5
		EDP	18000205	18000199	18000203

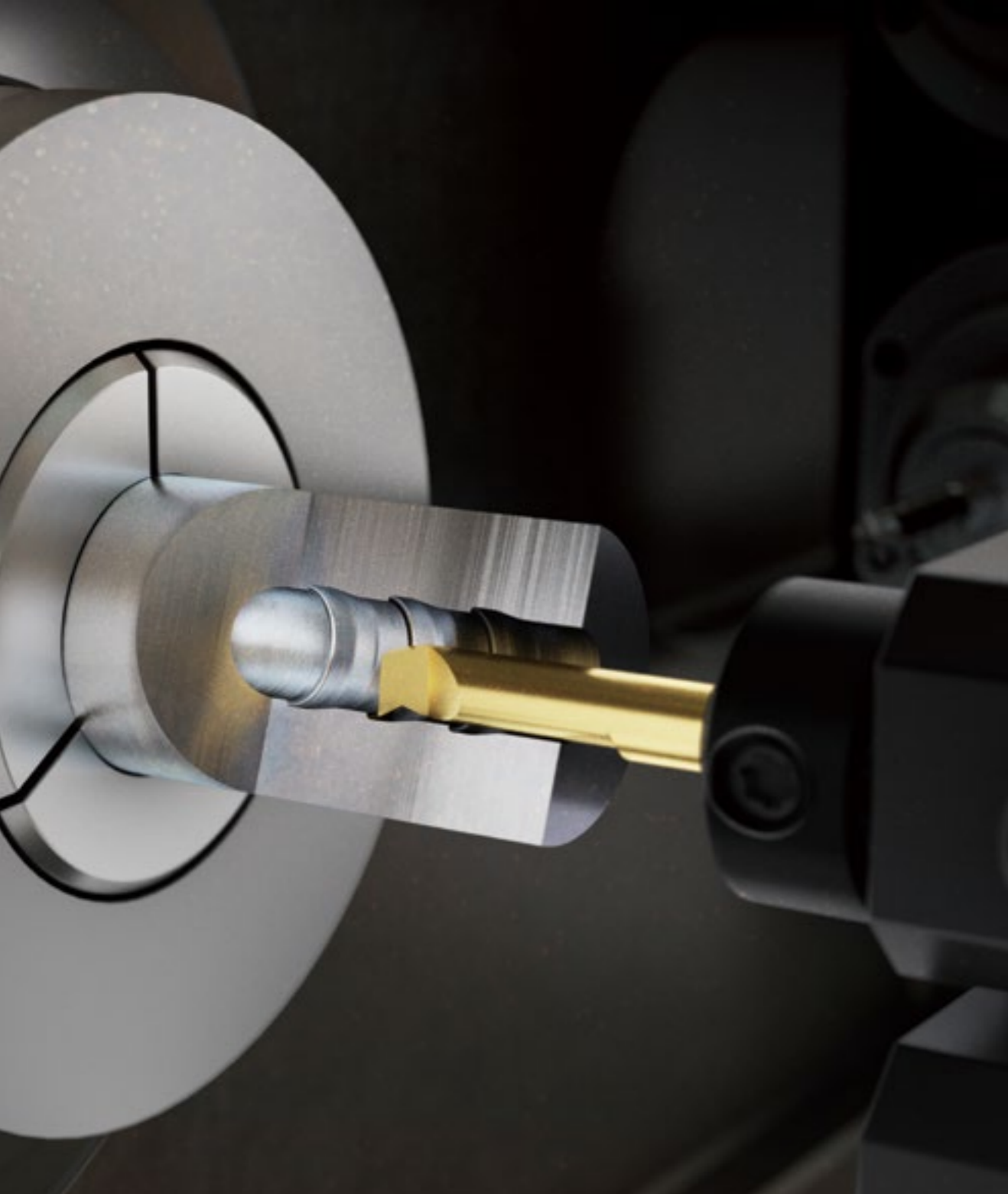

SOLID MINIATURE TURNING for SMALL BORE NEW



Scan this QR code to see our Nanocut at work.

Code Keys - Boring Tool & Holder

Boring Tool

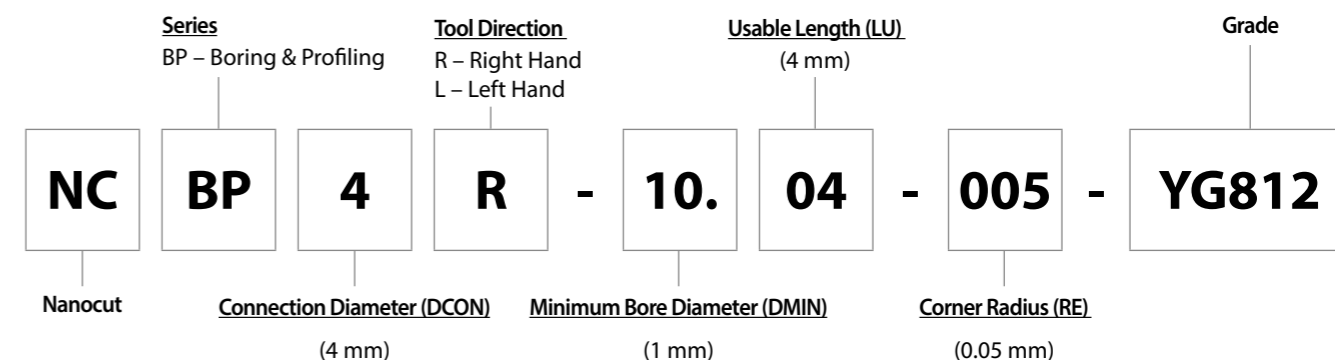

Holder

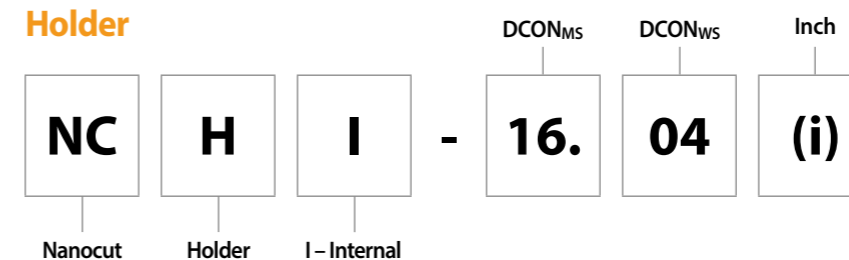

Success Story

Cutting Conditions

Size	Ø 6 mm, R 0.2 mm
Work Material	SCM440 (HRc 20)
Cutting Speed	100 m/min.
RPM	637 rev./min.
Feed per Revolution	0.1 mm/rev.
Boring Depth	Axial: 10 mm Radial: 0.15 mm
Coolant	Wet Cut
Operation	Boring
Machine	Turn Mill

Less is better

YG 55 μm

43 μm

Edge wear (after 30 min.)

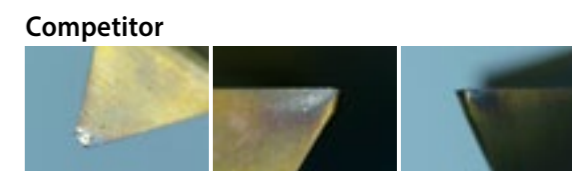
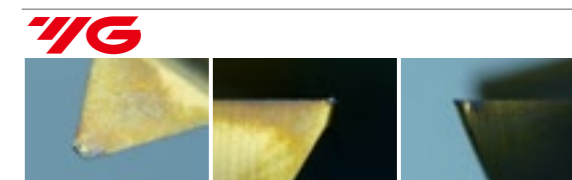

Overview

At present, as demand for small parts (camera lens, mobile phone parts) and medical instruments (implants) increases, demand for small-diameter products capable of high-precision processing is increasing.

Application

- Turning of Small Bore Components
- Internal Turning(Boring), Grooving and Threading

Features

- Minimum Diameter(Boring & Profiling series) : Ø 1 mm
- Internal Coolant for Longer Tool life and Enhanced Chip Evacuation
- Secure Connection Design: Pin + Slant Positioning
- 10 Geometries for Various Applications

Benefits

- Reduced Machine Down Time
- Lower Machining Cost

YG812 - Micro Grain Carbide Grade

P10 - P20 **M20 - M30** Submicron Grade Carbide Substrate Material for high toughness
K20 - K30 **S10 - S25** and wear resistance realizes high precision machining

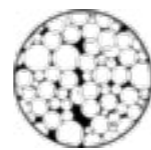

Advantages of Nanocut

Easy Clamping
Secure and Simple system for fast change and fast locking

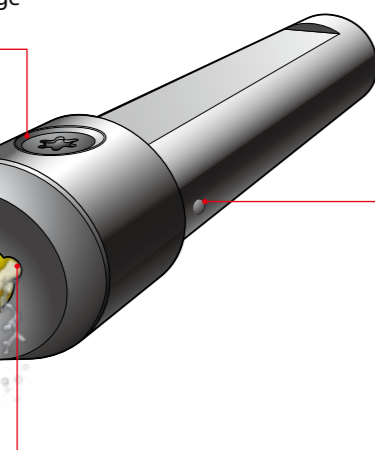

Internal Coolant
Helps chip evacuation and improves tool life

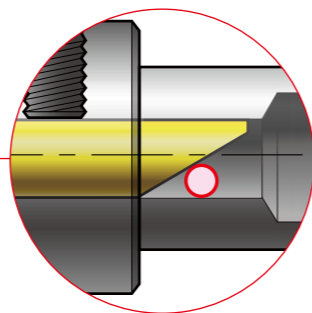

Secure Slant Connection
Ensures High repeatability for height and axial position



Click/Touch each page number and move to the very page!

Overview

Recommended Cutting Conditions : p.223

Series	KAPR (°)	DCON (mm)	Page
BP Boring & Profiling	98	4,6	132
BO Boring with Chipbreaker	98		133
BF 90° Boring	90		134
PR Profiling	98		135

Series	CW (mm)	DCON (mm)	Page
GR Grooving Round	1.00 - 2.00	4,6	136
GS Grooving Square	0.79 - 2.00		137
FI Face Grooving Internal	1.00 - 3.00		138
FE Face Grooving External	1.00 - 3.00		138

Series	WF (mm)	DCON (mm)	Page
CH Chamfering	0.50 - 1.10	4,6	139
TH Threading	2.00 - 2.95		140

Series	DCON _{WS} (mm)	DCON _{MS} (mm)	Page
Holder	4,6	12-25	141

Boring Tool
BP - Boring & Profiling NEW

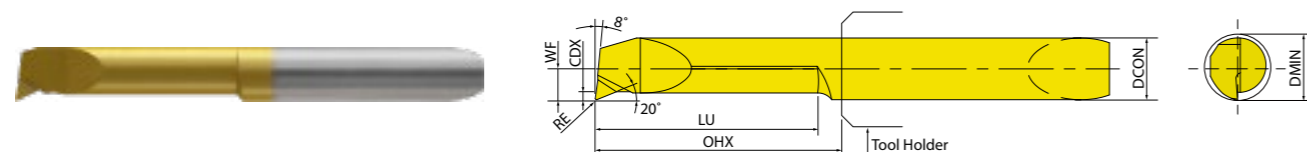

●: Stock item
○: Order made item

KAPR	DCON (mm)	Designation	EDP	Metric (mm)							YG812
				DMIN	LU	RE	CDX	WF	OHX	OAL	
4	98°	NCBP4R-10.04-005-YG812	NCBP04R1004005T	1	4	0.05	0.1	0.45	13	28	●
		NCBP4R-10.04-010-YG812	NCBP04R1004010T	1	4	0.10	0.1	0.45	13	28	●
		NCBP4R-10.06-005-YG812	NCBP04R1006005T	1	6	0.05	0.1	0.45	13	28	●
		NCBP4R-10.06-010-YG812	NCBP04R1006010T	1	6	0.10	0.1	0.45	13	28	●
		NCBP4R-17.06-005-YG812	NCBP04R1706005T	1.7	6	0.05	0.2	0.7	13	28	○
		NCBP4R-17.06-010-YG812	NCBP04R1706010T	1.7	6	0.10	0.2	0.7	13	28	●
		NCBP4R-17.09-005-YG812	NCBP04R1709005T	1.7	9	0.05	0.2	0.7	13	28	○
		NCBP4R-17.09-010-YG812	NCBP04R1709010T	1.7	9	0.10	0.2	0.7	13	28	●
		NCBP4R-22.06-005-YG812	NCBP04R2206005T	2.2	6	0.05	0.2	0.95	13	28	○
		NCBP4R-22.06-010-YG812	NCBP04R2206010T	2.2	6	0.10	0.2	0.95	13	28	●
		NCBP4R-22.09-005-YG812	NCBP04R2209005T	2.2	9	0.05	0.2	0.95	13	28	○
		NCBP4R-22.09-010-YG812	NCBP04R2209010T	2.2	9	0.10	0.2	0.95	13	28	●
		NCBP4R-22.13-010-YG812	NCBP04R2213010T	2.2	13	0.10	0.2	0.95	18	33	●
		NCBP4R-27.10-005-YG812	NCBP04R2710005T	2.7	10	0.05	0.2	1.2	13	28	○
		NCBP4R-27.10-015-YG812	NCBP04R2710015T	2.7	10	0.15	0.2	1.2	13	28	●
		NCBP4R-27.15-005-YG812	NCBP04R2715005T	2.7	15	0.05	0.2	1.2	18	33	○
		NCBP4R-27.15-015-YG812	NCBP04R2715015T	2.7	15	0.15	0.2	1.2	18	33	●
		NCBP4R-32.10-015-YG812	NCBP04R3210015T	3.2	10	0.15	0.2	1.45	13	28	●
		NCBP4R-32.15-015-YG812	NCBP04R3215015T	3.2	15	0.15	0.2	1.45	18	33	●
		NCBP4R-32.20-005-YG812	NCBP04R3220005T	3.2	20	0.05	0.2	1.45	23	38	○
NCBP4R-32.20-015-YG812	NCBP04R3220015T	3.2	20	0.15	0.2	1.45	23	38	●		
NCBP4R-42.10-015-YG812	NCBP04R4210015T	4.2	10	0.15	0.3	1.95	13	28	●		
NCBP4R-42.15-005-YG812	NCBP04R4215005T	4.2	15	0.05	0.3	1.95	18	33	○		
NCBP4R-42.15-015-YG812	NCBP04R4215015T	4.2	15	0.15	0.3	1.95	18	33	●		
NCBP4R-42.20-005-YG812	NCBP04R4220005T	4.2	20	0.05	0.3	1.95	23	38	○		
NCBP4R-42.20-015-YG812	NCBP04R4220015T	4.2	20	0.15	0.3	1.95	23	38	●		
NCBP4R-42.25-005-YG812	NCBP04R4225005T	4.2	25	0.05	0.3	1.95	28	43	○		
NCBP4R-42.25-015-YG812	NCBP04R4225015T	4.2	25	0.15	0.3	1.95	28	43	●		
6	98°	NCBP6R-62.15-020-YG812	NCBP06R6215020T	6.2	15	0.20	0.5	2.95	20.5	43	●
		NCBP6R-62.20-020-YG812	NCBP06R6220020T	6.2	20	0.20	0.5	2.95	25.5	48	●
		NCBP6R-62.25-020-YG812	NCBP06R6225020T	6.2	25	0.20	0.5	2.95	30.5	53	●
		NCBP6R-62.30-020-YG812	NCBP06R6230020T	6.2	30	0.20	0.5	2.95	35.5	58	●
		NCBP6R-62.35-020-YG812	NCBP06R6235020T	6.2	35	0.20	0.5	2.95	40.5	63	●
		NCBP6R-62.40-020-YG812	NCBP06R6240020T	6.2	40	0.20	0.5	2.95	45.5	68	●

Boring Tool
BO - Boring with Chip Breaker NEW

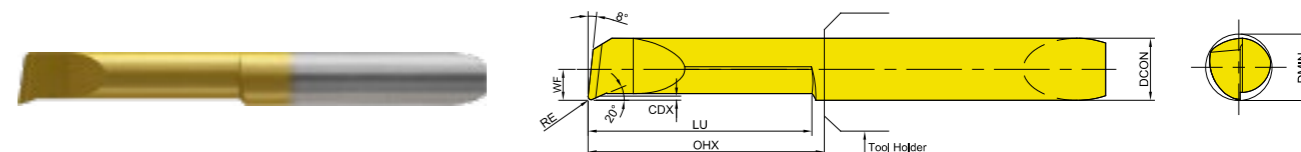

●: Stock item
○: Order made item

KAPR	DCON (mm)	Designation	EDP	Metric (mm)							YG812		
				DMIN	LU	RE	CDX	WF	OHX	OAL			
4	98°	NCBO4R-10.06-005-YG812	NCBO04R1006005T	1	6	0.05	0.1	0.45	13	28	○		
		NCBO4R-10.06-010-YG812	NCBO04R1006010T	1	6	0.10	0.1	0.45	13	28	●		
		NCBO4R-17.09-005-YG812	NCBO04R1709005T	1.7	9	0.05	0.2	0.7	13	28	○		
		NCBO4R-17.09-010-YG812	NCBO04R1709010T	1.7	9	0.10	0.2	0.7	13	28	○		
		NCBO4R-22.09-005-YG812	NCBO04R2209005T	2.2	9	0.05	0.2	0.95	13	28	○		
		NCBO4R-22.09-010-YG812	NCBO04R2209010T	2.2	9	0.10	0.2	0.95	13	28	●		
		NCBO4R-22.13-010-YG812	NCBO04R2213010T	2.2	13	0.10	0.2	0.95	18	33	○		
		NCBO4R-27.15-005-YG812	NCBO04R2715005T	2.7	15	0.05	0.2	1.2	18	33	○		
		NCBO4R-27.15-015-YG812	NCBO04R2715015T	2.7	15	0.15	0.2	1.2	18	33	○		
		NCBO4R-32.15-015-YG812	NCBO04R3215015T	3.2	15	0.15	0.2	1.45	18	33	●		
		NCBO4R-32.20-005-YG812	NCBO04R3220005T	3.2	20	0.05	0.2	1.45	23	38	○		
		NCBO4R-32.20-015-YG812	NCBO04R3220015T	3.2	20	0.15	0.2	1.45	23	38	●		
		NCBO4R-42.20-005-YG812	NCBO04R4220005T	4.2	20	0.05	0.3	1.95	23	38	○		
		NCBO4R-42.20-015-YG812	NCBO04R4220015T	4.2	20	0.15	0.3	1.95	23	38	●		
		NCBO4R-42.25-005-YG812	NCBO04R4225005T	4.2	25	0.05	0.3	1.95	28	43	○		
		NCBO4R-42.25-015-YG812	NCBO04R4225015T	4.2	25	0.15	0.3	1.95	28	43	●		
		6	98°	NCBO6R-62.15-020-YG812	NCBO06R6215020T	6.2	15	0.20	0.5	2.95	20.5	43	●
				NCBO6R-62.25-020-YG812	NCBO06R6225020T	6.2	25	0.20	0.5	2.95	30.5	53	●
				NCBO6R-62.30-020-YG812	NCBO06R6230020T	6.2	30	0.20	0.5	2.95	35.5	58	●
				NCBO6R-62.35-020-YG812	NCBO06R6235020T	6.2	35	0.20	0.5	2.95	40.5	63	●
NCBO6R-62.40-020-YG812	NCBO06R6240020T			6.2	40	0.20	0.5	2.95	45.5	68	○		

Boring Tool
BF - 90° Boring NEW

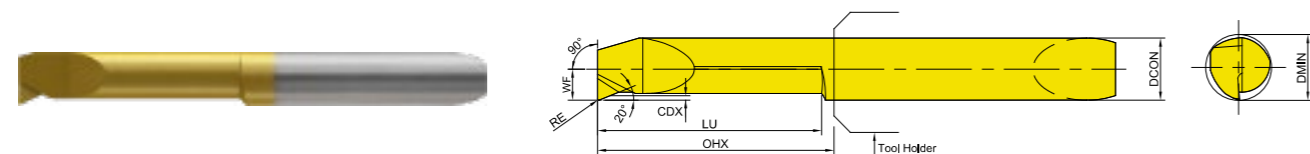

●: Stock item
○: Order made item

KAPR	DCON (mm)	Designation	EDP	Metric (mm)							YG812
				DMIN	LU	RE	CDX	WF	OHX	OAL	
4	90°	NCBF4R-10.04-010-YG812	NCBF04R1004010T	1	4	0.10	0.1	0.45	13	28	○
		NCBF4R-10.06-010-YG812	NCBF04R1006010T	1	6	0.10	0.1	0.45	13	28	○
		NCBF4R-17.06-010-YG812	NCBF04R1706010T	1.7	6	0.10	0.2	0.7	13	28	○
		NCBF4R-17.09-010-YG812	NCBF04R1709010T	1.7	9	0.10	0.2	0.7	13	28	○
		NCBF4R-22.06-010-YG812	NCBF04R2206010T	2.2	6	0.10	0.2	0.95	13	28	○
		NCBF4R-22.09-010-YG812	NCBF04R2209010T	2.2	9	0.10	0.2	0.95	13	28	○
		NCBF4R-22.13-010-YG812	NCBF04R2213010T	2.2	13	0.10	0.2	0.95	18	33	○
		NCBF4R-27.10-015-YG812	NCBF04R2710015T	2.7	10	0.15	0.2	1.2	13	28	○
		NCBF4R-27.15-015-YG812	NCBF04R2715015T	2.7	15	0.15	0.2	1.2	18	33	○
		NCBF4R-32.10-015-YG812	NCBF04R3210015T	3.2	10	0.15	0.2	1.45	13	28	○
		NCBF4R-32.15-015-YG812	NCBF04R3215015T	3.2	15	0.15	0.2	1.45	18	33	○
		NCBF4R-32.20-015-YG812	NCBF04R3220015T	3.2	20	0.15	0.2	1.45	23	38	○
		NCBF4R-42.10-015-YG812	NCBF04R4210015T	4.2	10	0.15	0.3	1.95	13	28	○
		NCBF4R-42.15-015-YG812	NCBF04R4215015T	4.2	15	0.15	0.3	1.95	18	33	○
		NCBF4R-42.20-015-YG812	NCBF04R4220015T	4.2	20	0.15	0.3	1.95	23	38	○
		NCBF4R-42.25-015-YG812	NCBF04R4225015T	4.2	25	0.15	0.3	1.95	28	43	○
6	90°	NCBF6R-62.15-020-YG812	NCBF06R6215020T	6.2	15	0.20	0.5	2.95	20.5	43	○
		NCBF6R-62.20-020-YG812	NCBF06R6220020T	6.2	20	0.20	0.5	2.95	25.5	48	○
		NCBF6R-62.25-020-YG812	NCBF06R6225020T	6.2	25	0.20	0.5	2.95	30.5	53	○
		NCBF6R-62.30-020-YG812	NCBF06R6230020T	6.2	30	0.20	0.5	2.95	35.5	58	○
		NCBF6R-62.35-020-YG812	NCBF06R6235020T	6.2	35	0.20	0.5	2.95	40.5	63	○
		NCBF6R-62.40-020-YG812	NCBF06R6240020T	6.2	40	0.20	0.5	2.95	45.5	68	○

Boring Tool
PR - Profiling NEW

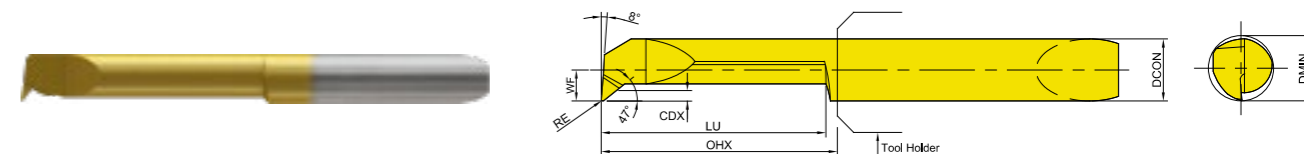

●: Stock item
○: Order made item

KAPR	DCON (mm)	Designation	EDP	Metric (mm)							YG812
				DMIN	LU	RE	CDX	WF	OHX	OAL	
4	98°	NCPR4R-10.04-010-YG812	NCPR04R1004010T	1	4	0.10	0.1	0.45	13	28	○
		NCPR4R-10.06-010-YG812	NCPR04R1006010T	1	6	0.10	0.1	0.45	13	28	○
		NCPR4R-17.06-010-YG812	NCPR04R1706010T	1.7	6	0.10	0.2	0.7	13	28	○
		NCPR4R-17.09-010-YG812	NCPR04R1709010T	1.7	9	0.10	0.2	0.7	13	28	○
		NCPR4R-22.06-010-YG812	NCPR04R2206010T	2.2	6	0.10	0.2	0.95	13	28	○
		NCPR4R-22.09-010-YG812	NCPR04R2209010T	2.2	9	0.10	0.2	0.95	13	28	○
		NCPR4R-22.13-010-YG812	NCPR04R2213010T	2.2	13	0.10	0.2	0.95	18	33	○
		NCPR4R-27.10-015-YG812	NCPR04R2710015T	2.7	10	0.15	0.2	1.2	13	28	○
		NCPR4R-27.15-015-YG812	NCPR04R2715015T	2.7	15	0.15	0.2	1.2	18	33	○
		NCPR4R-32.10-015-YG812	NCPR04R3210015T	3.2	10	0.15	0.2	1.45	13	28	○
		NCPR4R-32.15-015-YG812	NCPR04R3215015T	3.2	15	0.15	0.2	1.45	18	33	○
		NCPR4R-32.20-015-YG812	NCPR04R3220015T	3.2	20	0.15	0.2	1.45	23	38	○
		NCPR4R-42.10-015-YG812	NCPR04R4210015T	4.2	10	0.15	0.3	1.95	13	28	●
		NCPR4R-42.15-015-YG812	NCPR04R4215015T	4.2	15	0.15	0.3	1.95	18	33	●
		NCPR4R-42.20-015-YG812	NCPR04R4220015T	4.2	20	0.15	0.3	1.95	23	38	●
		NCPR4R-42.25-015-YG812	NCPR04R4225015T	4.2	25	0.15	0.3	1.95	28	43	○
6	98°	NCPR6R-62.15-020-YG812	NCPR06R6215020T	6.2	15	0.20	0.5	2.95	20.5	43	●
		NCPR6R-62.20-020-YG812	NCPR06R6220020T	6.2	20	0.20	0.5	2.95	25.5	48	●
		NCPR6R-62.25-020-YG812	NCPR06R6225020T	6.2	25	0.20	0.5	2.95	30.5	53	○
		NCPR6R-62.30-015-YG812	NCPR06R6230015T	6.2	30	0.15	0.5	2.95	35.5	58	●
		NCPR6R-62.30-020-YG812	NCPR06R6230020T	6.2	30	0.20	0.5	2.95	35.5	58	○
		NCPR6R-62.35-020-YG812	NCPR06R6235020T	6.2	35	0.20	0.5	2.95	40.5	63	○
NCPR6R-62.40-020-YG812	NCPR06R6240020T	6.2	40	0.20	0.5	2.95	45.5	68	○		

Boring Tool
GR - Grooving Round NEW

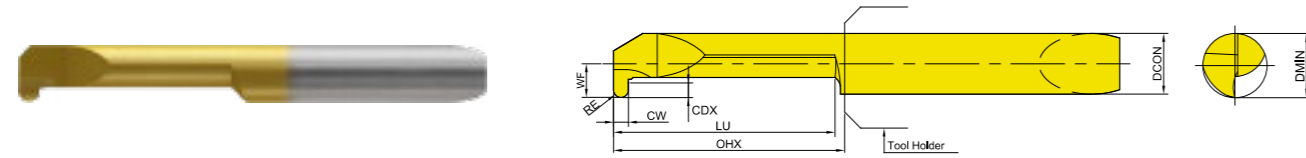

●: Stock item
○: Order made item

DCON (mm)	Designation	EDP	Metric (mm)									YG812
			DMIN	LU	RE	CW	CDX	WF	OHX	OAL		
4	NCGR4R - 42.15 - 10x08 - YG812	NCGR04R4215100T	4.2	15	0.5	1.0	0.8	1.95	18	33	○	
	NCGR4R - 42.15 - 12x08 - YG812	NCGR04R4215120T	4.2	15	0.58	1.2	0.8	1.95	18	33	○	
	NCGR4R - 42.15 - 15x08 - YG812	NCGR04R4215150T	4.2	15	0.75	1.5	1	1.95	18	33	○	
	NCGR4R - 42.15 - 16x08 - YG812	NCGR04R4215160T	4.2	15	0.81	1.6	1	1.95	18	33	○	
6	NCGR6R - 62.25 - 10x18 - YG812	NCGR06R6225100T	6.2	25	0.5	1.0	1.8	2.95	30.5	53	○	
	NCGR6R - 62.25 - 15x18 - YG812	NCGR06R6225150T	6.2	25	0.75	1.5	1.8	2.95	30.5	53	○	
	NCGR6R - 62.25 - 16x18 - YG812	NCGR06R6225160T	6.2	25	0.81	1.6	1.8	2.95	30.5	53	○	
	NCGR6R - 62.25 - 20x18 - YG812	NCGR06R6225200T	6.2	25	1	2.0	1.8	2.95	30.5	53	○	

Boring Tool
GS - Grooving Square NEW

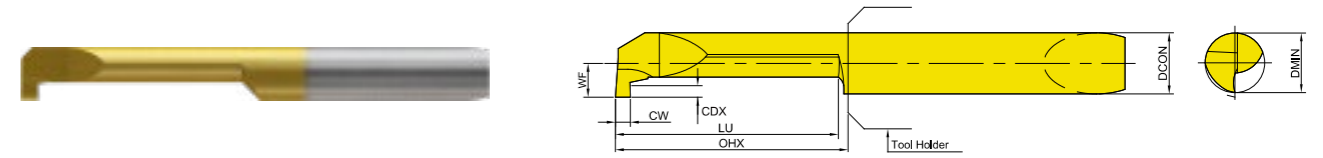

●: Stock item
○: Order made item

DCON (mm)	Designation	EDP	Metric (mm)									YG812
			DMIN	LU	CW	CDX	WF	OHX	OAL			
4	NCGS4R - 42.10 - 079x08 - YG812	NCGS04R4210079T	4.2	10	0.79	0.8	1.95	13	38	○		
	NCGS4R - 42.15 - 079x08 - YG812	NCGS04R4215079T	4.2	15	0.79	0.8	1.95	18	43	○		
	NCGS4R - 42.20 - 079x08 - YG812	NCGS04R4220079T	4.2	20	0.79	0.8	1.95	23	48	○		
	NCGS4R - 42.10 - 100x08 - YG812	NCGS04R4210100T	4.2	10	1.00	0.8	1.95	13	38	●		
6	NCGS4R - 42.15 - 100x08 - YG812	NCGS04R4215100T	4.2	15	1.00	0.8	1.95	18	43	●		
	NCGS4R - 42.20 - 100x08 - YG812	NCGS04R4220100T	4.2	20	1.00	0.8	1.95	23	48	○		
	NCGS6R - 62.10 - 079x18 - YG812	NCGS06R6210079T	6.2	10	0.79	1.8	2.95	15.5	38	○		
	NCGS6R - 62.15 - 079x18 - YG812	NCGS06R6215079T	6.2	15	0.79	1.8	2.95	20.5	43	○		
	NCGS6R - 62.25 - 079x18 - YG812	NCGS06R6225079T	6.2	25	0.79	1.8	2.95	30.5	53	○		
	NCGS6R - 62.35 - 079x18 - YG812	NCGS06R6235079T	6.2	35	0.79	1.8	2.95	40.5	63	○		
	NCGS6R - 62.10 - 100x18 - YG812	NCGS06R6210100T	6.2	10	1.00	1.8	2.95	15.5	38	○		
	NCGS6R - 62.15 - 100x18 - YG812	NCGS06R6215100T	6.2	15	1.00	1.8	2.95	20.5	43	●		
	NCGS6R - 62.25 - 100x18 - YG812	NCGS06R6225100T	6.2	25	1.00	1.8	2.95	30.5	53	●		
	NCGS6R - 62.35 - 100x18 - YG812	NCGS06R6235100T	6.2	35	1.00	1.8	2.95	40.5	63	○		
	NCGS6R - 62.10 - 117x18 - YG812	NCGS06R6210117T	6.2	10	1.17	1.8	2.95	15.5	38	○		
	NCGS6R - 62.15 - 117x18 - YG812	NCGS06R6215117T	6.2	15	1.17	1.8	2.95	20.5	43	○		
	NCGS6R - 62.25 - 117x18 - YG812	NCGS06R6225117T	6.2	25	1.17	1.8	2.95	30.5	53	○		
	NCGS6R - 62.35 - 117x18 - YG812	NCGS06R6235117T	6.2	35	1.17	1.8	2.95	40.5	63	○		
	NCGS6R - 62.10 - 150x18 - YG812	NCGS06R6210150T	6.2	10	1.50	1.8	2.95	15.5	38	●		
	NCGS6R - 62.15 - 150x18 - YG812	NCGS06R6215150T	6.2	15	1.50	1.8	2.95	20.5	43	●		
	NCGS6R - 62.25 - 150x18 - YG812	NCGS06R6225150T	6.2	25	1.50	1.8	2.95	30.5	53	●		
	NCGS6R - 62.35 - 150x18 - YG812	NCGS06R6235150T	6.2	35	1.50	1.8	2.95	40.5	63	○		
	NCGS6R - 62.10 - 157x18 - YG812	NCGS06R6210157T	6.2	10	1.57	1.8	2.95	15.5	38	○		
	NCGS6R - 62.15 - 157x18 - YG812	NCGS06R6215157T	6.2	15	1.57	1.8	2.95	20.5	43	○		
NCGS6R - 62.25 - 157x18 - YG812	NCGS06R6225157T	6.2	25	1.57	1.8	2.95	30.5	53	○			
NCGS6R - 62.35 - 157x18 - YG812	NCGS06R6235157T	6.2	35	1.57	1.8	2.95	40.5	63	○			
NCGS6R - 62.10 - 198x18 - YG812	NCGS06R6210198T	6.2	10	1.98	1.8	2.95	15.5	38	○			
NCGS6R - 62.15 - 198x18 - YG812	NCGS06R6215198T	6.2	15	1.98	1.8	2.95	20.5	43	○			
NCGS6R - 62.25 - 198x18 - YG812	NCGS06R6225198T	6.2	25	1.98	1.8	2.95	30.5	53	○			
NCGS6R - 62.30 - 198x18 - YG812	NCGS06R6230198T	6.2	30	1.98	1.8	2.95	35.5	58	○			
NCGS6R - 62.10 - 200x18 - YG812	NCGS06R6210200T	6.2	10	2.00	1.8	2.95	15.5	38	●			
NCGS6R - 62.15 - 200x18 - YG812	NCGS06R6215200T	6.2	15	2.00	1.8	2.95	20.5	43	●			
NCGS6R - 62.25 - 200x18 - YG812	NCGS06R6225200T	6.2	25	2.00	1.8	2.95	30.5	53	●			

Boring Tool
FI - Face Grooving Internal

NEW

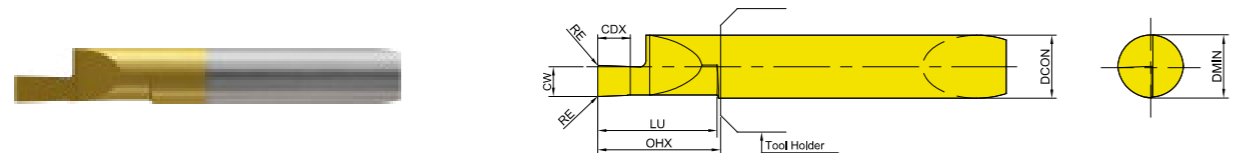

●: Stock item
○: Order made item

DCON (mm)	Designation	EDP	Metric (mm)								YG812
			DMIN	LU	RE	CW	CDX	WF	OHX	OAL	
6	NCFI6R-62.15-10x20-YG812	NCFI06R6215010T	6.2	15	0.1	1.0	2.0	2.95	20.5	43	●
	NCFI6R-62.15-15x30-YG812	NCFI06R6215015T	6.2	15	0.1	1.5	3.0	2.95	20.5	43	●
	NCFI6R-62.15-20x40-YG812	NCFI06R6215020T	6.2	15	0.1	2.0	4.0	2.95	20.5	43	●
	NCFI6R-62.15-25x50-YG812	NCFI06R6215025T	6.2	15	0.1	2.5	5.0	2.95	20.5	43	●
	NCFI6R-62.15-30x60-YG812	NCFI06R6215030T	6.2	15	0.1	3.0	6.0	2.95	20.5	43	●

Boring Tool
CH - Chamfering

NEW

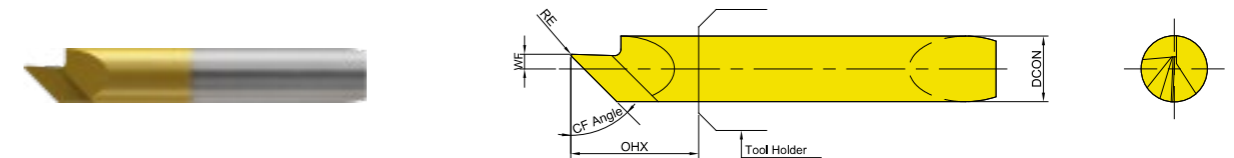

●: Stock item
○: Order made item

KAPR	DCON (mm)	Designation	EDP	Metric (mm)						YG812
				DMIN	RE	CDX	WF	OHX	OAL	
45°	6	NCCH6R-10.03-45-YG812	NCCH06R103045T	1.0	0.2	3.5	1.1	15.5	38	○
60°		NCCH6R-10.04-60-YG812	NCCH06R103060T	1.0	0.2	4	0.5	15.5	38	○

Boring Tool
FE - Face Grooving External

NEW

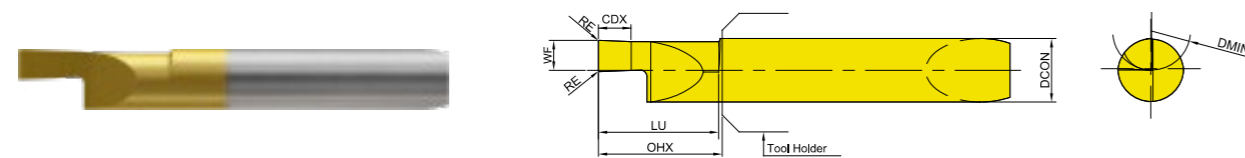

●: Stock item
○: Order made item

DCON (mm)	Designation	EDP	Metric (mm)								YG812
			DMIN	LU	RE	CW	CDX	WF	OHX	OAL	
6	NCFE6R-62.15-10x20-YG812	NCFE06R6215010T	6.2	15	0.1	1.0	2.0	2.95	20.5	43	●
	NCFE6R-62.15-15x30-YG812	NCFE06R6215015T	6.2	15	0.1	1.5	3.0	2.95	20.5	43	●
	NCFE6R-62.15-20x40-YG812	NCFE06R6215020T	6.2	15	0.1	2.0	4.0	2.95	20.5	43	●
	NCFE6R-62.15-25x50-YG812	NCFE06R6215025T	6.2	15	0.1	2.5	5.0	2.95	20.5	43	●
	NCFE6R-62.15-30x60-YG812	NCFE06R6215030T	6.2	15	0.1	3.0	6.0	2.95	20.5	43	●

Boring Tool
TH - Threading NEW

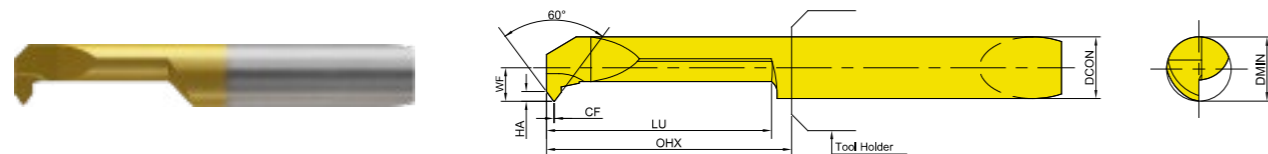

* P-60 : Partial Profile, 60°

DCON (mm)	Designation	EDP	Metric (mm)										YG812
			DMIN	LU	TPN	TPX	WF	HA	CF	OHX	OAL		
4	NCTH04R-42.15-050-P-60-YG812	NCTV04R4215050T	4.2	15	0.50	0.70	2	0.45	0.06	18	33	○	
	NCTH04R-42.15-075-P-60-YG812	NCTV04R4215075T	4.2	15	0.75	1.00	2.35	0.65	0.09	18	33	○	
	NCTH04R-42.15-100-P-60-YG812	NCTV04R4215100T	4.2	15	1.00	1.25	2.25	0.8	0.12	18	33	○	
6	NCTH06R-62.15-100-P-60-YG812	NCTV06R6215100T	6.2	15	1.00	1.25	2.95	0.8	0.12	20.5	43	○	
	NCTH06R-62.15-125-P-60-YG812	NCTV06R6215125T	6.2	15	1.25	1.50	2.3	0.97	0.15	20.5	43	○	
	NCTH06R-62.15-150-P-60-YG812	NCTV06R6215150T	6.2	15	1.50	1.75	2.95	1.14	0.18	20.5	43	○	

Boring ToolHolder
Holder NEW

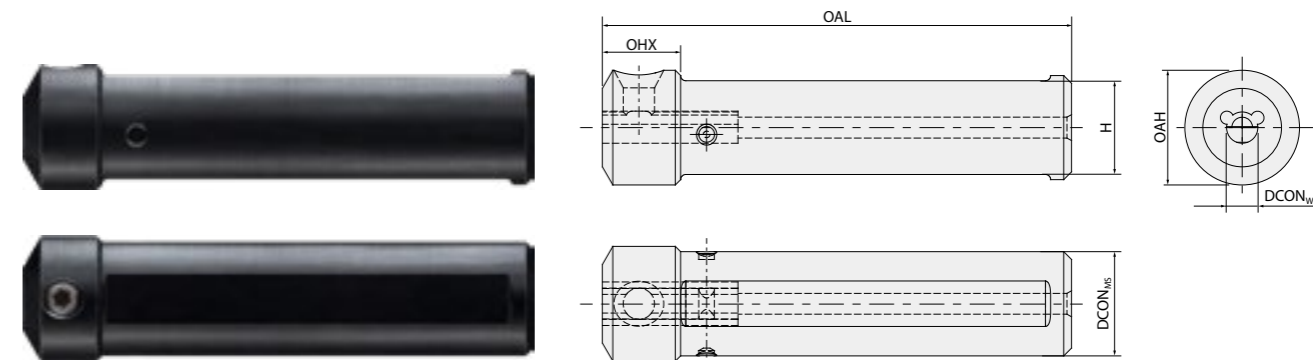

Scale	Insert Size (DCON _{ms})	Designation	EDP	DCON _{ms}	OAL	H	OAH	OHX
Metric (mm)	4	NCHI-12.4	ZBR0400012	12	70	10	15.5	14
		NCHI-16.4	ZBR0400016	16	75	14	17.5	
		NCHI-20.4	ZBR0400020	20	90	18	20	
		NCHI-22.4	ZBR0400022	22	110	20	22	
	6	NCHI-12.6	ZBR0600012	12	70	10	16.5	
		NCHI-16.6	ZBR0600016	16	75	14	18.5	
		NCHI-20.6	ZBR0600020	20	90	18	22	
		NCHI-22.6	ZBR0600022	22	110	20	22	
		NCHI-25.6	ZBR0600025	25	110	23	25	

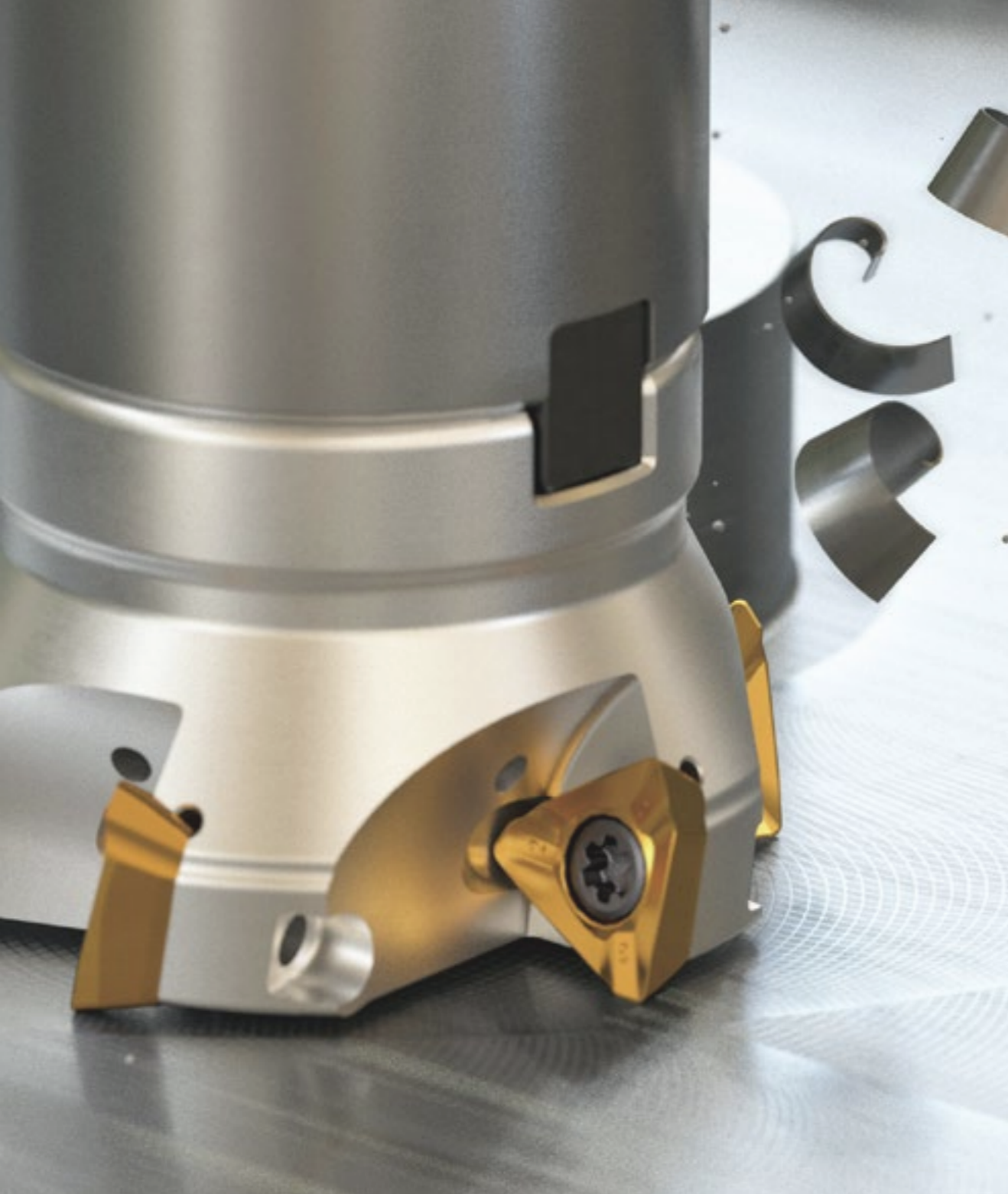

MILLING

Product Overview
 Application Guide
 Milling Inserts & Cutter Overview
 Milling Inserts & Cutter



Scan this QR code to see our YG SM3 Mill at work.



Scan this QR code to see our YG HF4 Mill at work.

Code Keys - Milling Cutters

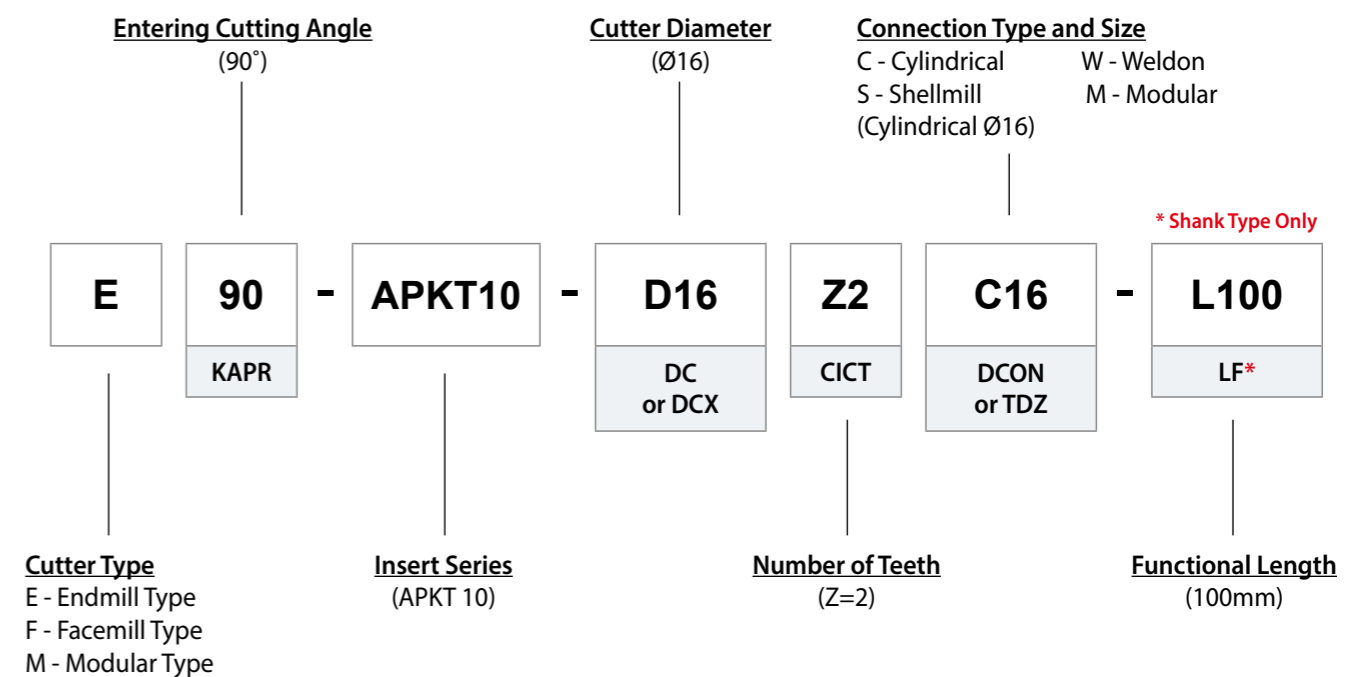
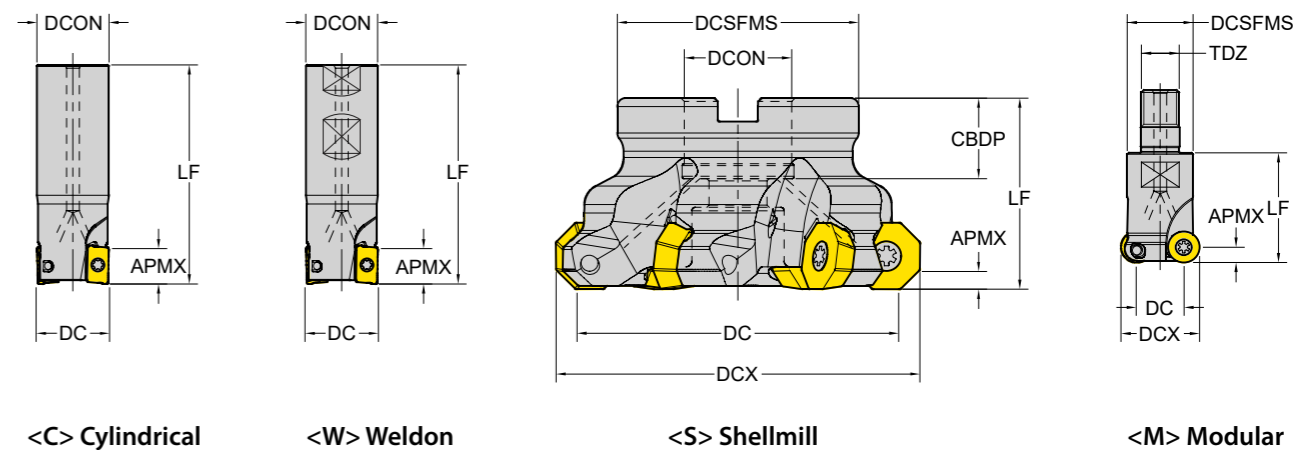









Milling - Code System



Insert ISO Code System

1	2	3	4	5	6	7
A	P	K	T	16	04	08
Shape	Relief Angle (AN)	Tolerance	Clamping & Chipbreaker	Insert Size	Insert Thickness (S)	Corner Radius

1 - Shape

Symbol	Shape	
H	Hexagonal	
O	Octagonal	
P	Pentagonal	
S	Square	
T	Triangular	
W	Trigon	
L	Rectangular	
A	Parallelogram 80°	
R	Round	

2 - Relief Angle (AN)

Symbol	Relief Angle (AN)	
N	No Relief Angle	
B	Relief 5°	
C	Relief 7°	
P	Relief 11°	
D	Relief 15°	
E	Relief 20°	
F	Relief 25°	
O	Special	

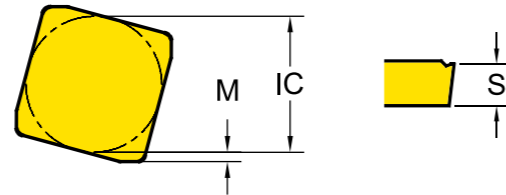







3 - Tolerance Class

Symbol	Inner Circle IC (mm)	Nose Height M (mm)	Thickness S (mm)
C	± 0.025	± 0.013	± 0.025
E	± 0.025	± 0.025	± 0.025
G	± 0.025	± 0.025	± 0.13
H	± 0.013	± 0.013	± 0.025
K*	± 0.05~0.15*	± 0.013	± 0.025
M*	± 0.05~0.15*	± 0.08~0.2*	± 0.13
U*	± 0.08~0.25*	± 0.13~0.38*	± 0.13

*Tolerance is different by insert IC size. Please see ISO 1832

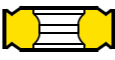
4 - Clamping & Chipbreaker

Symbol	Clamping	Chipbreaker	Figure
N	No clamping hole	X	
R		One Face	
W	Screw Hole	X	
T		One Face	
U		Both Faces	
X		Special	

5 - Insert Size

* No Standard for milling insert size

6 - Insert Thickness

* No Standard for milling insert thickness

Milling - Code System

Insert ISO Code System

8	9	10
PDTR	-TR	YG602
Corner Geometry	Chipbreaker	Grade

7 - Corner Radius (RE)

Symbol	Corner Radius - RE(mm)	Symbol	Corner Radius - RE(mm)
04	0.4	16	1.6
08	0.8	20	2.0
12	1.2	24	2.4

8 - Corner Geometry

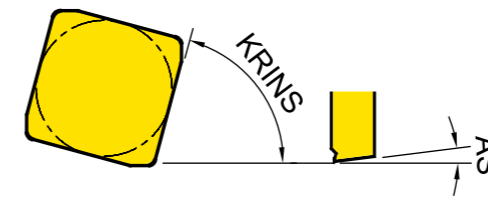

8-1	8-2	8-3	8-4
P	D	T	R
Cutting Edge Angle (KRINS)	Wiper Edge Clearance (AS)	Edge Condition	Feed Direction

*Refer to page. 147 for -AL, -ST, -TR... types





8-1 - Cutting Edge Angle (KRINS)

Symbol	Cutting Edge Angle (KRINS)
P	90°
A	45°
D	60°
E	75°
F	85°
Z	Special



8-2 - Wiper Edge Clearance (AS)

Symbol	Wiper Edge Clearance (AS)
N	0°
P	11°
D	15°
E	20°
F	25°
Z	Special

8-3 - Edge Condition

Symbol	Edge Condition	
F	Sharp	
E	Round	
T	Chamfer	
S	Chamfer and Round	

8-4 - Feed Direction

Symbol	Feed Direction	
R	Right-hand Insert	
N	Neutral Insert	
L	Left-hand Insert	

Milling Grades and Chipbreakers

Milling Grades

Milling Grades	P Steel				M Stainless steel				K Cast iron				N Non-ferrous				S Super alloys				H Hardened Steel				
	P05	P15	P25	P35	P45	M05	M15	M25	M35	K05	K15	K25	K35	N05	N15	N25	N35	S05	S15	S25	S35	H05	H15	H25	H35
PVD	YG012	012																						012	
	YG712	712																							
	YG713	713																							
	YG612		612				612													612					
	YG622		622								622														
	YG602		602				602				602								602						
	YG613		613				613																		
CVD	YG501									501															
	YG5020									5020															
Uncoated	YG50											50													

NEW YG012 H10 - H30 P10 - P30		Optimized Milling Grade for Pre-Hardened & Hardened steel • Applied Extreme Oxidation PVD layer and Crack-free Substrate • Excellent Cutting performance for Die & Mold application
YG712 P10 - P30		Milling Grade for Medium of Steel Application • Superior wear resistance and excellent toughness in high speed machining • Coating layer with high hardness and oxidation resistance
YG713 P15 - P25		Milling Grade for General Steel Application • Multi-layer TiAlN structure realizes stronger crater and flank wear resistance • Fine-grained carbide and balanced substrate
YG622 P20 - P35 K20 - K40		Optimized Grade for High Alloyed or Prehardened Steel Excellent for High Temperature Hardness and Oxidation Resistance at High Speed
NEW YG612 P20 - P40 M20 - M40 S20 - S40		Specialized Multi-Nano Coated Grade with high wear resistance and chipping resistance • Special Multi-Nano coating prevent crack and providing predictable tool life • Special universal Grade can achieve stable tool life in any workpiece

Milling Grades and Chipbreakers

Milling Grades













YG602 P20 - P35 M20 - M40 K20 - K40 S15 - S25		Universal grade for General Milling Application • Ultra Dense PVD Coating with optimal thermal resistance & strength • Sub-Micron substrate designed for demanding application
YG613 P30 - P50 M30 - M40		Milling Grade for Stainless Steel Application • New coating layer with lubrication preventing built-up edge on ultra fine grain substrate with high toughness. • The toughest substrate provides excellent cutting performance in stainless steel
YG501 K05 - K25		Hard Milling grade for Cast Iron • Substrate especially designed for high wear resistance • Excellent wear resistance in cast iron milling application
YG5020 K01 - K30		CVD Milling grade for Cast Iron • CVD coating for Excellent wear resistance • Improved Toughness for chipping resistance
YG50 N05 - N20		Uncoated Milling Grade for Aluminium • Submicron carbide substrate for high wear resistance • Preventing built up edge with shining surface

Milling Chipbreakers

-AL		• For Aluminum • Very Sharp Geometry
-ST		• For Stainless Steel, Super Alloy • Sharp Geometry
-GN (General Type)		• First Choice for General Application
-TR		• For Hardened Steels • Reinforced Geometry
...W / ...N		• For Hardened Material and Cast Irons

Milling Inserts Overview

Recommended Cutting Conditions : p.223

A 2 Corner	 Positive	ADKT	ADKT 1505	p. 149	
		AOMT	AOMT 1236	p. 149	
		APGT	APGT 1003, 1604	p. 150	
		APKT	APKT 1003, 1604	p. 151	
		APMT	APMT 1135, 1504, 1604	p. 152	
E 4 Corner	 Negative	ENMX	ENMX 0604 ENMX 0905	p. 153	
O Octagon	 Positive	ODMT / ODMW	ODMT / ODMW 0605	p. 155	
		OFER	OFER 0704	p. 156	
		OFMT	OFMT 05T3		
	 Negative	ONMU / ONHU	ONMU / ONHU 0806	p. 157	
P 10 Corner	 Negative	PNMU	PNMU1206	p. 158	
R Round	 Positive Round	RDKT / RDKW	RDKT 0802, 10T3, 1204, 1604 RDKW 0501, 0702, 0802, 10T3, 1204	p. 159	
		RDMT / RDMW	RDMT 0802, 0803, 10T3, 1204 RDMW 0802, 10T3, 1204	p. 160	
		RPMT / RPMW	RPMT 08T2, 10T3, 1204 RPMW 1003, 1204	p. 161	
S Square	 High Feed	SDMT / SDMW	SDMT 1204, SDMW 1204	p. 163	
		 Positive	SDCN (45°) / SDKN	SDKN, SDCN 1203, 1504	p. 162
			SEGT	SEGT12T3, 1204	p. 164
			SEKR (45°) / SEKN	SEKR, SEKN 1203	p. 167
			SEKT	SEKT 12T3, 1204	p. 165
			SEMT	SEMT1204, 13T3	p. 166
		 Negative	SPMT	SPMT 1204	p. 170
			SNMX	SNMX1206	p. 168
		 ISO	SPCN(75°) / SPKN / SPKR'	SPKN 1203, 1504 SPKR 1203 SPCN 1203, 1504	p. 169
			SPUN	SPUN 1203	p. 171
T Triangle	 Positive 3 Corner	TPKT	TPKT 1104, TPKT 1605	p. 172	
		 ISO	TPCN(90°) / TPKN / TPKR	TPKN 1603, 2204 TPKR 1603, 2204 TPCN 2204	p. 173
			TPUN	TPUN 1603	p. 174
W Trigon	 Negative 6 Corner	WNEX	WNEX0806	p. 175	

Milling - Shoulder Milling - Inserts

ADKT / AOMT - Shoulder Milling Positive (2 Corner)

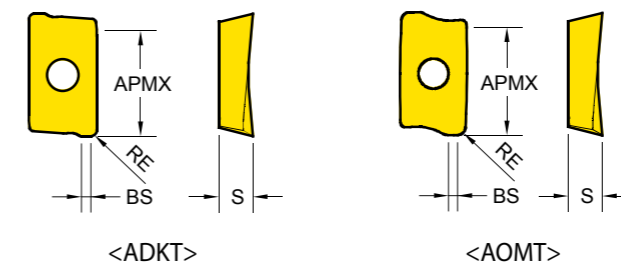

Series	APMX	IC	S
ADKT 1505	14	9.7	5.8
AOMT 1236	11	6.6	3.6

EDP 1200..

●: Stock item ○: Order made item

H20	P15	P25	P30	P30	P30	P40	K10	K15
P20			K30	M30	M30	M40		
			S30	S30	S40			
YG012	YG712	YG713	YG622	YG612	YG602	YG613	YG5020	YG501
				●	○			
				○	○			
				○	○			
				○	○			
				○	○			

ADKT	Designation	RE (mm)	Fz (mm/tooth)	BS (mm)	YG012	YG712	YG713	YG622	YG612	YG602	YG613	YG5020	YG501
ADKT General	ADKT 150508 PDTR	0.8	0.05~0.24	1.87						●			
	ADKT 150516 PDTR	1.6	0.05~0.24	1.73						○			
	ADKT 150524 PDTR	2.4	0.05~0.24	1.20						○			
	ADKT 150532 PDTR	3.2	0.05~0.24	0.30						○			
AOMT	Designation	RE (mm)	Fz (mm/tooth)	BS (mm)	YG012	YG712	YG713	YG622	YG612	YG602	YG613	YG5020	YG501
AOMT General	AOMT 123604 PDTR	0.4	0.03~0.06	1.07						●			
	AOMT 123608 PDTR	0.8	0.03~0.06	0.91						○	●		

Milling - Shoulder Milling - Inserts

APGT - Shoulder Milling Positive (2 Corner)

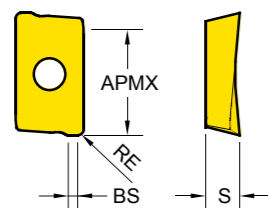

Series	APMX	IC	S
APGT 1035	9	6.7	3.6
APGT 1604	14	9.4	5.3

EDP 1200..

●: Stock item ○: Order made item

H20	P15	P25	P30	P30	P30	P40	K10	N15
P20			K30	M30	M30	M40		
			S30	S30	S40	S40		

APGT	Designation	RE (mm)	Fz (mm/tooth)	BS (mm)	YG012	YG712	YG713	YG622	YG612	YG602	YG613	YG5020	YG50
<p>NEW -AL Aluminium</p>	APGT 100305 - AL	0.5	0.05~0.25	1.4									● 0730
	APGT 160408 - AL	0.8	0.05~0.25	1.7									● 0428
	APGT 160430 - AL	3.0	0.05~0.25	0.2									● 0798

Milling - Shoulder Milling - Inserts

APKT - Shoulder Milling Positive (2 Corner)

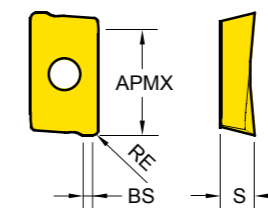

Series	APMX	IC	S
APKT 1003	9	6.7	3.6
APKT 1604	14	9.4	5.3

EDP 1200..

●: Stock item ○: Order made item

H20	P15	P25	P30	P30	P30	P40	K10	K15
P20			K30	M30	M30	M40		
			S30	S30	S40	S40		

APKT	Designation	RE (mm)	Fz (mm/tooth)	BS (mm)	YG012	YG712	YG713	YG622	YG612	YG602	YG613	YG5020	YG501
<p>APKT General</p>	APKT 100305 PDTR	0.5	0.05~0.24	0.86	● 0749	○ 0638	○ 0429		● 0005	● 0672			
	APKT 100308 PDTR	0.8	0.05~0.24	0.90	● 0750	○ 0632	○ 0430		● 0004	● 0610			
	APKT 100316 PDTR	1.6	0.05~0.24	1.03					● 0713	● 0714			
	APKT 160404 PDTR	0.4	0.05~0.25	1.11		○ 0656			● 0003				
	APKT 160408 PDTR	0.8	0.05~0.25	1.32	● 0797	○ 0633			● 0001	● 0607		● 0796	
	APKT 160412 PDTR	1.2	0.05~0.25	1.13		○ 0649			● 0002				
	APKT 160416 PDTR	1.6	0.05~0.25	1.13		○ 0661			● 0006				
	APKT 160424 PDTR	2.4	0.05~0.25	1.2		○ 0653			● 0255				
	APKT 160432 PDTR	3.2	0.05~0.25	0.4					● 0738				
	<p>-ST Stainless Steel Super Alloy</p>	APKT 100305 - ST	0.5	0.05~0.12	0.86					● 0278	● 0618		
APKT 100312 - ST		1.2	0.05~0.12	1.32						● 0776			
APKT 100316 - ST		1.6	0.05~0.12	1.03						● 0719			
APKT 160408 - ST		0.8	0.05~0.12	1.32					● 0270	● 0617			
<p>-TR Hardened Steel</p>	APKT 160404 - TR	0.4	0.05~0.40	2.12			○ 0505		● 0492				
	APKT 160408 - TR	0.8	0.05~0.40	1.32	● 0746	○ 0637	○ 0337		● 0256				
	APKT 160412 - TR	1.2	0.05~0.40	2.40			○ 0523		● 0493				
	APKT 160416 - TR	1.6	0.05~0.40	2.40	● 0747		○ 0524		● 0472				
	APKT 160424 - TR	2.4	0.05~0.40	1.50	● 0748		○ 0520		● 0494				

Milling - Shoulder Milling - Inserts
APMT - Shoulder Milling Positive (2 Corner)

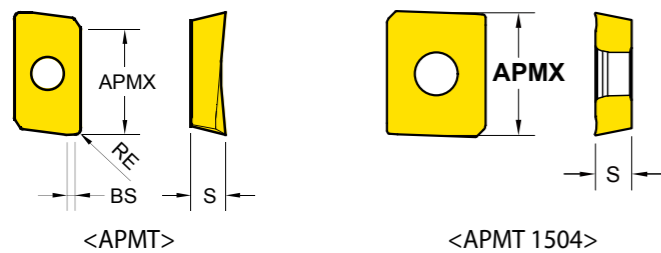

Series	APMX	IC	S
APMT 1135	9	6.2	3.50
APMT 1604	14	9.2	4.76
APMT 1504	14	12.7	4.76

EDP 1200..

●: Stock item ○: Order made item

H20	P15	P25	P30	P30	P30	P40	K10	K15
P20			K30	M30 S30	M30	M40 S40		

APMT	Designation	RE (mm)	Fz (mm/tooth)	BS (mm)	YG012	YG712	YG713	YG622	YG612	YG602	YG613	YG5020	YG501
APMT General	APMT 113504 PDTR	0.4	0.05~0.24	1.26	● 0752		○ 0655	○ 0400		● 0009			
	APMT 113508 PDTR	0.8	0.05~0.24	1.07			○ 0654			● 0010	● 0668		
	APMT 160408 PDTR	0.8	0.05~0.24	1.11	● 0751	● 0423	○ 0642	○ 0399		● 0008	● 0663		● 0464
APMT 1504 General	APMT 1504		0.05~0.24					○ 0445		● 0276			

Milling - High Feed Milling - Inserts
ENMX - High Feed Negative (4 Corners)

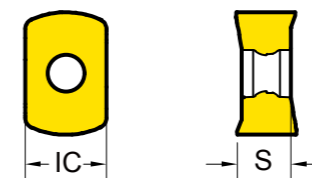

Series	IC	S
ENMX 0604	6.3	4.21
ENMX 0905	9.0	5.40

EDP 1200..

●: Stock item ○: Order made item

H20	P15	P25	P30	P30	P30	P40	K10	K15
P20			K30	M30 S30	M30	M40 S40		

ENMX	Designation	RE (mm)	Fz (mm/tooth)	BS (mm)	YG012	YG712	YG713	YG622	YG612	YG602	YG613	YG5020	YG501
ENMX General	ENMX 0604		0.3~2.0		● 0734					● 0474	● 0606		
	ENMX 0905		0.3~2.5		● 0736					● 0702	● 0703		
-ST Stainless Steel	ENMX 0604 - ST		0.1~0.8							● 0623	● 0625		
	ENMX 0905 - ST		0.2~1.2							● 0705	● 0706		
-TR Hardened Steel	ENMX 0604 - TR		0.3~2.5		● 0733	○ 0504	○ 0636			● 0459			
	ENMX 0905 - TR		0.3~3.0		● 0735					● 0600			

Milling - High Feed Milling - Inserts

ENMX - High Feed Negative (4 Corners) Technical Information

ENMX 0604

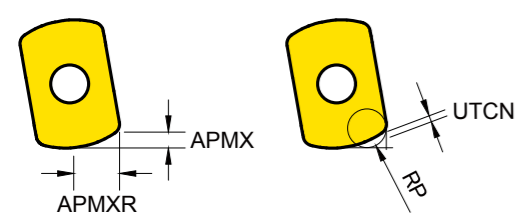

Unit:mm

DCX Cutting Diameter Maximum	APMXR Radial AP Max	RP Programmed Corner R	UTCN Uncut Thickness	Overcut
16	3.5	R2.0	0.31	0.00
16~	3.7	R2.5	0.18	0.18
		R3.0	0.07	0.36



DCX External Cutter Diameter	APMX Maximum Depth of Cut	APMXR Maximum Radial Depth of Cut	RMPX Maximum Ramping Angle(°)	RP Programmed Corner Radius	UTCN Uncut Thickness	Diameter Minimum Cutting Diameter	Diameter Maximum Cutting Diameter	Pitch Helical Interpolation Pitch	Ae Enlarge Width
16	0.9	3.5	2.4°	2.0	0.3	22	32	0.9	12.5
17	0.9	3.5	1.9°	2.0	0.3	24	34	0.9	13.5
20	1	3.7	1.8°	2.0	0.31	29	40	1	16.3
21	1	3.7	1.8°	2.0	0.31	31	42	1	17.3
25	1	3.7	1.2°	2.0	0.31	39	50	1	21.3
26	1	3.7	1.2°	2.0	0.31	41	52	1	22.3
32	1	3.7	0.8°	2.0	0.31	53	64	1	28.3
33	1	3.7	0.8°	2.0	0.31	55	66	1	29.3
40	1	3.7	0.6°	2.0	0.31	69	80	1	36.3
50	1	3.7	0.5°	2.0	0.31	89	98	1	46.3
63	1	3.7	0.4°	2.0	0.31	115	126	1	59.3

ENMX 0905

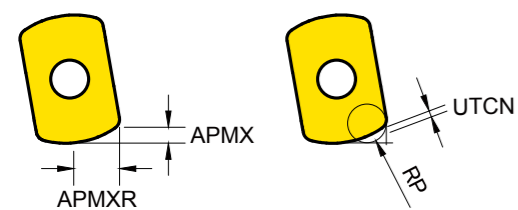

Unit:mm

APMXR Radial AP Max	RP Programmed Corner R	UTCN Uncut Thickness	Overcut
4.7	R2.5	0.56	0
	R3.0	0.40	0.10
	R3.5	0.24	0.25
	R4.0	0.10	0.41
	R4.5	0	0.49



DCX External Cutter Diameter	APMX Maximum Depth of Cut	APMXR Maximum Radial Depth of Cut	RMPX Maximum Ramping Angle(°)	RP Programmed Corner Radius	UTCN Uncut Thickness	Diameter Minimum Cutting Diameter	Diameter Maximum Cutting Diameter	Pitch Helical Interpolation Pitch	Ae Enlarge Width
25	1.5	5	3.8°	2.5	0.56	42	50	1.5	20
26	1.5	5	3.4°	2.5	0.56	44	52	1.5	21
32	1.5	5	2.3°	2.5	0.56	56	64	1.5	27
33	1.5	5	2.2°	2.5	0.56	58	66	1.5	28
40	1.5	5	1.6°	2.5	0.56	72	80	1.5	35
50	1.5	5	1.1°	2.5	0.56	92	100	1.5	45
63	1.5	5	0.8°	2.5	0.56	118	126	1.5	57
80	1.5	5	0.6°	2.5	0.56	152	160	1.5	74

Milling - Face Milling - Inserts

ODMT, ODMW - Face Milling Positive (8 Corners)

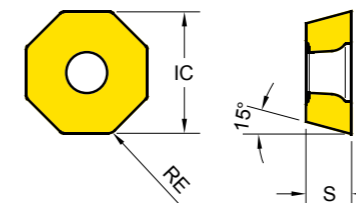

Series	IC	S
ODM*0605	15.9	5.6

EDP 1200..

●: Stock item ○: Order made item

H20	P15	P25	P30	P30	P30	P40	K10	K15
P20			K30	M30	M30	M40		
			S30	S40	S40			
YG012	YG712	YG713	YG622	YG612	YG602	YG613	YG5020	YG501
		○ 0659			● 0030	● 0675		
					● 0031			

**ODMT
ODMW**



Designation	RE (mm)	Fz (mm/tooth)	BS (mm)
ODMT 060508	0.8	0.05~0.30	
ODMW 060508	0.8	0.05~0.30	

Milling - Face Milling - Inserts

OFER, OFMT - Face Milling Positive (8 Corners)

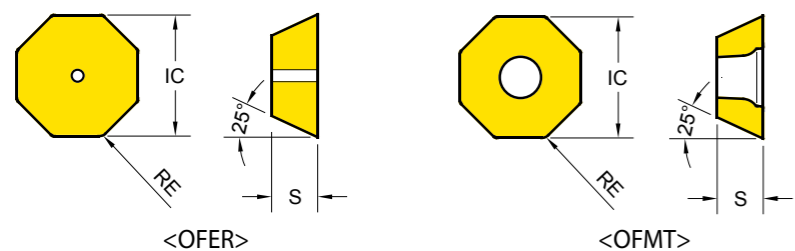

Series	IC	S
OFER 0704	18.05	4.78
OFMT 05T3	12.73	4.06

EDP 1200..

●: Stock item ○: Order made item

H20	P15	P25	P30	P30	P30	P40	K10	K15
P20			K30	M30	M30	M40		
			S30	S30	S40	S40		

OFER	Designation	RE (mm)	Fz (mm/tooth)	BS (mm)	YG012	YG712	YG713	YG622	YG612	YG602	YG613	YG5020	YG501
General	OFER 070405	0.5	0.05~0.30							● 0209			

OFMT	Designation	RE (mm)	Fz (mm/tooth)	BS (mm)	YG012	YG712	YG713	YG622	YG612	YG602	YG613	YG5020	YG501
General	OFMT 05T308	0.8	0.05~0.20							● 0032			

Milling - Face Milling - Inserts

ONHU / ONMU - Face Milling Negative (16 Corners)

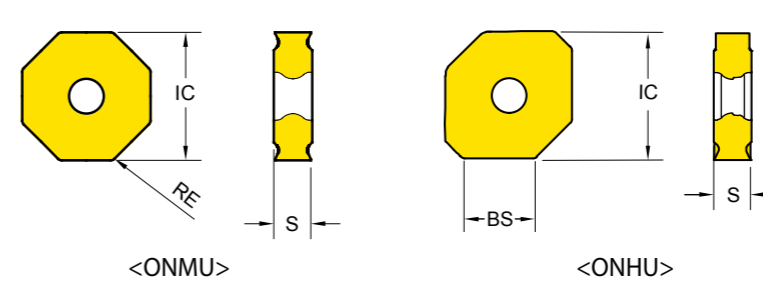

Series	IC	S
ON*U 0806	20.2	5.8

EDP 1200..

●: Stock item ○: Order made item

H20	P15	P25	P30	P30	P30	P40	K10	K15
P20			K30	M30	M30	M40		
			S30	S30	S40	S40		

ONMU / ONHU	Designation	RE (mm)	Fz (mm/tooth)	BS (mm)	YG012	YG712	YG713	YG622	YG612	YG602	YG613	YG5020	YG501
Wiper Insert	ONHU 080612	1.2	0.08~0.25	10.6								● 0482	● 0496
General	ONMU 080608	0.8	0.05~0.35		● 0609	○ 0657			● 0233	● 0670	● 0414		
	ONMU 080612	1.2	0.05~0.35							● 0615	● 0542		
	ONMU 080620	2.0	0.05~0.35									● 0707	

*Wiper Insert can use 4 corners for right handed cutter and 4 corners for left handed cutter

Milling - Face Milling - Inserts
PNMU - Face Milling Negative (10 Corners)

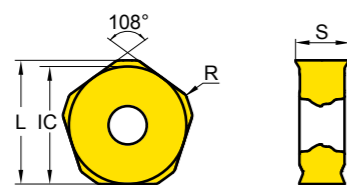

Series	KRINS	IC	S
PNMU 1206	36	14.0	5.84

EDP 1200..

●: Stock item ○: Order made item

H20	P15	P25	P30	P30	P30	P40	K10	K15
P20			K30	M30 S30	M30	M40 S40		

PNMU	Designation	RE (mm)	Fz (mm/tooth)	BS (mm)	EDP 1200..										
					YG012	YG712	YG713	YG622	YG612	YG602	YG613	YG5020	YG501G		
PNMU General	PNMU 1206ZNN	0.8	0.05 ~ 0.50	2.10	● 0753	● 0596	○ 0645				● 0826	● 0535	● 0671	● 0534	● 0538
	PNMU 1206-ST	0.8	0.05 ~ 0.30	2.10							● 0761	● 0760			

Milling - Profiling - Inserts
RDKT / W - Profiling Positive (Round)

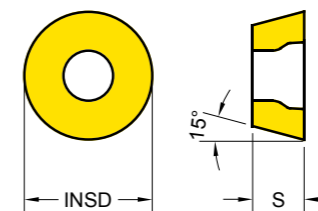

Series	INSD	S	Series	INSD	S
RDK* 0501	5	1.4	RDK* 10T3	10	4.0
RDK* 0702	7	2.4	RDK* 1204	12	4.8
RDK* 0802	8	2.4	RDK* 1604	16	4.8

EDP 1200..

●: Stock item ○: Order made item

H20	P15	P25	P30	P30	P30	P40	K10	K15
P20			K30	M30 S30	M30	M40 S40		

RDKT RDKW	Designation	Fz (mm/tooth)	EDP 1200..											
			YG012	YG712	YG713	YG622	YG612	YG602	YG613	YG5020	YG501			
RDKT General	RDKT 0802M0	0.05 ~ 0.25								● 0035				
	RDKT 10T3M0	0.05 ~ 0.30			○ 0651					● 0041				
	RDKT 1204M0	0.05 ~ 0.50			○ 0635					● 0034	● 0678			
	RDKT 1604M0	0.05 ~ 0.50								● 0539				
-ST Stainless Steel Super Alloy	RDKT 0802M0-ST	0.05 ~ 0.15								● 0292				
	RDKT 10T3M0-ST	0.05 ~ 0.20								● 0293	● 0620			
	RDKT 1204M0-ST	0.05 ~ 0.30								● 0294	● 0621			
-TR Hardened Steel	RDKT 0802M0-TR	0.05 ~ 0.35	● 0745			○ 0339				● 0284				
	RDKT 10T3M0-TR	0.05 ~ 0.40	● 0744			○ 0338				● 0285				
	RDKT 1204M0-TR	0.05 ~ 0.60	● 0743		○ 0650	○ 0340				● 0272				
RDKW Hard Materials	RDKW 0501M0	0.05 ~ 0.20				○ 0412				● 0207				
	RDKW 0702M0	0.05 ~ 0.25				○ 0439				● 0208				
	RDKW 0802M0	0.05 ~ 0.30				○ 0440				● 0043				
	RDKW 10T3M0	0.05 ~ 0.40				○ 0441				● 0040				
	RDKW 1204M0	0.05 ~ 0.60				○ 0647	○ 0442			● 0042				
	RDKW 1604M0	0.05 ~ 0.60	● 0817								● 0720			

Milling - Profiling - Inserts
RDMT / W - Profiling Positive (Round)

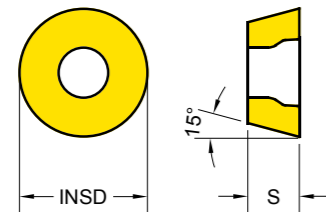

Series	INSD	S	Series	INSD	S
RDM* 0602	6	2.38	RDM* 10T3	10	3.97
RDM* 0802	8	2.38	RDM* 1204	12	4.76
RDM* 0803	8	3.18			

EDP 1200..
 ●: Stock item ○: Order made item

H20	P15	P25	P30	P30	P30	P40	K10	K15
P20			K30	M30	M30	M40		
			S30	S30	S40	S40		

	RDMT RDMW	Designation	Fz (mm/tooth)	EDP 1200..										
				YG012	YG712	YG713	YG622	YG612	YG602	YG613	YG5020	YG501		
RDMT General		RDMT 0602M0	0.05 ~ 0.20							●				
		RDMT 0802M0	0.05 ~ 0.25							●				
		RDMT 0803M0	0.05 ~ 0.25							●				
		RDMT 10T3M0	0.05 ~ 0.30							●				
RDMW Hard Materials		RDMT 1204M0	0.05 ~ 0.50							●				
		RDMW 0802M0	0.05 ~ 0.30							●				
		RDMW 10T3M0	0.05 ~ 0.40							●				
		RDMW 1204M0	0.05 ~ 0.60							●				

Milling - Profiling - Inserts
RPMT / W - Profiling Positive (Round)

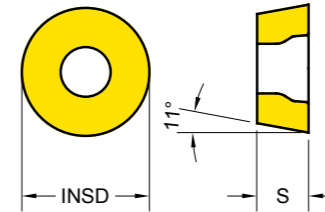

Series	INSD	S	Series	INSD	S
RPM* 08T2	8	2.78	RPM* 10T3	10	3.97
RPM* 1003	10	3.18	RPM* 1204	12	4.76

EDP 1200..
 ●: Stock item ○: Order made item

H20	P15	P25	P30	P30	P30	P40	K10	K15
P20			K30	M30	M30	M40		
			S30	S30	S40	S40		

	RPMT RPMW	Designation	Fz (mm/tooth)	EDP 1200..									
				YG012	YG712	YG713	YG622	YG612	YG602	YG613	YG5020	YG501	
RPMT General		RPMT 08T2M0	0.05 ~ 0.25			○				●	●		
		RPMT 10T3M0	0.05 ~ 0.30			○				●	●		
		RPMT 1204M0	0.05 ~ 0.50		●	○	○			●	●		●
-ST Stainless Steel Super Alloy		RPMT 1204M0 - ST	0.05 ~ 0.30							●	●		
										0230	0667		
RPMW Hard Materials		RPMW 1003M0	0.05 ~ 0.40			○	○			●			
		RPMW 1204M0	0.05 ~ 0.60			○				●			

Milling - Face Milling - Inserts

SDCN, SDKN - Face Milling Positive (4 Corners ISO)

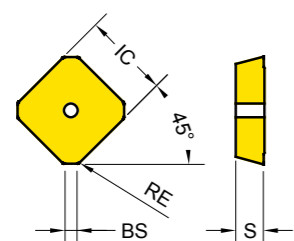

EDP 1200..

●: Stock item ○: Order made item

Series	IC	S
SD** 1203	12.70	3.18
SD** 1504	15.88	4.76

EDP 1200..

●: Stock item ○: Order made item

H20	P15	P25	P30	P30	P30	P40	K10	K15
P20			K30	M30	M30	M40		
			S30	S30	S40	S40		

SDCN SDKN	Designation	RE (mm)	Fz (mm/tooth)	BS (mm)	EDP 1200..													
					YG012	YG712	YG713	YG622	YG612	YG602	YG613	YG5020	YG501					
SDCN Ground insert	SDCN 1203 AESN - M	1.0	0.05 ~ 0.20	2.04		●												
	SDCN 1504 AESN - M	1.0	0.05 ~ 0.20	2.19		●												
	SDCN 1504 AESN - MR	1.0	0.05 ~ 0.20	2.19		●												
SDKN Hard Materials	SDKN 1203 AETN	0.5	0.05 ~ 0.30	1.85							●							
	SDKN 1203 AETN - PW	0.4	0.05 ~ 0.30	1.98							●							
	SDKN 1203 AETN - GW	1.3	0.05 ~ 0.30	1.85							●							
	SDKN 1203 AESN - GW	1.3	0.05 ~ 0.30	1.85	●													
	SDKN 1504 AETN	0.45	0.05 ~ 0.30	2.00							●							
	SDKN 1504 AETN - PW	0.4	0.05 ~ 0.30	1.95							●							
	SDKN 1504 AETN - GW	1.3	0.05 ~ 0.30	2.05							●							

- PW : for Improved Surface Roughness
- GW : Ground Wiper
- M : for Mold & Die
- MR : for Mold & Die Roughing

Milling - High Feed Milling - Inserts

SDMT / W - High Feed Positive (4 Corners)

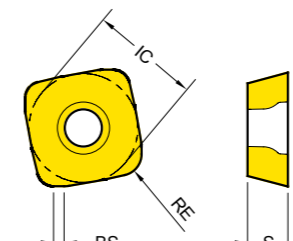

EDP 1200..

●: Stock item ○: Order made item

H20	P15	P25	P30	P30	P30	P40	K10	K15
P20			K30	M30	M30	M40		
			S30	S30	S40	S40		

SDMT SDMW	Designation	RE (mm)	Fz (mm/tooth)	BS (mm)	EDP 1200..													
					YG012	YG712	YG713	YG622	YG612	YG602	YG613	YG5020	YG501					
-ST Stainless Steel Super Alloy	SDMT 120420 - ST	1.9	0.60 ~ 1.20	1.45							●	●						
											0274	0666						
SDMW Hard Materials	SDMW 120420	1.9	0.60 ~ 1.40	1.4	●	○	○				●	●						
					0737	0634	0341				0273	0691						

Technical Information

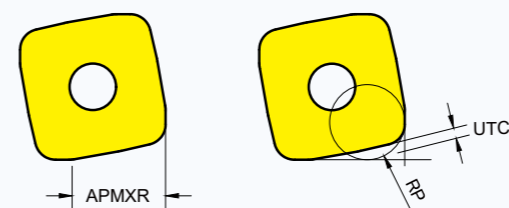

APMXR Radial AP Max	RP Programmed Corner R	UTCN Uncut Thickness
8.6	3.5	0.94

Milling - Face Milling - Inserts
SEGT - Face Milling Positive (4 Corners)

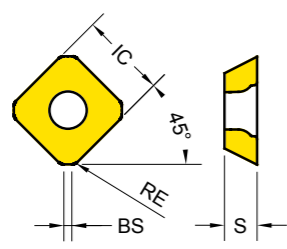

Series	IC	S
SEGT 1204	12.74	4.91
SEGT 12T3	13.40	4.03

EDP 1200..
 ●: Stock item ○: Order made item

H20	P15	P25	P30	P30	P30	P40	K10	N15
P20			K30	M30	M30	M40		
			S30	S30	S40	S40		

SEGT 1204	Designation	RE (mm)	Fz (mm/tooth)	BS (mm)	YG012	YG712	YG713	YG622	YG612	YG602	YG613	YG5020	YG50
-AL Aluminium	SEGT 1204-AL	1.2	0.05~0.30	2.01									● 0467

SEGT 12T3	Designation	RE (mm)	Fz (mm/tooth)	BS (mm)	YG012	YG712	YG713	YG622	YG612	YG602	YG613	YG5020	YG50
-AL Aluminium	SEGT 12T3-AL	1.2	0.05~0.30	1.94									● 0468

Milling - Face Milling - Inserts
SEKT - Face Milling Positive (4 Corners)

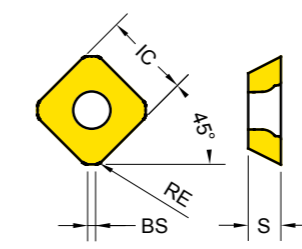

Series	IC	S
SEKT 1204	12.7	4.9
SEKT 12T3	13.4	4

EDP 1200..
 ●: Stock item ○: Order made item

H20	P15	P25	P30	P30	P30	P40	K10	K15
P20			K30	M30	M30	M40		
			S30	S30	S40	S40		

SEKT 1204	Designation	RE (mm)	Fz (mm/tooth)	BS (mm)	YG012	YG712	YG713	YG622	YG612	YG602	YG613	YG5020	YG501
SEKT 1204 General	SEKT 1204 AFTN	1.1	0.20~0.35	1.18				○ 0416		● 0055			
-ST Stainless Steel Super Alloy	SEKT 1204-ST	1.1	0.08~0.30	2.00						● 0257	● 0722		

SEKT 12T3	Designation	RE (mm)	Fz (mm/tooth)	BS (mm)	YG012	YG712	YG713	YG622	YG612	YG602	YG613	YG5020	YG501
SEKT 12T3 General	SEKT 12T3 AGTN	1.5	0.05~0.24	1.30						● 0056			
-ST Stainless Steel Super Alloy	SEKT 12T3-ST	1.5	0.05~0.12	2.00						● 0271	● 0689		

Milling - Face Milling - Inserts
SEMT - Face Milling Positive (4 Corners)

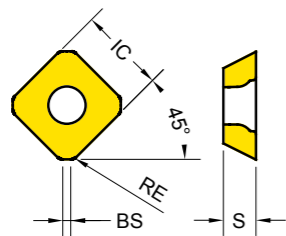

Series	IC	S
SEMT1204	12.92	5.1
SEMT13T3	13.40	4.0

EDP 1200..

●: Stock item ○: Order made item

H20	P15	P25	P30	P30	P30	P40	K10	K15
P20			K30	M30	M30	M40		
			S30	S30	S40	S40		

SEMT	Designation	RE (mm)	Fz (mm/tooth)	BS (mm)	YG012	YG712	YG713	YG622	YG612	YG602	YG613	YG5020	YG501
SEMT 1204 General	SEMT 1204 AFTN	1.2	0.05~0.24	1.24						● 0052			
	SEMT 13T3 AGSN	1.5	0.05~0.24	1.31						● 0203			

Milling - Face Milling - Inserts
SEKR / N - Face Milling Positive (4 Corners ISO)

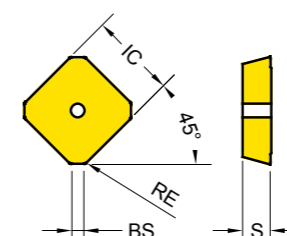

Series	IC	S
SEK* 1203	12.7	3.2

EDP 1200..

●: Stock item ○: Order made item

H20	P15	P25	P30	P30	P30	P40	K10	K15
P20			K30	M30	M30	M40		
			S30	S30	S40	S40		

SEKR SEKN	Designation	RE (mm)	Fz (mm/tooth)	BS (mm)	YG012	YG712	YG713	YG622	YG612	YG602	YG613	YG5020	YG501
SEKR General	SEKR 1203 AFTN	0.4	0.05~0.23	1.40						● 0051			
	SEKR 1203 AFTN - PW	0.4	0.05~0.24	2.00						● 0296			
SEKN Hard Materials	SEKN 1203 AFTN	0.4	0.05~0.30	1.40						● 0054			
	SEKN 1203 AFTN - GW	0.4	0.05~0.33	2.00	● 0774					● 0304			
	SEKN 1203 AFTN - PW	0.4	0.05~0.33	2.00						● 0297			

- PW : for Improved Surface Roughness
 - GW : Ground Wiper

Milling - Face Milling - Inserts
SNMX - Face Milling Negative (8 Corners)

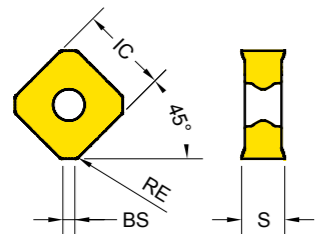

Series	IC	S
SNMX 1206	12.7	6.25

EDP 1200..

●: Stock item ○: Order made item

H20	P15	P25	P30	P30	P30	P40	K10	K15
P20			K30	M30	M30	M40		
			S30	S30	S40	S40		

SNMX	Designation	RE (mm)	Fz (mm/tooth)	BS (mm)	YG012	YG712	YG713	YG622	YG612	YG602	YG613	YG5020	YG501
General	SNMX 1206 ANN	0.8	0.05~0.24	1.70	● 0754		○ 0658			● 0231	● 0674	● 0460	
	SNMX 1206 QNN	0.8	0.05~0.24	1.99		● 0732						● 0731	● 0686

Milling - Face Milling - Inserts
SPCN, SPKN / R - Face Milling Positive (4 Corners ISO)

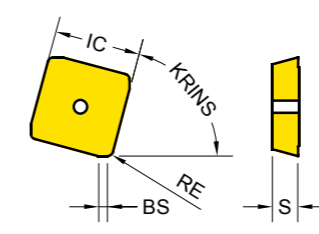

Series	KRINS	IC	S
SP** 1203	75°	12.70	3.18
SP** 1504	75°	15.88	4.76

EDP 1200..

●: Stock item ○: Order made item

H20	P15	P25	P30	P30	P30	P40	K10	K15
P20			K30	M30	M30	M40		
			S30	S30	S40	S40		

SPCN SPKN SPKR	Designation	RE (mm)	Fz (mm/tooth)	BS (mm)	YG012	YG712	YG713	YG622	YG612	YG602	YG613	YG5020	YG501
Ground insert	SPCN 1203 EDSR - M	0.8	0.10~0.20	1.82		● 0081							
	SPCN 1203 EDSR - MR	0.8	0.10~0.20	1.77		● 0198							
	SPCN 1504 EDSR - M	0.8	0.10~0.20	1.92		● 0098							
	SPCN 1504 EDSR - MR	0.8	0.10~0.20	1.86		● 0199							
Hard Materials	SPKN 1203 EDTR	0.8	0.05~0.30	1.40						● 0048			
	SPKN 1203 EDTR - GW	0.6	0.05~0.38	1.50						● 0280			
	SPKN 1203 EDTR - PW	0.8	0.05~0.38	1.50						● 0279			
	SPKN 1504 EDTR	0.8	0.05~0.24	1.30						● 0049			
	SPKN 1504 EDTR - GW	0.8	0.05~0.38	2.20						● 0305			
	SPKN 1504 EDTR - PW	0.8	0.05~0.38	2.13						● 0299			
General	SPKR 1203 EDTR	0.8	0.05~0.24	1.40						● 0050			
	SPKR 1203 EDTR - PW	0.8	0.05~0.11	1.54						● 0298			

- PW : for Improved Surface Roughness
- GW : Ground Wiper
- M : for Mold & Die
- MR : for Mold & Die Roughing

Milling - Face Milling - Inserts
SPMT - Universal Positive (4 Corners)

Series	AS	IC	S
SPMT 1204	11°	12.7	4.81

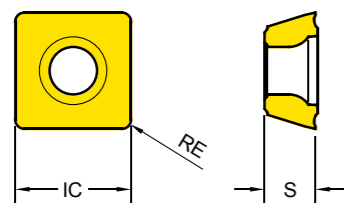

EDP 1200..
 ●: Stock item ○: Order made item

H20	P15	P25	P30	P30	P30	P40	K10	K15
P20			K30	M30 S30	M30	M40 S40		

SPMT	Designation	RE (mm)	Fz (mm/tooth)	BS (mm)	YG012	YG712	YG713	YG622	YG612	YG602	YG613	YG5020	YG501
SPMT	SPMT 120408	0.8	0.05~0.24							● 0223			

SPMT
General



Milling - Face Milling - Inserts
SPUN - Universal Positive (4 Corners ISO)

Series	AS	IC	S
SPUN 1203	11°	12.7	3.2

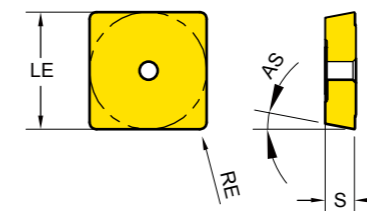

EDP 1200..
 ●: Stock item ○: Order made item

H20	P15	P25	P30	P30	P30	P40	K10	K15
P20			K30	M30 S30	M30	M40 S40		

SPUN	Designation	RE (mm)	Fz (mm/tooth)	BS (mm)	YG012	YG712	YG713	YG622	YG612	YG602	YG613	YG5020	YG501
SPUN	SPUN 120308	0.8	0.05~0.29							● 0224			

SPUN
General



Milling - Shoulder Milling - Inserts

TPKT - Shoulder Milling Positive (3 Corner ISO)

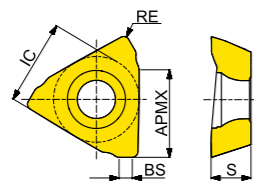

Series	KRINS	IC	S
TP** 1104	90	7.54	4.28
TP** 1605	90	11.66	5.38

EDP 1200..

●: Stock item ○: Order made item

H20	P15	P25	P30	P30	P30	P40	K10	K15
P20			K30	M30 S30	M30	M40 S40		

TPKT	Designation	RE (mm)	Fz (mm/tooth)	BS (mm)	EDP 1200..									
					YG012	YG712	YG713	YG622	YG612	YG602	YG613	YG5020	YG501	
NEW TPKT General	TPKT 110404R - GN	0.4	0.05 ~ 0.24	1.60	●	●				●		●		
	TPKT 110408R - GN	0.8	0.05 ~ 0.24	1.15	●	●				●		●		
	TPKT 110416R - GN	1.6	0.05 ~ 0.24	0.60	●	●				●		●		
	TPKT 160508R - GN	0.8	0.05 ~ 0.27	1.79	●	●				●		●		
	TPKT 160516R - GN	1.6	0.05 ~ 0.27	1.20	●	●				●		●		
	TPKT 160524R - GN	2.4	0.05 ~ 0.27	0.70	●	●				●		●		
NEW -ST Stainless Steel Super Alloy	TPKT 110404R - ST	0.4	0.05 ~ 0.15	1.60						●	●			
	TPKT 110408R - ST	0.8	0.05 ~ 0.15	1.15						●	●			
	TPKT 160508R - ST	0.8	0.05 ~ 0.15	0.60						●	●			

Milling - Shoulder Milling - Inserts

TPCN / TPKN / TPKR - Shoulder Milling Positive (3 Corner ISO)

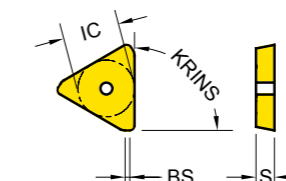

Series	KRINS	IC	S
TP** 1603	90	9.53	3.18
TP** 2204	90	12.7	4.85

EDP 1200..

●: Stock item ○: Order made item

H20	P15	P25	P30	P30	P30	P40	K10	K15
P20			K30	M30 S30	M30	M40 S40		

TPCN TPKN TPKR	Designation	RE (mm)	Fz (mm/tooth)	BS (mm)	EDP 1200..									
					YG012	YG712	YG713	YG622	YG612	YG602	YG613	YG5020	YG501	
TPCN Ground insert	TPCN 2204 PDSR - M		0.05 ~ 0.20	1.76		●								
	TPCN 2204 PDSR - MR		0.05 ~ 0.20	1.76		●								
TPKN Hard Materials	TPKN 1603 PDTR		0.05 ~ 0.21	1.2							●			
	TPKN 1603 PDTR - GW		0.05 ~ 0.15	1.6							●			
	TPKN 1603 PDTR - PW		0.05 ~ 0.30	1.2							●			
	TPKN 2204 PDTR		0.05 ~ 0.24	1.7							●			
	TPKN 2204 PDTR - GW		0.05 ~ 0.45	2.5							●			
	TPKN 2204 PDTR - PW		0.05 ~ 0.29	1.7							●			
TPKR General	TPKR 1603 PDTR		0.15 ~ 0.28	1.2							●	●		
	TPKR 1603 PDTR - PW		0.11 ~ 0.20	1.2							●			
	TPKR 2204 PDTR		0.18 ~ 0.35	1.7							●	●		
	TPKR 2204 PDTR - PW		0.18 ~ 0.35	1.7							●			

- PW : for Improved Surface Roughness
- GW : Ground Wiper
- M : for Mold & Die
- MR : for Mold & Die Roughing

Milling - Shoulder Milling - Inserts
TPUN - Universal Positive (3 Corners ISO)

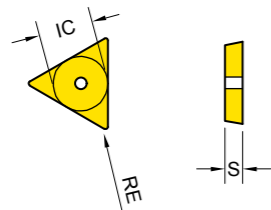

Series	IC	S
TPUN 1603	9.53	3.18

EDP 1200..

●: Stock item ○: Order made item

H20	P15	P25	P30	P30	P30	P40	K10	K15
P20			K30	M30 S30	M30	M40 S40		

TPUN	Designation	RE (mm)	Fz (mm/tooth)	BS (mm)	YG012	YG712	YG713	YG622	YG612	YG602	YG613	YG5020	YG501
	TPUN 160308	0.8	0.08~0.15							● 0064			

TPUN



Milling - Shoulder Milling - Inserts
WNEX - Shoulder Milling Negative (6 Corners)

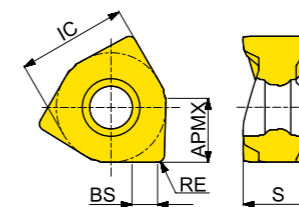

Series	IC	S
WNE* 0806	12.9	6.25

EDP 1200..

●: Stock item ○: Order made item

H20	P15	P25	P30	P30	P30	P40	K10	K15
P20			K30	M30 S30	M30	M40 S40		

WNEX	Designation	RE (mm)	Fz (mm/tooth)	BS (mm)	YG012	YG712	YG713	YG622	YG612	YG602	YG613	YG5020	YG501
	WNEX 080604R - GN	0.4	0.05~0.26	3.2	● 0856	● 0857			● 0855			● 0858	
	WNEX 080608R - GN	0.8	0.05~0.26	2.8	● 0859	● 0792			● 0854		● 0793	● 0794	● 0795
	WNEX 080612R - GN	1.2	0.05~0.26	2.4	● 0877	● 0878			● 0885			● 0879	
	WNEX 080616R - GN	1.6	0.05~0.26	2.0	● 0861	● 0862			● 0860			● 0863	
	WNEX 080620R - GN	2.0	0.05~0.26	1.6	● 0882	● 0883			● 0886			● 0884	
	WNEX 080604R - ST	0.4	0.05~0.19	3.6					● 0864			● 0865	
	WNEX 080608R - ST	0.8	0.05~0.19	3.3					● 0866			● 0867	
	WNEX 080612R - ST	1.2	0.05~0.19	2.8					● 0875			● 0876	
	WNEX 080616R - ST	1.6	0.05~0.19	2.4					● 0868			● 0869	
	WNEX 080620R - ST	2.0	0.05~0.19	2.0					● 0880			● 0881	

NEW

WNEX
General



NEW



-ST
Stainless Steel
Super Alloy





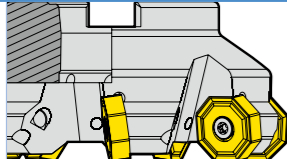
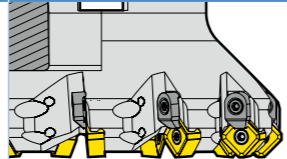
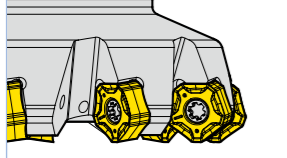
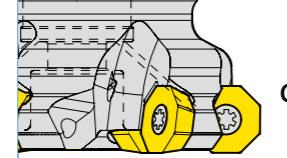
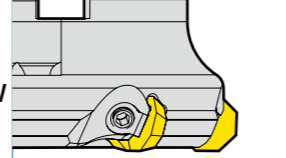
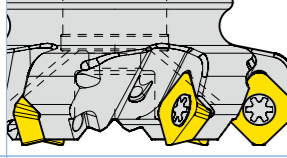

Milling Cutters Overview

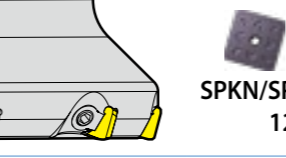
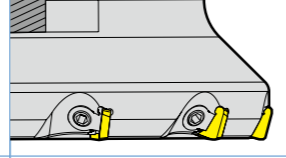
Mounting Bolt : p. 197

Face Milling

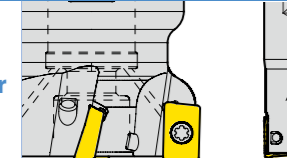
Negative Octagonal		Negative Square	
Cutter	 ONMU 0806	 SNMX 1206	
APMX	5.5	6	
DC	Ø63~315	Ø50~200	
page	185	192	
Negative 10 Corner		Positive Octagonal	
Cutter	 PNMU 1206	 ODMT/ODMW 0605	 OFER 0704
APMX	4	3.5	5
DC	Ø50~125	Ø63~125	Ø63~160
page	186	184	184
Positive Square			ISO
Cutter	 SEKT 1204	 SEKT 12T3	 SEGT 1204
APMX	6	6	6
DC	Ø40~160	Ø50~160	Ø50~160
page	190	190	190
Cutter	 SPKN/SPKR/SPCN 1203		
APMX	8		
DC	Ø50~200		
page	191		

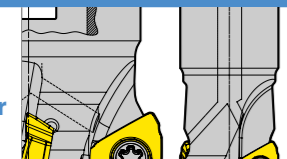
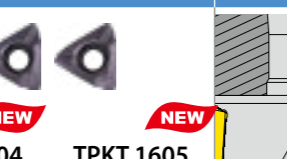
Shoulder Milling

2 Corner Positive		ISO	
Cutter	 APKT 1003	 APKT 1604	
APMX	9	14	
DC	Ø16~100	Ø25~200	
page	178-179	180-181	
3 Corner Positive		ISO	
Cutter	 TPKT 1104	 TPKT 1605	 TPKN/TPKR/TPCN 1603
APMX	7.0	11.0	12
DC	20~63	32~200	Ø50~125
page	194	195	193
Cutter	 TPKN/TPKR/TPCN 2204		
APMX	18		
DC	Ø63~315		
page	193		



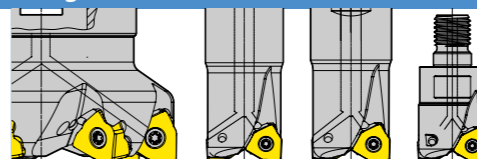

Milling Cutters Overview

Mounting Bolt : p. 197

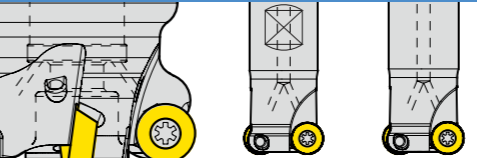

Shoulder Milling

6 Corner Negative	
Cutter	 WNEX0806
APMX	7
DC	Ø32~125
page	196

Profiling

Round Positive		RDKT / RDKW		
Cutter				
APMX	4	5	6	
DCX	Ø16~25	Ø20~63	Ø25~100	
page	187	187	188	

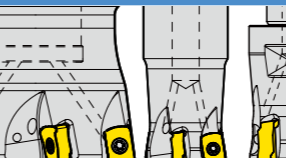
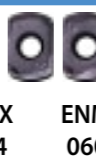
High Feed Milling

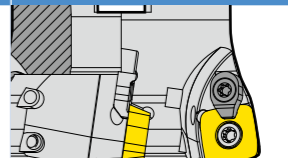
Negative 4 Corner			Positive 4 Corner	
Cutter	 ENMX 0604	 ENMX 0604	 ENMX 0905	 SDMT/SDMW 1204
APMX	0.9	1	1.5	1.8
DCX	Ø16~18	Ø20~50	Ø25~125	Ø32~100
page	182	182	183	189

Modular Shank

Modular Shank for Modular Head	
Cutter	 M08 ~ M16
page	197

Milling - Shoulder Milling - Cutter Cutters for APKT

Entering Angle : 90°
2 Corner Positive

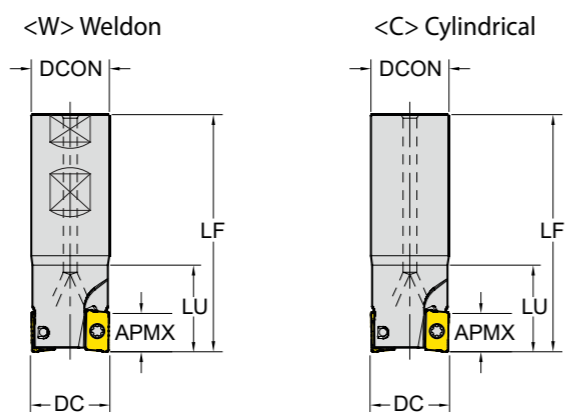

CICT : Number of Inserts
CBDP : Connection Bore Depth

□: p. 151 Unit:mm

Series	APMX	Designation	EDP 1700..	DC	CICT	LU	LF	TYPE	DCON	CBDP	DCSFMS	PCD1	PCD2	☉
APKT 1003	9.0	E90 - APKT10 - D16Z2C16 - L100	0083	16	2	40	100	Cylindrical	16	-	-	-	-	●
		E90 - APKT10 - D16Z2C16 - L120	0532	16	2	30	120		16	-	-	-	-	●
		E90 - APKT10 - D16Z2C16 - L150	0154	16	2	40	150		16	-	-	-	-	●
		E90 - APKT10 - D16Z2C16 - L200	0533	16	2	100	200		16	-	-	-	-	●
		E90 - APKT10 - D20Z2C20 - L250	0534	20	2	150	250		20	-	-	-	-	●
		E90 - APKT10 - D20Z3C20 - L100	0535	20	3	30	100		20	-	-	-	-	●
		E90 - APKT10 - D20Z3C20 - L120	0085	20	3	40	120		20	-	-	-	-	●
		E90 - APKT10 - D20Z3C20 - L150	0536	20	3	50	150		20	-	-	-	-	●
		E90 - APKT10 - D20Z3C20 - L200	0270	20	3	100	200		20	-	-	-	-	●
		E90 - APKT10 - D25Z3C25 - L100	0537	25	3	30	100		25	-	-	-	-	●
		E90 - APKT10 - D25Z3C25 - L120	0186	25	3	40	120	25	-	-	-	-	●	
		E90 - APKT10 - D30Z4C25 - L100	0122	30	4	30	100	25	-	-	-	-	●	
		E90 - APKT10 - D30Z4C25 - L120	0086	30	4	30	120	25	-	-	-	-	●	
		E90 - APKT10 - D32Z4C25 - L100	0538	32	4	35	100	25	-	-	-	-	●	
		E90 - APKT10 - D32Z4C25 - L150 - WOC	0539	32	4	35	150	25	-	-	-	-	X	
		E90 - APKT10 - D12Z1W16 - L100	0540	12	1	30	100	16	-	-	-	-	●	
		E90 - APKT10 - D14Z1W16 - L100	0541	14	1	30	100	16	-	-	-	-	●	
		E90 - APKT10 - D16Z2W16 - L100	0542	16	2	30	100	16	-	-	-	-	●	
		E90 - APKT10 - D16Z2W16 - L85	0082	16	2	-	85	16	-	-	-	-	●	
		E90 - APKT10 - D18Z2W16 - L100	0543	18	2	30	100	16	-	-	-	-	●	

▶ NEXT PAGE

* Clamping Torque (Nm) 1.2Nm

APKT10	Screw (Cutter D16~D20)	Screw (Cutter D20~)	Wrench
Description	TP072505	TP072506	TPWFTP07
EDP	18000016	18000013	18000001

Milling - Shoulder Milling - Cutter Cutters for APKT

Entering Angle : 90°
2 Corner Positive

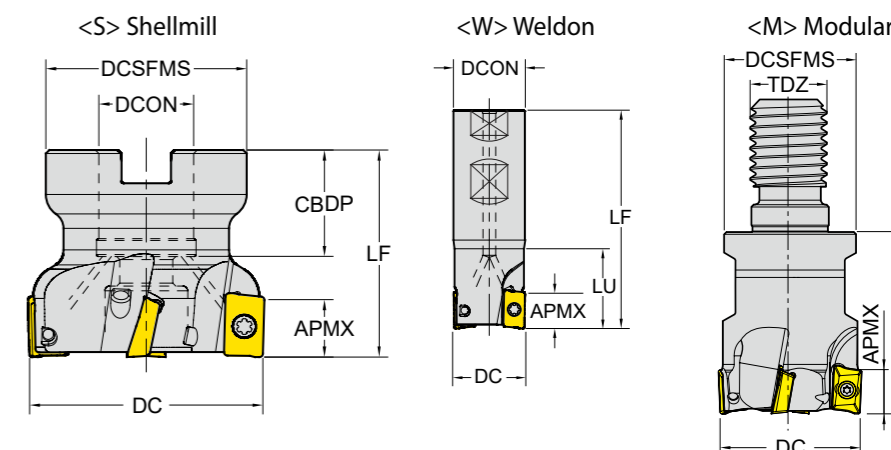

CICT : Number of Inserts
CBDP : Connection Bore Depth

□: p. 151 Unit:mm

Series	APMX	Designation	EDP 1700..	DC	CICT	LU	LF	TYPE	DCON / TDZ	CBDP	DCSFMS	PCD1	PCD2	☉	
APKT 1003	9.0	E90 - APKT10 - D20Z3W20 - L100	0461	20	3	30	100	Weldon	20	-	-	-	-	●	
		E90 - APKT10 - D20Z3W20 - L90	0084	20	3	40	90		20	-	-	-	-	●	
		E90 - APKT10 - D22Z3W20 - L100	0544	22	3	30	100		20	-	-	-	-	●	
		E90 - APKT10 - D25Z3W25 - L100	0545	25	3	30	100		25	-	-	-	-	●	
		E90 - APKT10 - D25Z4W25 - L100	0546	25	4	30	100		25	-	-	-	-	●	
		E90 - APKT10 - D32Z4W32 - L150 - WOC	0547	32	4	50	150		32	-	-	-	-	X	
		F90 - APKT10 - D40Z4S16	0087	40	4	-	40		16	18	34	-	-	-	●
		F90 - APKT10 - D40Z5S16	0472	40	5	-	40		16	20	36	-	-	-	●
		F90 - APKT10 - D50Z6S22	0215	50	6	-	40	22	22	42	-	-	-	●	
		F90 - APKT10 - D50Z7S22	0088	50	7	-	40	22	20	42	-	-	-	●	
		F90 - APKT10 - D63Z7S22	0548	63	7	-	40	22	22	48	-	-	-	●	
		F90 - APKT10 - D80Z8S27	0549	80	8	-	50	27	25	58	-	-	-	●	
		F90 - APKT10 - D100Z9S32	0550	100	9	-	50	32	26	65	-	-	-	●	
		M90 - APKT10 - D16Z2M08	0551	16	2	-	30	M08	-	14.75	-	-	-	●	
		M90 - APKT10 - D20Z3M10	0552	20	3	-	30	M10	-	18	-	-	-	●	
		M90 - APKT10 - D25Z3M12	0553	25	3	-	35	M12	-	21	-	-	-	●	
		M90 - APKT10 - D32Z4M16	0554	32	4	-	35	M16	-	29	-	-	-	●	
		M90 - APKT10 - D40Z5M16	0555	40	5	-	43	M16	-	29	-	-	-	●	
		M90 - APKT10 - D42Z5M16	0556	42	5	-	43	M16	-	29	-	-	-	●	

* Clamping Torque (Nm) 1.2Nm

APKT10	Screw (Cutter D16~D20)	Screw (Cutter D20~)	Wrench
Description	TP072505	TP072506	TPWFTP07
EDP	18000016	18000013	18000001

Milling - Shoulder Milling - Cutter Cutters for APKT

Entering Angle : 90°
2 Corner Positive

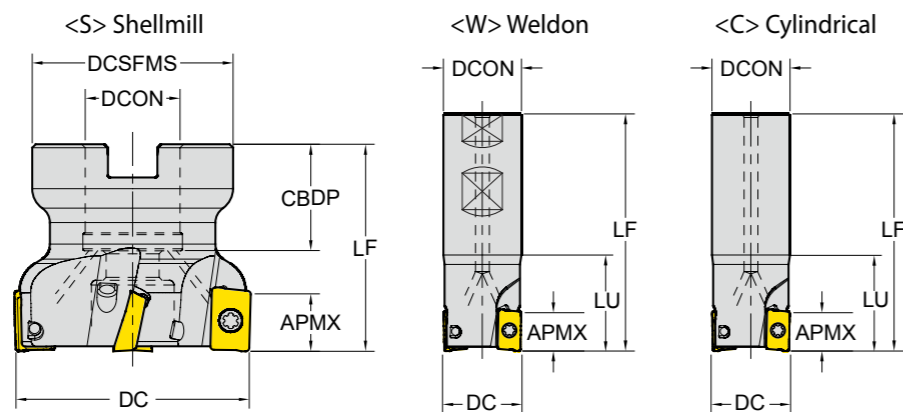

CICT : Number of Inserts
CBDP : Connection Bore Depth

Unit:mm

Series	APMX	Designation	EDP 1700..	DC	CICT	LU	LF	TYPE	DCON	CBDP	DCSFMS	PCD1	PCD2	Drop	
APKT 1604	14.0	E90 - APKT16 - D25Z2C20 - L100	0091	25	2	-	100	Shellmill	20	-	-	-	-	●	
		E90 - APKT16 - D25Z2C20 - L100 - WOC	0243	25	2	35	100		20	-	-	-	-	-	X
		E90 - APKT16 - D25Z2C25 - L250 - WOC	0557	25	2	100	250		25	-	-	-	-	-	X
		E90 - APKT16 - D32Z2C32 - L250 - WOC	0558	32	2	100	250		32	-	-	-	-	-	X
		E90 - APKT16 - D32Z3C25 - L110	0094	32	3	-	110	Cylindrical	25	-	-	-	-	-	●
		E90 - APKT16 - D32Z3C25 - L200	0559	32	3	40	200		25	-	-	-	-	-	●
		E90 - APKT16 - D32Z3C32 - L150 - WOC	0250	32	3	50	150		32	-	-	-	-	-	X
		E90 - APKT16 - D32Z3C32 - L250 - WOC	0560	32	3	100	250		32	-	-	-	-	-	X
		E90 - APKT16 - D40Z4C32 - L150 - WOC	0561	40	4	40	150	32	-	-	-	-	-	-	X
		E90 - APKT16 - D25Z2W25 - L100	0562	25	2	35	100	Weldon	25	-	-	-	-	-	●
		E90 - APKT16 - D25Z2W25 - L110	0092	25	2	-	110		25	-	-	-	-	-	●
		E90 - APKT16 - D28Z3W25 - L100	0563	28	3	40	100		25	-	-	-	-	-	●
		E90 - APKT16 - D30Z3W25 - L110	0564	30	3	40	110		25	-	-	-	-	-	●
		E90 - APKT16 - D32Z3W25 - L110	0093	32	3	-	110		25	-	-	-	-	-	●
		E90 - APKT16 - D32Z3W32 - L110	0565	32	3	40	110		32	-	-	-	-	-	●
		E90 - APKT16 - D36Z3W32 - L110	0566	36	3	40	110		32	-	-	-	-	-	●
		F90 - APKT16 - D40Z4S16	0275	40	4	-	40		Shellmill	16	20	36	-	-	-
		F90 - APKT16 - D50Z5S22	0095	50	5	-	40	22		20	45	-	-	-	●

▶ NEXT PAGE

* Clamping Torque (Nm) 3.0Nm

APKT16	Screw	Wrench
Description	TP154008	TPWFTP15
EDP	18000006	18000003

Milling - Shoulder Milling - Cutter Cutters for APKT

Entering Angle : 90°
2 Corner Positive

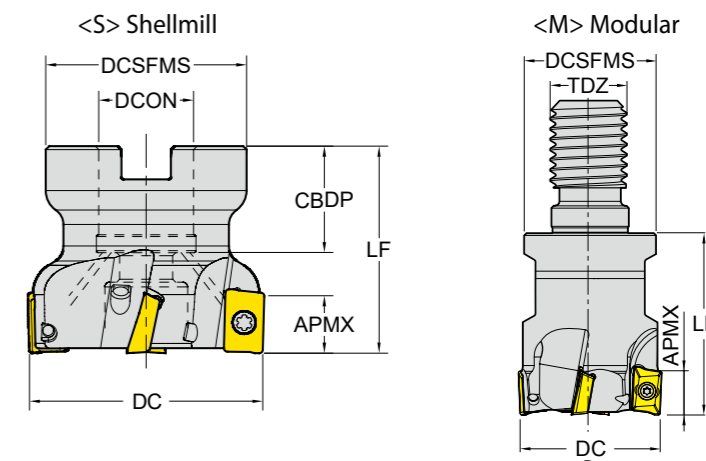

CICT : Number of Inserts
CBDP : Connection Bore Depth

Unit:mm

Series	APMX	Designation	EDP 1700..	DC	CICT	LU	LF	TYPE	DCON /TDZ	CBDP	DCSFMS	PCD1	PCD2	Drop	
APKT 1604	14.0	F90 - APKT16 - D52Z5S22	0567	52	5	-	40	Shellmill	22	22	42	-	-	●	
		F90 - APKT16 - D63Z6S22	0096	63	6	-	40		22	20	50	-	-	●	
		F90 - APKT16 - D80Z7S27	0097	80	7	-	50		27	23	56	-	-	●	
		F90 - APKT16 - D100Z8S32	0181	100	8	-	50		32	26	65	-	-	●	
		F90 - APKT16 - D125Z9S40 - WOC	0238	125	9	-	63		40	32	80	-	-	-	X
		F90 - APKT16 - D160Z10S40 - WOC	0568	160	10	-	63		40	32	110	66.7	-	-	X
		F90 - APKT16 - D200Z12S60 - WOC	0569	200	12	-	63		60	40	130	101.6	-	-	X
		M90 - APKT16 - D25Z2M12	0570	25	2	-	43		Modular	M12	-	21	-	-	●
		M90 - APKT16 - D32Z3M16	0571	32	3	-	43	M16		-	29	-	-	●	
		M90 - APKT16 - D42Z4M16	0572	42	4	-	43	M16		-	29	-	-	●	

* Clamping Torque (Nm) 3.0Nm

APKT16	Screw	Wrench
Description	TP154008	TPWFTP15
EDP	18000006	18000003

Milling - High Feed Milling - Cutter Cutters for ENMX

Entering Angle : 10°
4 Corner Negative

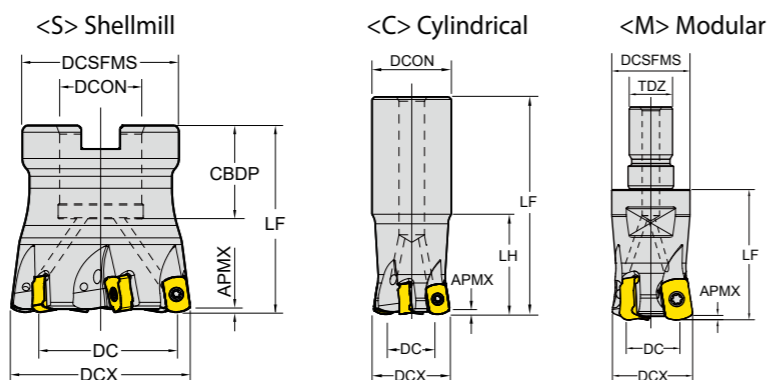

CICT : Number of Inserts
CBDP : Connection Bore Depth

Unit : mm

Series	APMX	Designation	EDP 1700..	DC	DCX	CICT	LF	Type	DCON /TDZ	LH	CBDP	DCSFMS	⚙️
0.9		EHF - ENMX06 - D16Z2C16 - L100	0644	9.0	16	2	100	Cylindrical	16	30	-	-	●
		EHF - ENMX06 - D16Z2C16 - L150	0645	9.0	16	2	150		16	50	-	-	●
		EHF - ENMX06 - D17Z2C16 - L100	0674	10.0	17	2	100		16	20	-	-	●
		EHF - ENMX06 - D17Z2C16 - L150	0473	10.0	17	2	150		16	20	-	-	●
1		EHF - ENMX06 - D20Z3C20 - L130	0463	12.6	20	3	130	Cylindrical	20	50	-	-	●
		EHF - ENMX06 - D20Z3C20 - L160	0646	12.6	20	3	160		20	80	-	-	●
		EHF - ENMX06 - D21Z3C20 - L150	0475	13.6	21	3	150		20	20	-	-	●
		EHF - ENMX06 - D21Z3C20 - L200	0476	13.6	21	3	200		20	20	-	-	●
		EHF - ENMX06 - D25Z4C25 - L140	0647	17.6	25	4	140		25	60	-	-	●
		EHF - ENMX06 - D25Z4C25 - L180	0464	17.6	25	4	180		25	80	-	-	●
		EHF - ENMX06 - D25Z4C25 - L250	0648	17.6	25	4	250		25	120	-	-	●
		EHF - ENMX06 - D26Z4C25 - L150	0479	18.6	26	4	150		25	30	-	-	●
0.9		EHF - ENMX06 - D26Z4C25 - L200	0480	18.6	26	4	200	Cylindrical	25	30	-	-	●
		EHF - ENMX06 - D32Z5C32 - L150	0649	24.6	32	5	150		32	70	-	-	●
		EHF - ENMX06 - D32Z5C32 - L200	0465	24.6	32	5	200		32	100	-	-	●
		MHF - ENMX06 - D16Z2M08	0691	9.0	16	2	23		Modular	M08	-	-	13
MHF - ENMX06 - D18Z2M08	0730	11.0	18	2	23	M08	-	-		13	●		
MHF - ENMX06 - D20Z3M10	0692	12.6	20	3	30	M10	-	-		18	●		
MHF - ENMX06 - D25Z4M12	0693	17.6	25	4	35	M12	-	-		21	●		
1		MHF - ENMX06 - D32Z5M16	0694	24.6	32	5	42	Modular	M16	-	-	29	●
		MHF - ENMX06 - D35Z5M16	0695	27.6	35	5	42		M16	-	-	29	●
		MHF - ENMX06 - D40Z6M16	0732	32.6	40	6	42		M16	-	-	29	●
1		MHF - ENMX06 - D42Z6M16	0696	34.6	42	6	42	Modular	M16	-	-	29	●
		FHF - ENMX06 - D40Z6S16	0482	32.6	40	6	40		Shellmill	16	-	18	37
		FHF - ENMX06 - D50Z6S22	0471	42.6	50	6	50	22		-	25	42	●

* Clamping Torque (Nm) 1.2Nm

ENMX06	Screw	Wrench	Handle	BIT
Description	TP082507-GS	TPWBTP08	DH-H4	DB-TP08
EDP	18000206	18000218	18000189	18000190

Milling - High Feed Milling - Cutter Cutters for ENMX

Entering Angle : 10°
4 Corner Negative

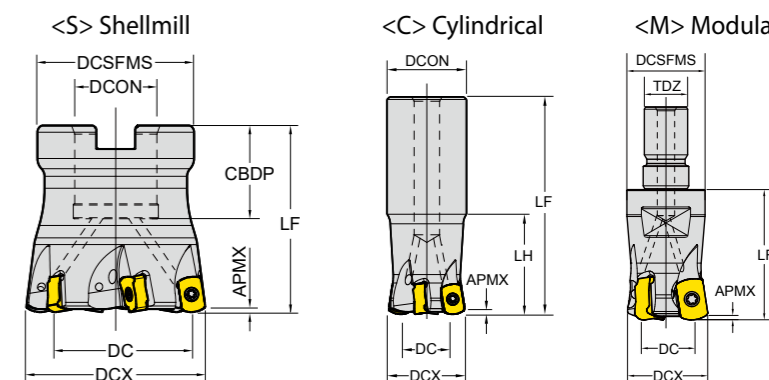

CICT : Number of Inserts
CBDP : Connection Bore Depth

Unit : mm

Series	APMX	Designation	EDP 1700..	DC	DCX	CICT	LF	Type	DCON /TDZ	LH	CBDP	DCSFMS	⚙️
ENMX 0905	1.5	EHF - ENMX09 - D25Z2C25 - L150	0745	15	25	2	150	Cylindrical	25	70	-	-	●
		EHF - ENMX09 - D26Z2C25 - L200	0746	16	26	2	200		25	30	-	-	●
		EHF - ENMX09 - D26Z3C25 - L200	0747	16	26	3	200		25	30	-	-	●
		EHF - ENMX09 - D32Z3C32 - L160	0748	22	32	3	160		32	70	-	-	●
		EHF - ENMX09 - D33Z3C32 - L200	0749	23	33	3	200		32	30	-	-	●
		EHF - ENMX09 - D33Z4C32 - L200	0750	23	33	4	200		32	40	-	-	●
		EHF - ENMX09 - D40Z5C32 - L180	0751	30	40	5	180		32	40	-	-	●
		FHF - ENMX09 - D50Z3S22	0820	40	50	3	50		Shellmill	22	-	20	42
		FHF - ENMX09 - D50Z4S22	0821	40	50	4	50	22		-	20	42	●
		FHF - ENMX09 - D50Z5S22	0752	40	50	5	50	22		-	20	42	●
		FHF - ENMX09 - D63Z4S22	0822	53	63	4	50	22		-	20	48	●
		FHF - ENMX09 - D63Z5S22	0823	53	63	5	50	22		-	20	48	●
		FHF - ENMX09 - D63Z6S22	0753	53	63	6	50	22		-	20	48	●
		FHF - ENMX09 - D63Z7S22	0754	53	63	7	50	22		-	20	48	●
		FHF - ENMX09 - D80Z8S27	0755	70	80	8	50	27		-	23	56	●
				FHF - ENMX09 - D100Z10S32	0824	90	100	10	63	32	-	26	78
		FHF - ENMX09 - D125Z12S40	0825	115	125	12	63	40	-	28	89	●	

* Clamping Torque (Nm) 2.0Nm

ENMX09	Screw	Wrench	Handle	BIT
Description	TP093510-GS	TPWBTP09	DH-H4	DB-TP09
EDP	18000214	18000216	18000189	18000209

Milling - Face Milling - Cutter

Cutters for OFER

Entering Angle : 43°
8 Corner Positive

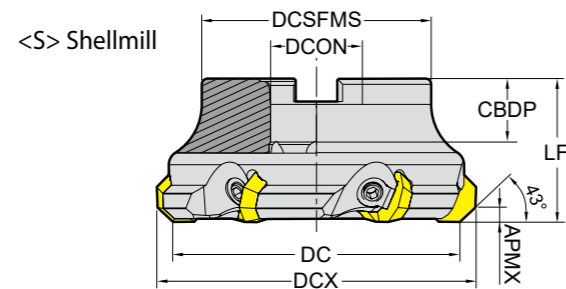

CICT : Number of Inserts
CBDP : Connection Bore Depth

□: p. 156 Unit: mm

Series	APMX	Designation	EDP 1700..	DC	DCX	CICT	LF	TYPE	DCON	CBDP	DCSFMS	PCD1	PCD2	☰
OFER 0704	5.0	F43 - OFER07 - D63Z4S22 - WOC	0484	65	75	4	45	Shellmill	22	22	48	-	-	X
		F43 - OFER07 - D80Z5S27 - WOC	0485	82	92	5	50		27	25	58	-	-	X
		F43 - OFER07 - D100Z6S32 - WOC	0486	102	112	6	50		32	26	80	-	-	X
		F43 - OFER07 - D125Z8S40 - WOC	0487	127	137	8	63		40	32	85	-	-	X
		F43 - OFER07 - D160Z9S40 - WOC	0488	162	172	9	63		40	32	110	66.7	-	X

OFER07	Screw	Wrench	Wedge Clamp
Description	YAKV-15-M8x1x20	YAAL-05-4	YACK-11
EDP	18000086	18000062	18000068

Milling - Face Milling - Cutter

Cutters for ODMT, ODMW

Entering Angle : 43°
8 Corner Positive

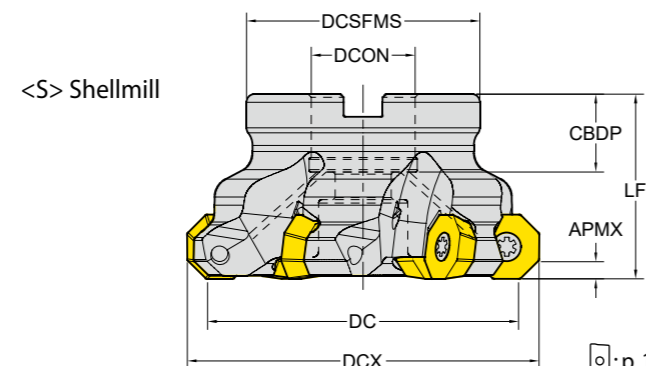

CICT : Number of Inserts
CBDP : Connection Bore Depth

□: p. 155 Unit : mm

Series	APMX	Designation	EDP 1700..	DC	DCX	CICT	LF	TYPE	DCON	CBDP	DCSFMS	PCD1	PCD2	☰
ODMT ODMW 0605	3.5	F43 - ODMT06 - D63Z5S22	0001	63	73	5	40	Shellmill	22	20	50	-	-	●
		F43 - ODMT06 - D80Z6S27	0002	80	90	6	50		27	23	56	-	-	●
		F43 - ODMT06 - D100Z7S32	0003	100	110	7	50		32	26	78	-	-	●
		F43 - ODMT06 - D125Z8S40	0004	125	135	8	63		40	28	89	-	-	●

* Clamping Torque (Nm) 5.3Nm

ODMT06	Screw	Wrench
Description	TP205013	TPWFTP20
EDP	18000007	18000004

Milling - Face Milling - Cutter

Cutters for ONMU

Entering Angle: 45°
16 Corner Negative

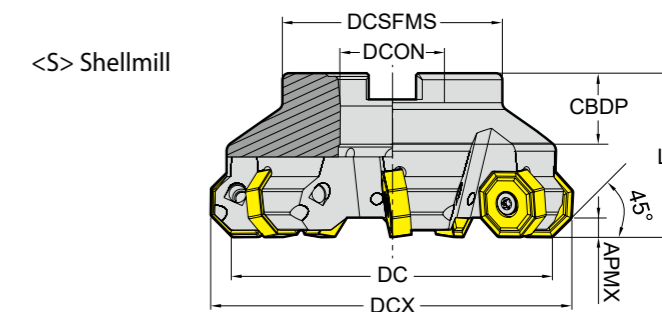

CICT : Number of Inserts
CBDP : Connection Bore Depth

□: p. 157 Unit: mm

Series	APMX	Designation	EDP 1700..	DC	DCX	CICT	LF	TYPE	DCON	CBDP	DCSFMS	PCD1	PCD2	☰
ONMU 0806	5.5	F45 - ONMU08 - D63Z5S22	0493	63	75	5	40	Shellmill	22	22	49	-	-	●
		F45 - ONMU08 - D80Z6S27	0494	80	92	6	50		27	25	58	-	-	●
		F45 - ONMU08 - D100Z7S32	0495	100	112	7	50		32	26	67	-	-	●
		F45 - ONMU08 - D125Z8S40 - WOC	0496	125	137	8	63		40	32	87	-	-	X
		F45 - ONMU08 - D160Z10S40 - WOC	0497	160	172	10	63		40	32	107	66.7	-	X
		F45 - ONMU08 - D200Z12S60 - WOC	0498	200	212	12	63		60	40	130	101.6	-	X
		F45 - ONMU08 - D315Z16S60 - WOC	0499	315	327	16	63		60	40	220	101.6	177.8	X

► ONHU is Available for Wiper Insert

ONMU08	Screw	Wrench
Description	TP205013	TPWFTP20
EDP	18000007	18000004

* Clamping Torque (Nm) 5.3Nm

Milling - Face Milling - Cutter Cutters for PNMU

Entering Angle : 36°
10 Corner Negative

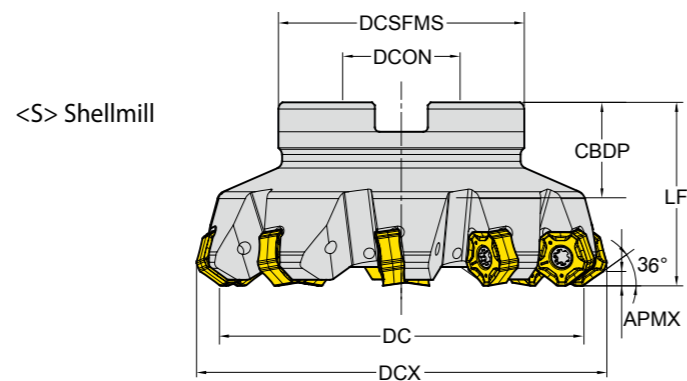

CICT : Number of Inserts
CDBP : Connection Bore Depth

□: p. 158 Unit: mm

Series	APMX	Designation	EDP 1700..	DC	DCX	CICT	LF	TYPE	DCON	CBDP	DCSFMS	PCD1	PCD2	🔴
PNMU 1206	4.0	F36 - PNMU12 - D50Z4S22	0774	50	63.6	4	40	Shellmill	22	20	42	-	-	●
		F36 - PNMU12 - D50Z5S22	0785	50	63.6	5	40		22	20	42	-	-	●
		F36 - PNMU12 - D63Z5S22	0775	63	76.6	5	40		22	20	48	-	-	●
		F36 - PNMU12 - D63Z6S22	0483	63	76.6	6	40		22	20	48	-	-	●
		F36 - PNMU12 - D80Z8S27	0466	80	93.6	8	50		27	23	58	-	-	●
		F36 - PNMU12 - D100Z10S32	0467	100	113.6	10	50		32	26	67	-	-	●
		F36 - PNMU12 - D125Z10S40	0786	125	138.6	10	63		40	29	89	-	-	●

* Clamping Torque (Nm) 3.0Nm

PNMU12	Screw	Wrench	Handle	BIT
Description	TP154008	TPWBTP15	DH-H4	DB-TP15
EDP	18000006	18000217	18000189	18000208

Milling - Profiling - Cutter Cutters for RDKT, RDKW

Round Positive

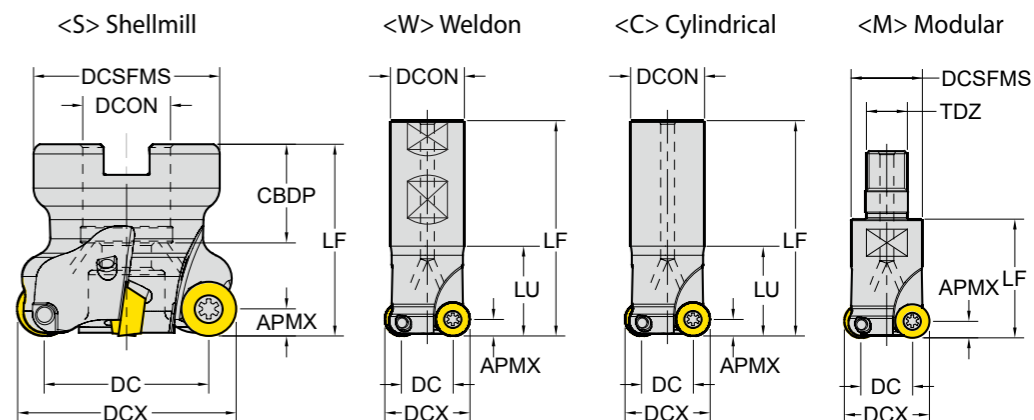

CICT : Number of Inserts
CDBP : Connection Bore Depth

□: p. 159 Unit: mm

Series	APMX	Designation	EDP 1700..	DC	DCX	CICT	LU	LF	TYPE	DCON / TDZ	CBDP	DCSFMS	🔴
RDKT RDKW 0802	4.0	E - RDKT08 - D16Z2C16 - L160	0005	8	16	2	-	160	Cylindrical	16	-	-	●
		E - RDKT08 - D20Z2C20 - L180	0007	12	20	2	-	180		20	-	-	●
		E - RDKT08 - D25Z3C20 - L180	0009	17	25	3	-	180		20	-	-	●
		M - RDKT08 - D16Z2M08	0010	8	16	2	-	23	Modular	M08	-	13	●
		M - RDKT08 - D20Z2M10	0011	12	20	2	-	30		M10	-	18	●
		M - RDKT08 - D25Z3M12	0012	17	25	3	-	35		M12	-	21	●
		E - RDKT10 - D20Z2C20 - L150 - WOC	0576	10	20	2	60	150		Cylindrical	20	-	-
E - RDKT10 - D20Z2C20 - L180	0013	10	20	2	-	180	20	-	-		●		
E - RDKT10 - D25Z2C25 - L150 - WOC	0299	15	25	2	60	150	25	-	-		X		
RDKT RDKW 10T3	5.0	E - RDKT10 - D25Z2C25 - L180	0015	15	25	2	-	180	Weldon	25	-	-	●
		E - RDKT10 - D20Z2W20 - L150 - WOC	0577	10	20	2	60	150		20	-	-	X
		E - RDKT10 - D25Z2W25 - L150 - WOC	0578	15	25	2	60	150		25	-	-	X
		E - RDKT10 - D32Z3W32 - L150 - WOC	0579	22	32	3	60	150	Shellmill	32	-	-	X
		F - RDKT10 - D40Z5S16	0019	30	40	5	-	40		16	18	34	●
		F - RDKT10 - D50Z5S22	0580	40	50	5	-	50		22	22	42	●
		F - RDKT10 - D50Z6S22	0020	40	50	6	-	50		22	22	42	●
		F - RDKT10 - D63Z6S22	0581	53	63	6	-	50	22	22	48	●	
		M - RDKT10 - D20Z2M10	0017	10	20	2	-	30	Modular	M10	-	18	●
		M - RDKT10 - D25Z3M12	0018	15	25	3	-	35		M12	-	21	●

* Clamping Torque (Nm) 1.2Nm

RDKT08	Screw	Wrench
Description	TP082505	TPWFTP08
EDP	18000008	18000002

* Clamping Torque (Nm) 3.0Nm

RDKT10	Screw	Wrench
Description	TP154008RD	TPWFTP15
EDP	18000017	18000003

Milling - Profiling - Cutter

Cutters for RDKT, RDKW

Round Positive

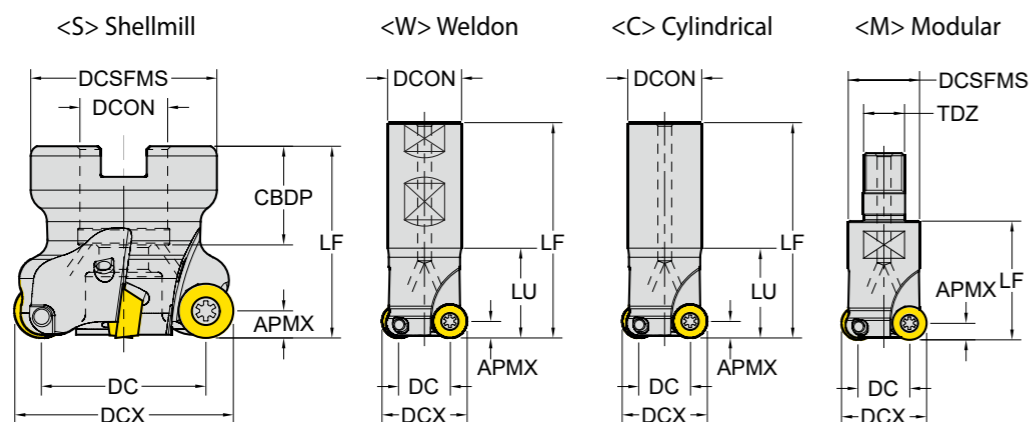

CICT : Number of Inserts
CDBP : Connection Bore Depth

□: p. 159 Unit :mm

Series	APMX	Designation	EDP 1700..	DC	DCX	CICT	LU	LF	TYPE	DCON /TDZ	CDBP	DCSFMS	☉
RDKT RDKW 1204	6.0	E - RDKT12 - D25Z2C25 - L180	0021	13	25	2	80	180	Cylindrical	25	-	-	●
		E - RDKT12 - D32Z2C32 - L200	0023	20	32	2	60	200		32	-	-	●
		E - RDKT12 - D32Z3C32 - L160	0024	20	32	3	60	160		32	-	-	●
		E - RDKT12 - D32Z3C32 - L160 - WOC	0582	20	32	3	70	160		32	-	-	X
		E - RDKT12 - D33Z3C32 - L160 - WOC	0583	21	33	3	70	160		32	-	-	X
		E - RDKT12 - D32Z3W32 - L160 - WOC	0584	20	32	3	50	160	Weldon	32	-	-	X
		F - RDKT12 - D40Z4S16	0028	28	40	4	-	40	Shellmill	16	18	32	●
		F - RDKT12 - D50Z5S22	0029	38	50	5	-	50		22	20	40	●
		F - RDKT12 - D52Z5S22	0585	40	52	5	-	50		22	22	42	●
		F - RDKT12 - D63Z6S22	0030	51	63	6	-	50		22	20	48	●
		F - RDKT12 - D80Z7S27	0586	68	80	7	-	50		27	25	58	●
		F - RDKT12 - D100Z7S32	0587	88	100	7	-	50	32	26	65	●	
		F - RDKT12 - D100Z8S32	0588	88	100	8	-	50	32	26	65	●	
		M - RDKT12 - D25Z2M12	0026	13	25	2	-	35	Modular	M12	-	21	●
		M - RDKT12 - D32Z3M16	0027	20	32	3	-	42		M16	-	29	●
		M - RDKT12 - D42Z4M16	0589	30	42	4	-	43		M16	-	29	●

* Clamping Torque (Nm) 3.0Nm

RDKT12	Screw	Wrench	Wedge Clamp
Description	TP154009	TPWFTP15	MTCA - 130813P
EDP	18000010	18000003	18000037

Milling - High Feed Milling - Cutter

Cutters for SDMT, SDMW

Entering Angle : 10°
4 Corner Positive

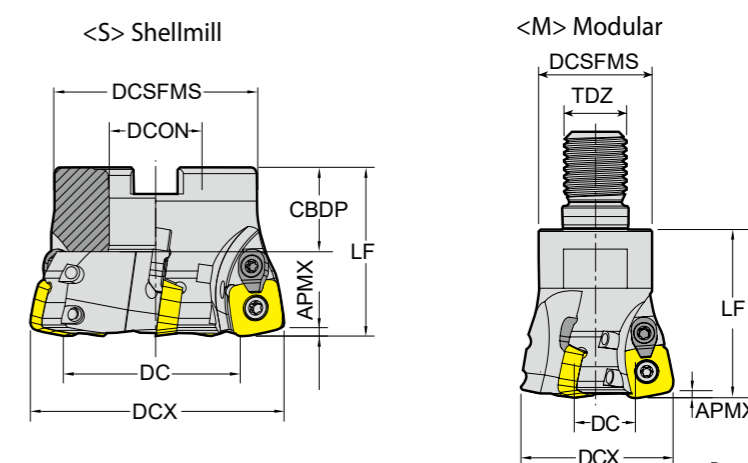

CICT : Number of Inserts
CDBP : Connection Bore Depth

□: p. 163 Unit :mm

Series	APMX	Designation	EDP 1700..	DC	DCX	CICT	LF	TYPE	DCON /TDZ	CDBP	DCSFMS	☉
SDMT SDMW 1204	1.8	FHF - SDMW12 - D50Z4S22	0604	32.4	50	4	40	Shellmill	22	22	42	●
		FHF - SDMW12 - D63Z5S22	0605	45.4	63	5	40		22	22	48	●
		FHF - SDMW12 - D80Z6S27	0606	62.4	80	6	50		27	25	58	●
		FHF - SDMW12 - D100Z8S32	0607	82.4	100	8	50		32	26	65	●
		MHF - SDMW12 - D32Z2M16	0608	14.4	32	2	43	Modular	M16	-	29	●
		MHF - SDMW12 - D40Z3M16	0609	22.4	40	3	43		M16	-	29	●

* Clamping Torque (Nm) 3.0Nm

SDMT12	Screw	Wrench	Handle	Wedge Clamp
Description	Y4015-M4x11	Y80-T15	18000167	YACK-15
EDP	18000119	18000167	-	18000069

Milling - Face Milling - Cutter Cutters for SEGT, SEKT

Entering Angle : 45°
4 Corner Positive

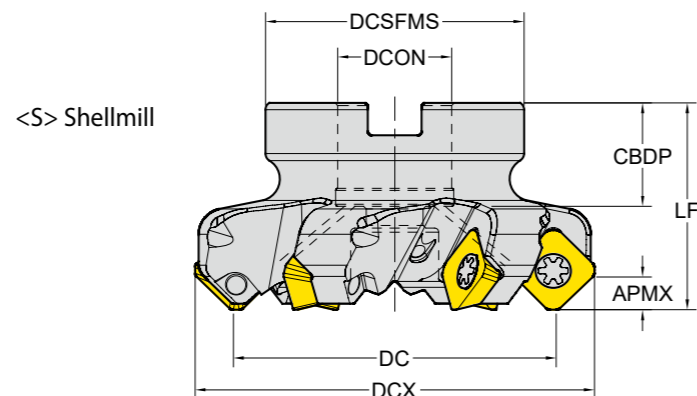

CICT : Number of Inserts
CBDP : Connection Bore Depth

□: p. 164/165 Unit:mm

Series	APMX	Designation	EDP 1700..	DC	DCX	CICT	LF	TYPE	DCON	CBDP	DCSFMS	PCD1	PCD2	☉
SEGT SEKT 12T3	6.0	F45 - SE12T3 - D50Z4S22	0500	50	64	4	40	Shellmill	22	22	48	-	-	●
		F45 - SE12T3 - D63Z5S22	0501	63	77	5	40		22	22	48	-	-	●
		F45 - SE12T3 - D80Z6S27	0502	80	94	6	50		27	25	58	-	-	●
		F45 - SE12T3 - D100Z7S32	0503	100	114	7	50		32	26	65	-	-	●
		F45 - SE12T3 - D125Z8S40 - WOC	0504	125	139	8	63		40	32	85	-	-	X
		F45 - SE12T3 - D160Z10S40 - WOC	0505	160	174	10	63		40	32	110	66.7	-	X
SEGT SEKT 1204	6.0	F45 - SEKT12 - D40Z4S16	0031	40	54	4	40	Shellmill	16	18	32	-	-	●
		F45 - SEKT12 - D50Z5S22	0032	50	64	5	40		22	20	48	-	-	●
		F45 - SEKT12 - D63Z4S22	0033	63	77	4	40		22	20	50	-	-	●
		F45 - SEKT12 - D63Z6S22	0034	63	77	6	40		22	20	50	-	-	●
		F45 - SEKT12 - D80Z4S27	0035	80	94	4	50		27	22	56	-	-	●
		F45 - SEKT12 - D80Z7S27	0036	80	94	7	50		27	22	56	-	-	●
		F45 - SEKT12 - D100Z8S32	0037	100	114	8	50		32	25	78	-	-	●
		F45 - SEKT12 - D125Z10S40	0038	125	139	10	63		40	29	90	-	-	●
		F45 - SEKT12 - D160Z12S40	0039	160	174	12	63		40	30	114	-	-	X

* Clamping Torque (Nm) 2.4Nm

SEKT12T3	Screw	Wrench
Description	Y4015-M3.5x11	Y80-T15
EDP	18000118	18000167
SEKT1204	Screw	Wrench
Description	TP204510	TPWFTP20
EDP	18000011	18000004

Milling - Face Milling - Cutter Cutters for SPCN, SPKN, SPKR

Entering Angle : 75°
4 Corner Positive ISO

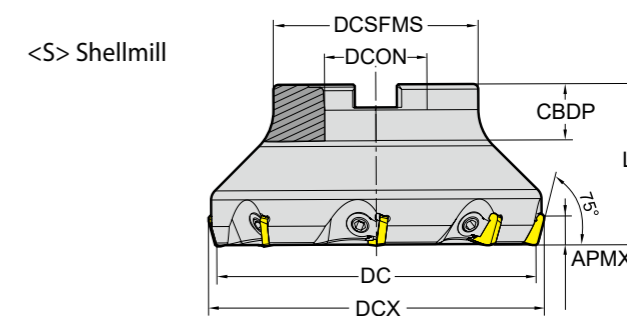

CICT : Number of Inserts
CBDP : Connection Bore Depth

□: p. 169 Unit:mm

Series	APMX	Designation	EDP 1700..	DC	DCX	CICT	LF	TYPE	DCON	CBDP	DCSFMS	PCD1	PCD2	☉
SPCN SPKN SPKR 1203	8.0	F75 - SPKN12 - D50Z4S22 - WOC	0611	50	56	4	42	Shellmill	22	22	42	-	-	X
		F75 - SPKN12 - D63Z5S22 - WOC	0612	63	69	5	40		22	22	48	-	-	X
		F75 - SPKN12 - D80Z6S27 - WOC	0613	80	86	6	50		27	25	58	-	-	X
		F75 - SPKN12 - D100Z7S32 - WOC	0614	100	106	7	50		32	26	65	-	-	X
		F75 - SPKN12 - D125Z8S40 - WOC	0615	125	131	8	63		40	32	80	-	-	X
		F75 - SPKN12 - D160Z9S40 - WOC	0616	160	166	9	63		40	32	110	66.7	-	X
		F75 - SPKN12 - D200Z12S60 - WOC	0617	200	206	12	63		60	40	130	101.6	-	X

SPKN1203	Screw	Wrench	Wedge Clamp
Description	YAKV-22-M8x1x14	YAAL-05-4	YACK-10
EDP	18000089	18000062	18000067
Description	YAKV-13-M8x1x16	-	-
EDP	18000084	-	-

Milling - Face Milling - Cutter Cutters for SNMX

Entering Angle : 45°
8 Corner Negative

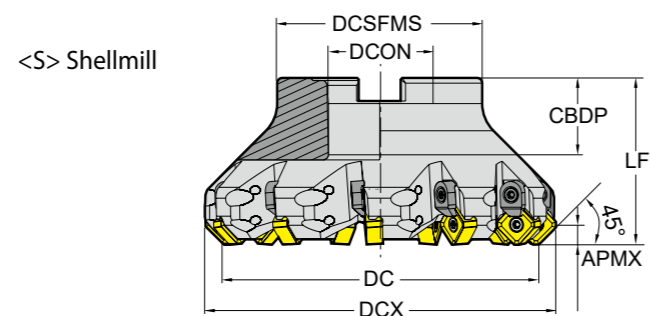

CICT : Number of Inserts
CBDP : Connection Bore Depth

p. 168 Unit:mm

Series	APMX	Designation	EDP 1700..	DC	DCX	CICT	LF	TYPE	DCON	CBDP	DCSFMS	PCD1	PCD2	
SNMX 1206 ANN	6.0	F45 - SNMX12 - D50Z4S22	0506	50	63	4	42	Shellmill	22	22	42	-	-	●
		F45 - SNMX12 - D50Z5S22	0507	50	63	5	42		22	22	42	-	-	●
		F45 - SNMX12 - D63Z6S22	0508	63	76	6	42		22	22	48	-	-	●
		F45 - SNMX12 - D63Z7S22	0509	63	76	7	42		22	22	48	-	-	●
		F45 - SNMX12 - D80Z7S27	0510	80	93	7	52		27	25	58	-	-	●
		F45 - SNMX12 - D80Z8S27	0511	80	93	8	52		27	25	58	-	-	●
		F45 - SNMX12 - D100Z10S32	0512	100	113	10	52		32	26	67	-	-	●
		F45 - SNMX12 - D100Z8S32	0513	100	113	8	52		32	26	67	-	-	●
		F45 - SNMX12 - D125Z11S40 - WOC	0514	125	138	11	65		40	32	80	-	-	X
		F45 - SNMX12 - D160Z12S40 - WOC	0515	160	173	12	65		40	32	110	66.7	-	X
		F45 - SNMX12 - D200Z14S60 - WOC	0516	200	213	14	65		60	40	130	101.6	-	X

* Clamping Torque (Nm) 3.0Nm

SNMX12	Screw	Wrench	Wedge Clamp
Description	Y4015-M4x11	Y80-T15	Y4015-M4x11
EDP	18000119	18000167	18000119

Milling - Shoulder Milling - Cutter Cutters for TPCN, TPKN, TPKR

Entering Angle : 90°
3 Corner Positive ISO

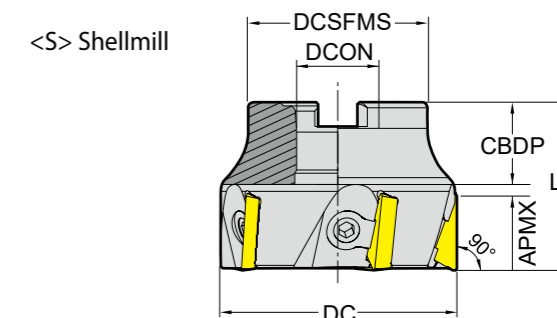

CICT : Number of Inserts
CBDP : Connection Bore Depth

p. 173 Unit:mm

Series	APMX	Designation	EDP 1700..	DC	CICT	LU	LF	TYPE	DCON	CBDP	DCSFMS	PCD1	PCD2	
TPCN TPKN TPKR 1603	12.0	F90 - TPKN16 - D50Z4S22 - WOC	0618	50	4	-	40	Shellmill	22	22	42	-	-	X
		F90 - TPKN16 - D63Z6S22 - WOC	0619	63	6	-	45		22	22	48	-	-	X
		F90 - TPKN16 - D80Z7S27 - WOC	0620	80	7	-	50		27	25	58	-	-	X
		F90 - TPKN16 - D125Z8S40 - WOC	0621	125	8	-	63		40	32	80	-	-	X
TPCN TPKN TPKR 2204	18.0	F90 - TPKN22 - D63Z5S22 - WOC	0622	63	5	-	45	Shellmill	22	22	48	-	-	X
		F90 - TPKN22 - D80Z6S27 - WOC	0623	80	6	-	50		27	25	58	-	-	X
		F90 - TPKN22 - D100Z7S32 - WOC	0624	100	7	-	50		32	26	65	-	-	X
		F90 - TPKN22 - D125Z8S40 - WOC	0625	125	8	-	63		40	32	80	-	-	X
		F90 - TPKN22 - D160Z9S40 - WOC	0626	160	9	-	63		40	32	110	66.7	-	X
		F90 - TPKN22 - D200Z12S60 - WOC	0627	200	12	-	63		60	40	130	101.6	-	X
		F90 - TPKN22 - D250Z15S60 - WOC	0628	250	15	-	63		60	40	160	101.6	-	X
		F90 - TPKN22 - D315Z18S60 - WOC	0629	315	18	-	63		60	40	220	101.6	177.8	X

TPKN16	Screw	Wrench	Wedge Clamp
Description	YAKV-13-M8x1x16	YAAL-05-4	YACK-10
EDP	18000084	18000062	18000067

TPKN22	Screw	Wrench	Wedge Clamp
Description	YAKV-14-M8x1x18	YAAL-05-4	YACK-11
EDP	18000085	18000062	18000068

Milling - Shoulder Milling - Cutter Cutters for TPKT

Entering Angle : 90°
3 Corner Positive

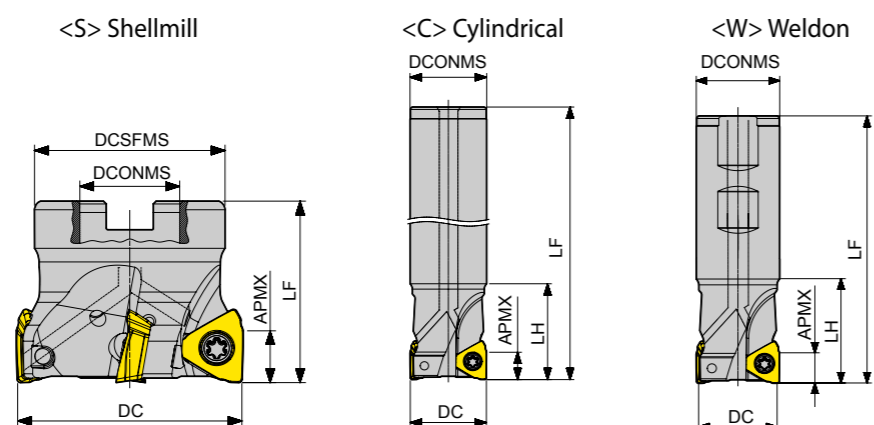

CICT : Number of Inserts
CBDP : Connection Bore Depth

□: p. 172 Unit : mm

Series	APMX	Designation	EDP 1700..	DC	CICT	LF	TYPE	DCON /TDZ	LH	CBDP	DCSFMS	🔴
NEW TPKT 1104	7.0	E90 - TP11 - D20Z2C20 - L170	1037	20	2	170	Cylindrical	20	40	-	-	●
		E90 - TP11 - D21Z2C20 - L150	1038	21	2	150		20	40	-	-	●
		E90 - TP11 - D21Z2C20 - L200	1039	21	2	200		20	40	-	-	●
		E90 - TP11 - D25Z3C25 - L200	1026	25	3	200		25	60	-	-	●
		E90 - TP11 - D26Z2C25 - L200	1041	26	2	200		25	40	-	-	●
		E90 - TP11 - D26Z2C25 - L250	1042	26	2	200		25	40	-	-	●
		E90 - TP11 - D26Z3C25 - L150	1043	26	3	150		25	40	-	-	●
		E90 - TP11 - D26Z3C25 - L200	1044	26	3	200		25	40	-	-	●
		E90 - TP11 - D32Z3C32 - L230	1045	32	3	230		32	60	-	-	●
		E90 - TP11 - D33Z3C32 - L200	1047	33	3	200	32	40	-	-	●	
		E90 - TP11 - D40Z4C32 - L200	1048	40	4	200	32	60	-	-	●	
		E90 - TP11 - D20Z2W20 - L90	0995	20	2	90	Weldon	20	40	-	-	●
		E90 - TP11 - D25Z3W25 - L100	1040	25	3	100		25	40	-	-	●
		E90 - TP11 - D32Z4W32 - L110	1046	32	4	110		32	40	-	-	●
		E90 - TP11 - D40Z5W32 - L115	1049	40	5	115	32	40	-	-	●	
		F90 - TP11 - D40Z5S16	1050	40	5	40	Shellmill	16	-	20	38	●
		F90 - TP11 - D50Z6S22	1051	50	6	40		22	-	20	42	●
		F90 - TP11 - D63Z7S22	1052	63	7	40		22	-	20	48	●
F90 - TP11 - D63Z8S22	1053	63	8	40	22	-		20	48	●		

* Clamping Torque (Nm) 1.2Nm

TPKT1104 (D20, D21)	Screw	Wrench	Handle	BIT
Description	TP082562-GS	TPWBTP08	DH-H4	DB-TP08
EDP	18000265	18000218	18000189	18000190

TPKT1104 (over D25)	Screw	Wrench	Handle	BIT
Description	TP082506-GS	TPWBTP08	DH-H4	DB-TP08
EDP	18000259	18000218	18000189	18000190

Milling - Shoulder Milling - Cutter Cutters for TPKT

Entering Angle : 90°
3 Corner Positive

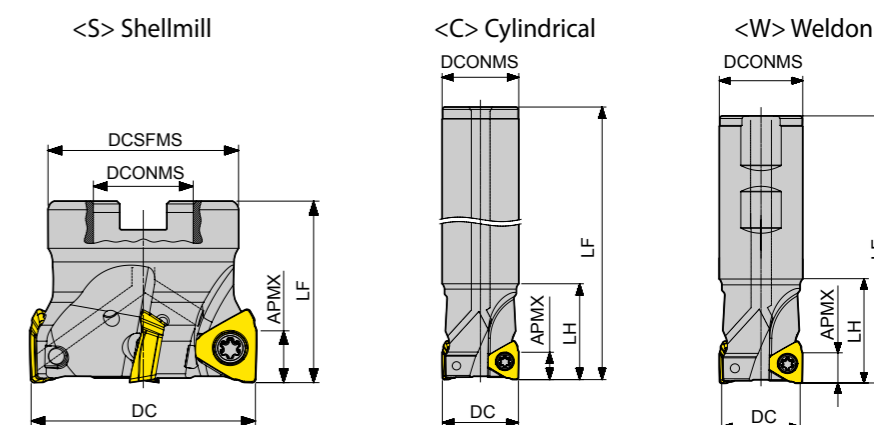

CICT : Number of Inserts
CBDP : Connection Bore Depth

□: p. 172 Unit : mm

Series	APMX	Designation	EDP 1700..	DC	CICT	LF	TYPE	DCON /TDZ	LH	CBDP	DCSFMS	🔴
NEW TPKT 1605	11.0	E90 - TP16 - D32Z2C32 - L150	0941	32	2	150	Cylindrical	32	40	-	-	●
		E90 - TP16 - D32Z2C32 - L250	0942	32	2	250		32	80	-	-	●
		E90 - TP16 - D33Z2C32 - L200	0929	33	2	200		32	40	-	-	●
		E90 - TP16 - D33Z2C32 - L250	1010	33	2	250		32	40	-	-	●
		E90 - TP16 - D40Z4C32 - L200	0945	40	4	200		32	40	-	-	●
		E90 - TP16 - D40Z3W32 - L110	0944	40	3	110	Weldon	32	40	-	-	●
		F90 - TP16 - D50Z4S22	0931	50	4	40	Shellmill	22	-	29	42	●
		F90 - TP16 - D63Z5S22	0932	63	5	40		22	-	29	48	●
		F90 - TP16 - D63Z6S22	0947	63	6	40		22	-	29	48	●
		F90 - TP16 - D80Z6S27	0948	80	6	50		27	-	39	56	●
		F90 - TP16 - D80Z7S27	0949	80	7	50		27	-	39	56	●
		F90 - TP16 - D100Z8S32	0950	100	8	50		32	-	39	67	●
		F90 - TP16 - D125Z10S40	0951	125	10	63		40	-	52	89	●
		F90 - TP16 - D125Z12S40	0952	125	12	63		40	-	52	89	●
		F90 - TP16 - D160Z11S40	0953	160	11	63		40	-	52	110	X
		F90 - TP16 - D200Z11S60	0955	200	11	63		60	-	52	160	X

* Clamping Torque (Nm) 5.3Nm

TPKT1605	Screw	Wrench	Handle	BIT
Description	TP2045105	TPWBTP20	DH-H6	DB-TP20
EDP	18000264	18000256	18000210	18000257

Milling - Shoulder Milling - Cutter Cutters for WNEX

Entering Angle : 90°
6 Corner Negative

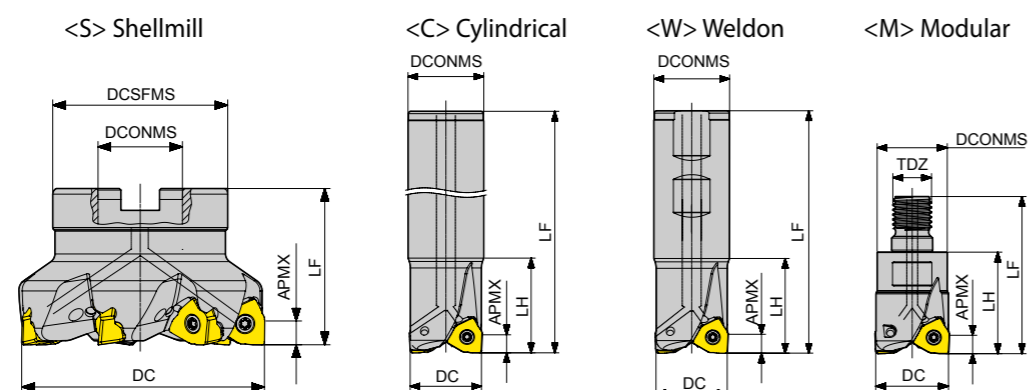

CICT : Number of Inserts
CBDP : Connection Bore Depth

Unit : mm

Series	APMX	Designation	EDP 1700..	DC	CICT	LF	TYPE	DCON /TDZ	LH	CBDP	DCSFMS	🔩	
E90 - WN08 - D32Z2W32 - L120	0969		0969	32	2	120	Weldon	32	40	-	-	●	
E90 - WN08 - D40Z3W32 - L120	0972		0972	40	3	120		32	40	-	-	●	
E90 - WN08 - D40Z4W32 - L120	0973		0973	40	4	120		32	40	-	-	●	
E90 - WN08 - D50Z4W32 - L120	0974		0974	50	4	120		32	40	-	-	●	
E90 - WN08 - D50Z5W32 - L120	0990		0990	50	5	120		32	40	-	-	●	
E90 - WN08 - D32Z2C32 - L120	0991		0991	32	2	120	Cylindrical	32	40	-	-	●	
E90 - WN08 - D32Z2C32 - L200	0872		0872	32	2	200		32	60	-	-	●	
E90 - WN08 - D33Z2C32 - L200	0873		0873	33	2	200		32	40	-	-	●	
E90 - WN08 - D40Z3C32 - L120	0994		0994	40	3	120		32	40	-	-	●	
E90 - WN08 - D40Z3C32 - L200	0874		0874	40	3	200		32	40	-	-	●	
E90 - WN08 - D40Z4C32 - L120	0996		0996	40	4	120		32	40	-	-	●	
E90 - WN08 - D50Z4C32 - L120	0997		0997	50	4	120		32	40	-	-	●	
E90 - WN08 - D50Z5C32 - L120	0998		0998	50	5	120		32	40	-	-	●	
F90 - WN08 - D50Z4S22	0875		0875	50	4	40		Shellmill	22	-	20	44	●
F90 - WN08 - D50Z5S22	0976		0976	50	5	40			22	-	20	44	●
F90 - WN08 - D63Z5S22	0876		0876	63	5	40	22		-	20	48	●	
F90 - WN08 - D63Z6S22	0977		0977	63	6	40	22		-	20	48	●	
F90 - WN08 - D80Z4S27	0999		0999	80	4	50	27		-	20	56	●	
F90 - WN08 - D80Z6S25.4	1000		1000	80	6	50	25.4		-	26.64	56	●	
F90 - WN08 - D80Z7S27	0878		0878	80	7	50	27		-	23	56	●	
F90 - WN08 - D80Z7S25.4	0877		0877	80	7	50	25.4		-	26.64	56	●	
F90 - WN08 - D80Z9S27	0978		0978	80	9	50	27		-	23	56	●	
F90 - WN08 - D100Z8S31.75 - WOC	1002		1002	100	8	50	31.75		-	32	67	X	
F90 - WN08 - D100Z9S32	0979		0979	100	9	50	32		-	26	67	●	
F90 - WN08 - D100Z11S32	0980		0980	100	11	50	32		-	26	67	●	
F90 - WN08 - D125Z10S38.1 - WOC	1003		1003	125	10	63	38.1		-	38	85	X	
F90 - WN08 - D125Z11S40	0981		0981	125	11	63	40		-	29	85	●	
F90 - WN08 - D125Z14S40	0982		0982	125	14	63	40		-	29	85	●	
M90 - WN08 - D32Z2M16	1004		1004	32	2	65	Modular	M16	42	-	29	●	
M90 - WN08 - D40Z3M16	1005		1005	40	3	65		M16	42	-	29	●	
M90 - WN08 - D40Z4M16	0984		0984	40	4	65		M16	42	-	29	●	

* Clamping Torque (Nm) 3.0Nm

WNEX0806	Screw	Wrench	Handle	BIT
Description	TP154011-GS	TPWBTP15	DH-H4	DB-TP15
EDP	18000251	18000217	18000189	18000208

Milling - Modular Shank Modular Shanks

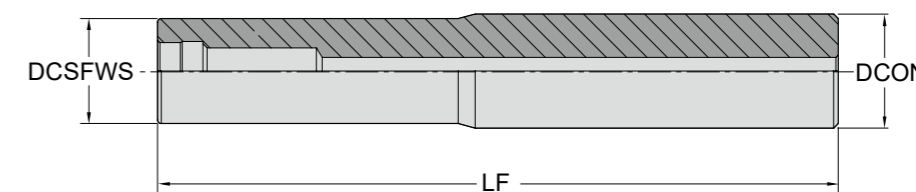

Series	Designation	EDP 1700..	DCSFWS	LF	TYPE	DCON	🔩
M08	EM - M08 - D13C16 - L100	0634	13	100	Cylindrical	16	●
	EM - M08 - D15C16 - L130	0635	15	130		16	●
M10	EM - M10 - D18C20 - L130	0636	18	130	Cylindrical	20	●
M12	EM - M12 - D23C25 - L150	0637	23	150	Cylindrical	25	●
	EM - M12 - D23C25 - L200	0638	23	200		25	●
M16	EM - M12 - D23C25 - L250	0639	23	250	Cylindrical	25	●
	EM - M16 - D30C32 - L150	0640	30	150		32	●
	EM - M16 - D30C32 - L200	0641	30	200		32	●
	EM - M16 - D30C32 - L250	0642	30	250		32	●
	EM - M16 - D30C32 - L300	0643	30	300		32	●

Mounting Bolt

DCON	Description	EDP
Φ16	YHBM08-L20	18000224
Φ16 HF	YHBM08-L25	18000238
Φ22	YHBM10-L25	18000239
Φ22 HF	YHBM10-L30	18000240
Φ25.4 (Metric O.D)	YHBM12-L30	18000241
Φ27	YHBM12-L30	18000241
Φ31.75 (Metric O.D)	YHBM16-L42	18000242
Φ32	YHBM16-L42	18000242
Φ32 HF	YHBM16-L50	18000258
Φ38.1 (Metric O.D)	YHBM20-L54	18000243
Φ40	YHBM20-L54	18000243
Φ0.5" (Φ12.7)	YHBU250-L25.4	18000244
Φ0.75" (Φ19.05)	YHBU375-L25.4	18000245
Φ0.75" (Φ19.05) HF	YHBU375-L31.75	18000246
Φ1.0" (Φ25.4)	YHBU500-L38.1	18000247
Φ1.25" (Φ31.75)	YHBU625-L52	18000248
Φ1.5" (Φ38.1)	YHBU750-L60	18000249
Φ2.0" (Φ50.8)	YHBU1000-L70	18000250



DRILLING

Drilling Overview

Drill Holder

X-Drill Inserts (SYMX)

Square Drill Inserts (SPMX)

Triagonal Drilling Inserts (WCMX)



Scan this QR code to see our X-Drill at work.

Drilling Overview

Drilling Grades

Drilling Grades	P Steel					M Stainless steel					K Cast iron				
	P05	P15	P25	P35	P45	M05	M15	M25	M35	M45	K05	K15	K25	K35	K45
PVD	YG713		713					713					713		
	YG602			602					602					602	
	YG613				613					613					

YG713 P15 - P30 M15 - M30 K15 - K30 H20 - H30	PVD - TiAlN 	Drilling Grade for General Steel Application • Multi-layer TiAlN structure realizes stronger crater and flank wear resistance • Fine-grained carbide and balanced substrate
YG602 P20 - P35 M20 - M40 K20 - K40 S15 - S25	PVD - TiAlN 	Universal grade for General Drilling Application • Ultra Dense PVD Coating with optimal thermal resistance & strength • Sub-Micron substrate designed for demanding application
YG613 P30 - P50 M30 - M50	PVD - TiAlN 	Drilling Grade for Stainless Steel Application • New coating layer with lubrication preventing built-up edge on ultra fine grain substrate with high toughness. • The toughest substrate provides excellent cutting performance in stainless steel

Universal Drilling Inserts

	4 Corner	SYMX Series NEW	SYMX	05, 06, 07, 08
	4 Corner	SPMX Series	SPMX	05, 06, 07, 09, 11, 14
	ISO 3 Corner	WCMX Series	WCMX	03, 04, 05, 06, 08

Drilling Chipbreakers

P	M	K		
	M		-ST	<ul style="list-style-type: none"> • Sharp Geometry • Sticky Material, Stainless Steel
P	M	K	General Inserts (No Description)	<ul style="list-style-type: none"> • First Choice for General Application

Drilling - Inserts
X-Drill Inserts (SYMX)

Recommended Cutting Conditions : p.223

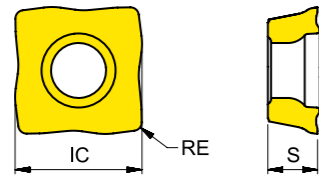

Series	IC	S
SYMX 0502	4.97	2.35
SYMX 0602	5.99	2.35
SYMX 07T2	7.01	2.80
SYMX 0803	8.30	3.20

EDP 3200..

P25	P20	P40
M25	M20	M40
K30	K20	M40

SYMX	Designation	RE (mm)	Fn (mm/rev.)	EDP 3200..		
				YG602	YG713	YG613
	SYMX 050204	0.4	0.06~0.12		●	●
	SYMX 060204	0.4	0.06~0.12		●	●
	SYMX 07T206	0.6	0.06~0.12		●	●
	SYMX 080306	0.6	0.08~0.20		●	●

● : Stock item ○ : Order made item

Drilling - Inserts
Square Drill Inserts (SPMX)

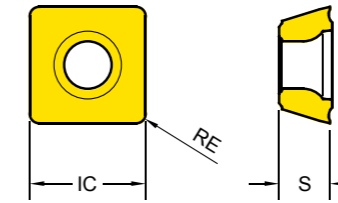

Recommended Cutting Conditions : p.223



Series	IC	S
SPMX 0502	5.00	2.38
SPMX 0602	6.00	2.41
SPMX 07T3	7.94	3.97
SPMX 0904	9.80	4.30
SPMX 1104	11.50	4.80
SPMX 1405	14.30	5.20

EDP 3200..

P25	P20	P40
M25	M20	M40
K30	K20	M40

SPMX	Designation	RE (mm)	Fn (mm/rev.)	EDP 3200..		
				YG602	YG713	YG613
	SPMX 050204	0.4	0.07~0.14	●	●	●
	SPMX 060204	0.4	0.08~0.14	●	●	●
	SPMX 07T308	0.8	0.08~0.16	●	●	●
	SPMX 090408	0.8	0.08~0.16	●	●	●
	SPMX 110408	0.8	0.10~0.18	●	●	●
	SPMX 140512	1.2	0.10~0.20	●	●	●
	SPMX 050204 - ST	0.4	0.03~0.10	●		●
	SPMX 060204 - ST	0.4	0.04~0.11	●		●
	SPMX 07T308 - ST	0.8	0.04~0.11	●		●
	SPMX 090408 - ST	0.8	0.05~0.12	●		●
	SPMX 110408 - ST	0.8	0.05~0.12			●
	SPMX 140512 - ST	1.2	0.05~0.16			●

● : Stock item ○ : Order made item

Triagonal Drill Inserts (WCMX)

Recommended Cutting Conditions : p.223

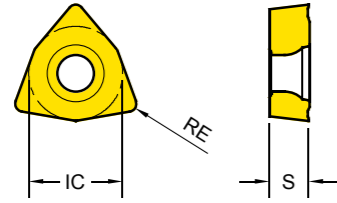

Series	IC	S
WCMX 0302	5.56	2.38
WCMX 0402	6.35	2.38
WCMX 0503	7.94	3.18
WCMX 06T3	9.53	3.97
WCMX 0804	12.70	4.76

EDP 3200..

P25	P20	P40
M25	M20	M40
K30	K20	M40

WCMX	Designation	RE (mm)	Fn (mm/rev.)	YG602	YG713	YG613
General	WCMX 030208	0.8	0.05~0.12	●	●	
	WCMX 040208	0.8	0.05~0.12	●	●	
	WCMX 050308	0.8	0.06~0.14	●	●	
	WCMX 06T308	0.8	0.08~0.14	●	●	
	WCMX 080412	1.2	0.08~0.14	●	●	●

● : Stock item ○ : Order made item

X-Drill Holder (SYMX05) (DC 14~16)

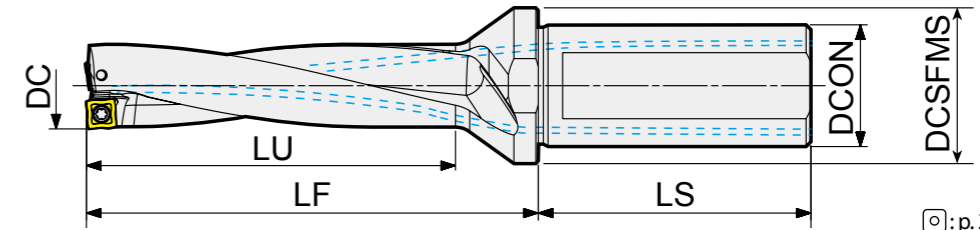

Unit:mm

Series	DC	LU	Designation	EDP 3700..	LF	OAL	DCON	DCSFMS	LS
14	28		YGSY2 - 140S20 - 05	1019	46	96.0	20	25	50
	42		YGSY3 - 140S20 - 05	1031	60	110.0			
	56		YGSY4 - 140S20 - 05	1043	74	124.0			
	70		YGSY5 - 140S20 - 05	1055	88	138.0			
15	30		YGSY2 - 150S20 - 05	1020	49	99.0			
	45		YGSY3 - 150S20 - 05	1032	64	114.0			
	60		YGSY4 - 150S20 - 05	1044	79	129.0			
	75		YGSY5 - 150S20 - 05	1056	94	144.0			
	32		YGSY2 - 160S25 - 05	1021	52	102.0			
16	48		YGSY3 - 160S20 - 05	1033	68	118.0			
	64		YGSY4 - 160S20 - 05	1045	84	134.0			
	80		YGSY5 - 160S20 - 05	1057	100	150.0			

NEW
SYM
050204

PLUG (DCON20)

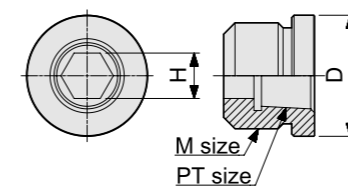

Designation	EDP No.	DCON	ØD	M size	PT size	H
PLUG M12-1/8	38000001	20	14	M12x1.0	PT 1/8	6

* Plug for turning lathe should be ordered separately.

* Clamping Torque (Nm) 0.6Nm

SYMX05	Screw	Wrench
Description	TP062004-GS	TPWFTP06
EDP	18000252	18000262

Plug	DCON	Ø 20	Ø 25	Ø 32
	Description	PLUG M12-1/8	PLUG M14-1/8	PLUG M22-1/4
EDP	38000001	38000002	38000003	

Drilling - Drill Holder
X-Drill Holder (SYM06) (DC 17~20)

Drilling - Drill Holder
X-Drill Holder (SYM07) (DC 21~23)

NEW

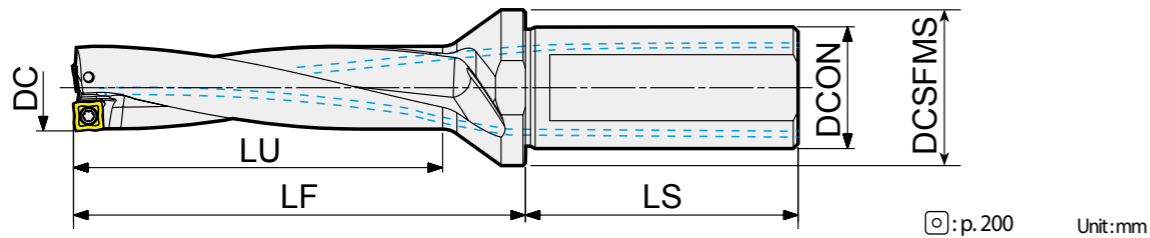

☐: p.200 Unit:mm

Series	DC	LU	Designation	EDP 3700..	LF	OAL	DCON	DCSFMS	LS			
NEW SYM06 060204	17	34	YGSY2 - 170S25 - 06	0851	54	110.0	25	32	56			
		51	YGSY3 - 170S25 - 06	0855	71	127.0						
		68	YGSY4 - 170S25 - 06	0859	88	144.0						
		85	YGSY5 - 170S25 - 06	0863	105	161.0						
18	36	YGSY2 - 180S25 - 06	0852	57	113.0							
	54	YGSY3 - 180S25 - 06	0856	75	131.0							
	72	YGSY4 - 180S25 - 06	0860	93	149.0							
	90	YGSY5 - 180S25 - 06	0864	111	167.0							
19	38	YGSY2 - 190S25 - 06	0853	59	115.0							
	57	YGSY3 - 190S25 - 06	0857	78	134.0							
	76	YGSY4 - 190S25 - 06	0861	97	153.0							
20	95	YGSY5 - 190S25 - 06	0865	116	172.0							
	40	YGSY2 - 200S25 - 06	0854	63	119.0							
	60	YGSY3 - 200S25 - 06	0858	83	139.0							
	80	YGSY4 - 200S25 - 06	0862	103	159.0							
		100	YGSY5 - 200S25 - 06	0866	123	179.0						

PLUG (DCON25)

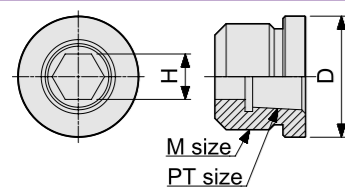

Designation	EDP No.	DCON	ØD	M size	PT size	H
PLUG M14-1/8	38000002	25	16	M14x1.0	PT 1/8	6

* Plug for turning lathe should be ordered separately.

* Clamping Torque (Nm) 0.7Nm

SYM06	Screw	Wrench
Description	TP072205-GS	TPWFTP07
EDP	18000253	18000001

Plug	DCON	Ø 20	Ø 25	Ø 32
	Description	PLUG M12-1/8	PLUG M14-1/8	PLUG M22-1/4
EDP	38000001	38000002	38000003	

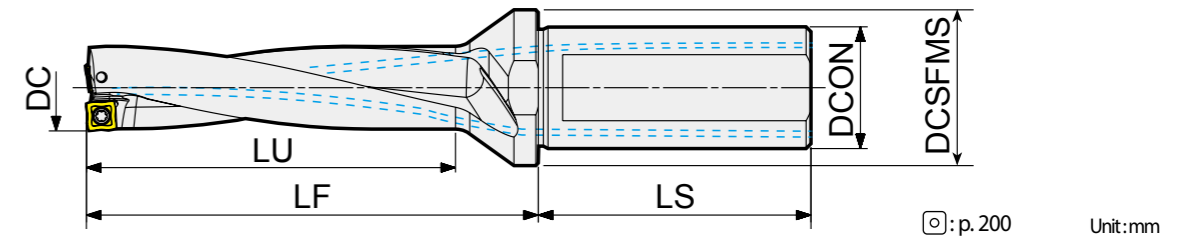

☐: p.200 Unit:mm

Series	DC	LU	Designation	EDP 3700..	LF	OAL	DCON	DCSFMS	LS
NEW SYM07 07T206	21	42	YGSY2 - 210S25 - 07	1022	65	121.0	25	32	56
		63	YGSY3 - 210S25 - 07	1034	86	142.0			
		84	YGSY4 - 210S25 - 07	1046	107	163.0			
		105	YGSY5 - 210S25 - 07	1058	128	184.0			
		44	YGSY2 - 220S25 - 07	1023	67	123.0			
22	66	YGSY3 - 220S25 - 07	1035	89	145.0				
	88	YGSY4 - 220S25 - 07	1047	111	167.0				
	110	YGSY5 - 220S25 - 07	1059	133	189.0				
23	46	YGSY2 - 230S25 - 07	1024	68	124.0				
	69	YGSY3 - 230S25 - 07	1036	91	147.0				
	92	YGSY4 - 230S25 - 07	1048	114	170.0				
	115	YGSY5 - 230S25 - 07	1060	137	193.0				

PLUG (DCON25)

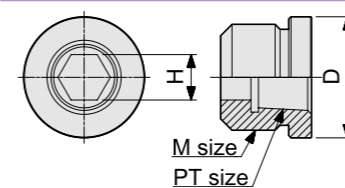

Designation	EDP No.	DCON	ØD	M size	PT size	H
PLUG M14-1/8	38000002	25	16	M14x1.0	PT 1/8	6

* Plug for turning lathe should be ordered separately.

* Clamping Torque (Nm) 0.7Nm

SYM07	Screw	Wrench
Description	TP072205-GS	TPWFTP07
EDP	18000253	18000001

Plug	DCON	Ø 20	Ø 25	Ø 32
	Description	PLUG M12-1/8	PLUG M14-1/8	PLUG M22-1/4
EDP	38000001	38000002	38000003	

X-Drill Holder (SYM08) (DC 24~28)

Square Drill Holder (SPMX05) (DC 13~15)

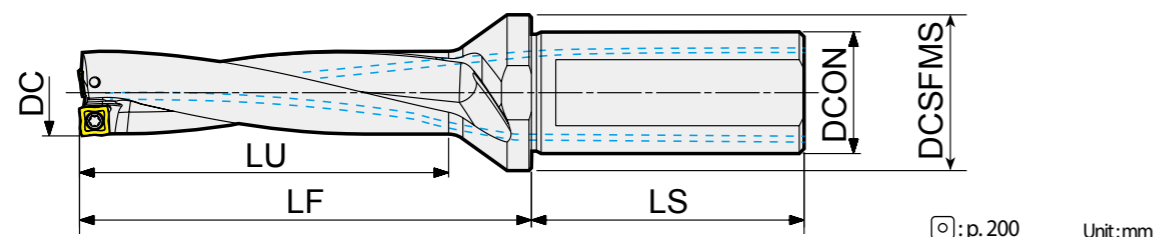

☐: p.200 Unit:mm

Series	DC	LU	Designation	EDP 3700..	LF	OAL	DCON	DCSFMS	LS
24	48		YGSY2 - 240S32 - 08	1025	70	130.0	32	45	60
	72		YGSY3 - 240S32 - 08	1037	94	154.0			
	96		YGSY4 - 240S32 - 08	1049	118	178.0			
	120		YGSY5 - 240S32 - 08	1061	142	202.0			
25	50		YGSY2 - 250S32 - 08	1026	72	132.0			
	75		YGSY3 - 250S32 - 08	1038	97	157.0			
	100		YGSY4 - 250S32 - 08	1050	122	182.0			
	125		YGSY5 - 250S32 - 08	1062	147	207.0			
26	52		YGSY2 - 260S32 - 08	1027	73	133.0			
	78		YGSY3 - 260S32 - 08	1039	99	159.0			
	104		YGSY4 - 260S32 - 08	1051	125	185.0			
27	130		YGSY5 - 260S32 - 08	1063	151	211.0			
	54		YGSY2 - 270S32 - 08	1028	77	137.0			
	81		YGSY3 - 270S32 - 08	1040	104	164.0			
28	108		YGSY4 - 270S32 - 08	1052	131	191.0			
	135		YGSY5 - 270S32 - 08	1064	158	218.0			
	56		YGSY2 - 280S32 - 08	1029	79	139.0			
28	84		YGSY3 - 280S32 - 08	1041	107	167.0			
	112		YGSY4 - 280S32 - 08	1053	135	195.0			
	140		YGSY5 - 280S32 - 08	1065	163	223.0			

NEW
SYM080306

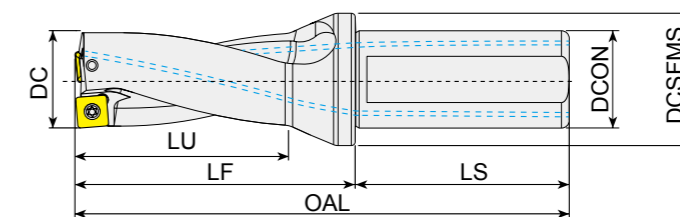

☐: p.201 Unit:mm

Series	DC	LU	Designation	EDP 3700..	LF	OAL	DCON	DCSFMS	LS
SPMX050204	26		YGSP2 - 13S20F026 - 05	0001	44	94	20	25	50
	39		YGSP3 - 13S20F039 - 05	0004	57	107			
	65		YGSP5 - 13S20F065 - 05	0007	83	133			
	28		YGSP2 - 14S20F028 - 05	0002	46	96			
	42		YGSP3 - 14S20F042 - 05	0005	60	110			
	70		YGSP5 - 14S20F070 - 05	0008	88	138			
	30		YGSP2 - 15S20F030 - 05	0003	48	98			
	45		YGSP3 - 15S20F045 - 05	0006	63	113			
	75		YGSP5 - 15S20F075 - 05	0009	93	143			

* Call for us DC size increments of 0.5

PLUG (DCON32)

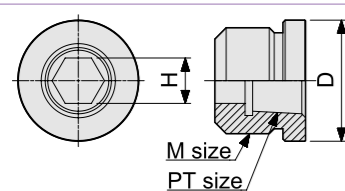

Designation	EDP No.	DCON	ØD	M size	PT size	H
PLUG M22-1/4	38000003	32	24	M22x1.25	PT 1/4	10

* Plug for turning lathe should be ordered separately.

* Clamping Torque (Nm) 1.2Nm

SYM08	Screw	Wrench
Description	TP072506-GS	TPWFTP07
EDP	18000261	18000001

Plug	DCON	Ø 20	Ø 25	Ø 32
	Description	PLUG M12-1/8	PLUG M14-1/8	PLUG M22-1/4
EDP	38000001	38000002	38000003	

* Clamping Torque (Nm) 0.6Nm

SPMX05	Screw	Wrench
Description	T062043D	TWFT06
EDP	18000177	18000031

Square Drill Holder (SPMX06) (DC 16~21)

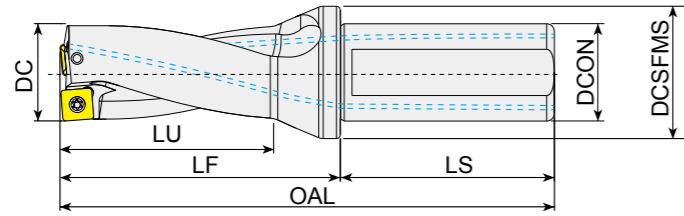

☐: p.201 Unit:mm

Series	DC	LU	Designation	EDP 3700..	LF	OAL	DCON	DCSFMS	LS
SPMX 060204	16	32	YGSP2 - 16S25F032 - 06	0010	53	109	25	32	56
		48	YGSP3 - 16S25F048 - 06	0016	69	125			
		80	YGSP5 - 16S25F080 - 06	0022	101	157			
	17	34	YGSP2 - 17S25F034 - 06	0011	55	111			
		51	YGSP3 - 17S25F051 - 06	0017	72	128			
	18	85	YGSP5 - 17S25F085 - 06	0023	106	162			
		36	YGSP2 - 18S25F036 - 06	0012	57	113			
	19	54	YGSP3 - 18S25F054 - 06	0018	75	131			
		90	YGSP5 - 18S25F090 - 06	0024	111	167			
		38	YGSP2 - 19S25F038 - 06	0013	59	115			
	20	57	YGSP3 - 19S25F057 - 06	0019	78	134			
		95	YGSP5 - 19S25F095 - 06	0025	116	172			
		40	YGSP2 - 20S25F040 - 06	0014	62	118			
	21	60	YGSP3 - 20S25F060 - 06	0020	82	138			
		100	YGSP5 - 20S25F100 - 06	0026	122	178			
		42	YGSP2 - 21S25F042 - 06	0015	64	120			
	21	63	YGSP3 - 21S25F063 - 06	0021	85	141			
		105	YGSP5 - 21S25F105 - 06	0027	127	183			

* Call for us DC size increments of 0.5

* Clamping Torque (Nm) 0.7Nm

SPMX06	Screw	Wrench
Description	T072252D	TWFT07
EDP	18000178	18000032

Square Drill Holder (SPMX07) (DC 22~27)

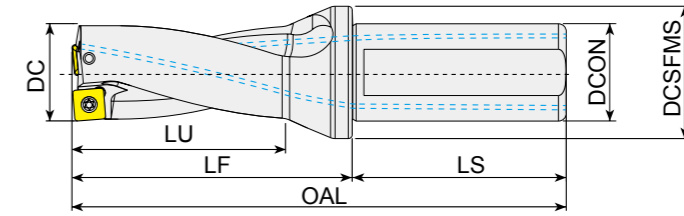

☐: p.201 Unit:mm

Series	DC	LU	Designation	EDP 3700..	LF	OAL	DCON	DCSFMS	LS
SPMX 07T308	22	44	YGSP2 - 22S32F044 - 07	0028	74	134	32	45	60
		66	YGSP3 - 22S32F066 - 07	0034	96	156			
		110	YGSP5 - 22S32F110 - 07	0040	140	200			
	23	46	YGSP2 - 23S32F046 - 07	0029	76	136			
		69	YGSP3 - 23S32F069 - 07	0035	99	159			
	24	115	YGSP5 - 23S32F115 - 07	0041	145	205			
		48	YGSP2 - 24S32F048 - 07	0030	78	138			
	25	72	YGSP3 - 24S32F072 - 07	0036	102	162			
		120	YGSP5 - 24S32F120 - 07	0042	150	210			
		50	YGSP2 - 25S32F050 - 07	0031	80	140			
	26	75	YGSP3 - 25S32F075 - 07	0037	105	165			
		125	YGSP5 - 25S32F125 - 07	0043	155	215			
		52	YGSP2 - 26S32F052 - 07	0032	82	142			
	27	78	YGSP3 - 26S32F078 - 07	0038	108	168			
		130	YGSP5 - 26S32F130 - 07	0044	160	220			
		54	YGSP2 - 27S32F054 - 07	0033	84	144			
	27	81	YGSP3 - 27S32F081 - 07	0039	111	171			
		135	YGSP5 - 27S32F135 - 07	0045	165	225			

* Call for us DC size increments of 0.5

* Clamping Torque (Nm) 1.2Nm

SPMX07	Screw	Wrench
Description	T082564D	TWFT08
EDP	18000179	18000033

Square Drill Holder (SPMX09) (DC 28~33)

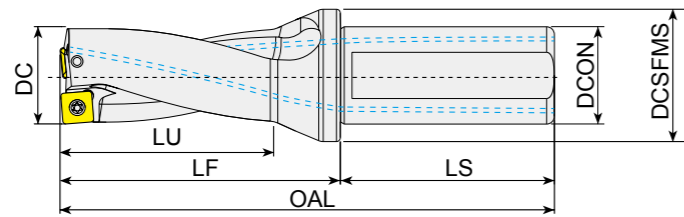

□: p.201 Unit:mm

Series	DC	LU	Designation	EDP 3700..	LF	OAL	DCON	DCSFMS	LS
SPMX 090408	28	56	YGSP2-28S32F056-09	0046	86	146	32	45	60
		84	YGSP3-28S32F084-09	0052	114	174			
		140	YGSP5-28S32F140-09	0058	170	230			
	29	58	YGSP2-29S32F058-09	0047	88	148			
		87	YGSP3-29S32F087-09	0053	117	177			
		145	YGSP5-29S32F145-09	0059	175	235			
	30	60	YGSP2-30S32F060-09	0048	91	151			
		90	YGSP3-30S32F090-09	0054	121	181			
		150	YGSP5-30S32F150-09	0060	181	241			
	31	62	YGSP2-31S32F062-09	0049	93	153			
		93	YGSP3-31S32F093-09	0055	124	184			
	32	155	YGSP5-31S32F155-09	0061	186	246			
		64	YGSP2-32S32F064-09	0050	95	155			
		96	YGSP3-32S32F096-09	0056	127	187			
	33	160	YGSP5-32S32F160-09	0062	191	251			
		66	YGSP2-33S32F066-09	0051	97	157			
99		YGSP3-33S32F099-09	0057	130	190				
	165	YGSP5-33S32F165-09	0063	196	256				

* Call for us DC size increments of 0.5

* Clamping Torque (Nm) 2.4Nm

SPMX09	Screw	Wrench
Description	T103588D	TWFT10
EDP	18000180	18000034

Trigonal Drill Holder (WCMX03) (DC 16~19.5)

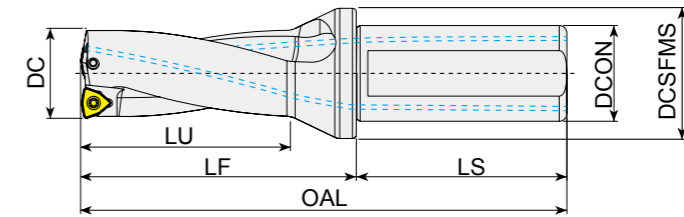

△: p.202 Unit:mm

Series	DC	LU	Designation	EDP 3700..	LF	OAL	DCON	DCSFMS	LS
WCMX 030208	16	32	YGWC2-16S25F032-03	0253	54	110	25	34	56
		48	YGWC3-16S25F048-03	0296	70	126			
		64	YGWC4-16S25F064-03	0339	86	142			
	16.5	32	YGWC2-16.5S25F032-03	0780	54	110			
		48	YGWC3-16.5S25F048-03	0781	70	126			
		64	YGWC4-16.5S25F064-03	0782	86	142			
	17	34	YGWC2-17S25F034-03	0254	56	112			
		51	YGWC3-17S25F051-03	0297	73	129			
		68	YGWC4-17S25F068-03	0340	90	146			
	17.5	34	YGWC2-17.5S25F034-03	0783	56	112			
		51	YGWC3-17.5S25F051-03	0784	73	129			
		68	YGWC4-17.5S25F068-03	0785	90	146			
	18	36	YGWC2-18S25F036-03	0255	58	114			
		54	YGWC3-18S25F054-03	0298	76	132			
		72	YGWC4-18S25F072-03	0341	94	150			
	18.5	36	YGWC2-18.5S25F036-03	0786	58	114			
		54	YGWC3-18.5S25F054-03	0787	76	132			
		72	YGWC4-18.5S25F072-03	0788	94	150			
	19	38	YGWC2-19S25F038-03	0256	60	116			
		57	YGWC3-19S25F057-03	0299	79	135			
		76	YGWC4-19S25F076-03	0342	98	154			
	19.5	38	YGWC2-19.5S25F038-03	0789	60	116			
		57	YGWC3-19.5S25F057-03	0790	79	135			
		76	YGWC4-19.5S25F076-03	0791	98	154			

* Clamping Torque (Nm) 0.6Nm

WCMX03	Screw	Wrench
Description	T0622557	TWFT06
EDP	18000183	18000031

Trigonal Drill Holder (WCMX04) (DC 20~23.5)

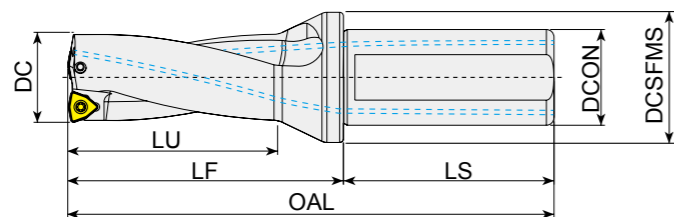

△: p.202 Unit:mm

Series	DC	LU	Designation	EDP 3700..	LF	OAL	DCON	DCSFMS	LS
WCMX 040208	20	40	YGWC2 - 20S25F040 - 04	0257	62	118	25	34	56
		60	YGWC3 - 20S25F060 - 04	0300	82	138			
		80	YGWC4 - 20S25F080 - 04	0343	102	158			
	20.5	40	YGWC2 - 20.5S25F040 - 04	0726	62	118			
		60	YGWC3 - 20.5S25F060 - 04	0727	82	138			
	21	42	YGWC2 - 21S25F042 - 04	0258	64	120			
		63	YGWC3 - 21S25F063 - 04	0301	85	141			
		84	YGWC4 - 21S25F084 - 04	0344	106	162			
	21.5	42	YGWC2 - 21.5S25F042 - 04	0728	64	120			
		63	YGWC3 - 21.5S25F063 - 04	0729	85	141			
	22	44	YGWC2 - 22S25F044 - 04	0259	66	122			
		66	YGWC3 - 22S25F066 - 04	0302	88	144			
		88	YGWC4 - 22S25F088 - 04	0345	110	166			
	22.5	44	YGWC2 - 22.5S25F044 - 04	0730	66	122			
		66	YGWC3 - 22.5S25F066 - 04	0731	88	144			
		88	YGWC4 - 22.5S25F088 - 04	0732	110	166			
	23	46	YGWC2 - 23S25F046 - 04	0260	68	124			
		69	YGWC3 - 23S25F069 - 04	0303	91	147			
		92	YGWC4 - 23S25F092 - 04	0346	114	170			
	23.5	46	YGWC2 - 23.5S25F046 - 04	0733	68	124			
		69	YGWC3 - 23.5S25F069 - 04	0734	91	147			

* Clamping Torque (Nm) 1.2Nm

WCMX04	Screw	Wrench
Description	T072565D	TWFT07
EDP	18000184	18000032

Trigonal Drill Holder (WCMX05) (D2416~29.5)

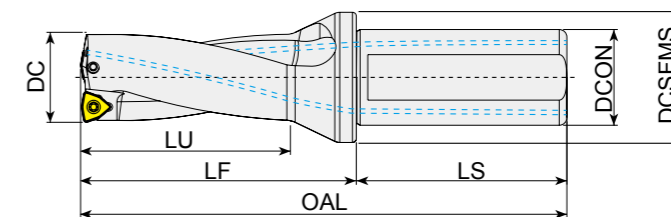

△: p.202 Unit:mm

Series	DC	LU	Designation	EDP 3700..	LF	OAL	DCON	DCSFMS	LS
WCMX 050308	24	48	YGWC2 - 24S25F048 - 05	0261	70	126	25	34	56
		72	YGWC3 - 24S25F072 - 05	0304	94	150			
		96	YGWC4 - 24S25F096 - 05	0347	118	174			
	24.5	48	YGWC2 - 24.5S25F048 - 05	0735	70	126			
		72	YGWC3 - 24.5S25F072 - 05	0736	94	150			
	25	50	YGWC2 - 25S25F050 - 05	0262	72	128			
		75	YGWC3 - 25S25F075 - 05	0305	97	153			
	25.5	100	YGWC4 - 25S25F100 - 05	0251	122	178			
		50	YGWC2 - 25.5S25F050 - 05	0737	72	128			
		75	YGWC3 - 25.5S25F075 - 05	0738	97	153			
	26	52	YGWC2 - 26S25F052 - 05	0263	74	130			
		78	YGWC3 - 26S25F078 - 05	0306	100	156			
		104	YGWC4 - 26S25F104 - 05	0349	126	182			
	26.5	52	YGWC2 - 26.5S25F052 - 05	0739	74	130			
		78	YGWC3 - 26.5S25F078 - 05	0741	100	156			
		104	YGWC4 - 26.5S25F104 - 05	0742	126	182			
	27	54	YGWC2 - 27S25F054 - 05	0264	76	132			
		81	YGWC3 - 27S25F081 - 05	0307	103	159			
	27.5	108	YGWC4 - 27S25F108 - 05	0350	130	186			
		54	YGWC2 - 27.5S25F054 - 05	0743	76	132			
		81	YGWC3 - 27.5S25F081 - 05	0744	103	159			
	28	56	YGWC2 - 28S25F056 - 05	0265	78	134			
		84	YGWC3 - 28S25F084 - 05	0308	106	162			
		112	YGWC4 - 28S25F112 - 05	0351	134	190			
	28.5	56	YGWC2 - 28.5S25F056 - 05	0745	78	134			
		84	YGWC3 - 28.5S25F084 - 05	0746	106	162			
		112	YGWC4 - 28.5S25F112 - 05	0747	134	190			
	29	58	YGWC2 - 29S25F058 - 05	0266	80	136			
		87	YGWC3 - 29S25F087 - 05	0309	109	165			
		116	YGWC4 - 29S25F116 - 05	0352	138	194			
	29.5	58	YGWC2 - 29.5S25F058 - 05	0748	80	136			
		87	YGWC3 - 29.5S25F087 - 05	0749	109	165			

* Clamping Torque (Nm) 1.6Nm

WCMX05	Screw	Wrench
Description	T693072D	TWFT08
EDP	18000185	18000033

Trigonal Drill Holder (WCMX06) (DC 30~44.5)

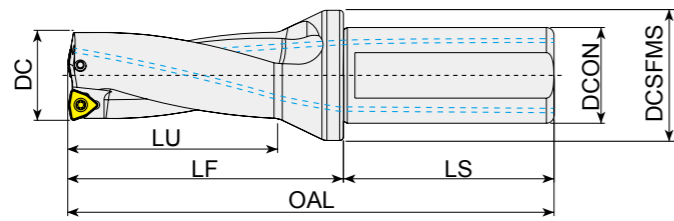

⚠: p.202 Unit:mm

Series	DC	LU	Designation	EDP 3700..	LF	OAL	DCON	DCSFMS	LS
30	60		YGWC2 - 30S32F060 - 06	0267	87	147	32	44	60
	90		YGWC3 - 30S32F090 - 06	0310	117	177			
	120		YGWC4 - 30S32F120 - 06	0353	147	207			
30.5	90		YGWC3 - 30.5S32F090 - 06	0750	117	177			
31	62		YGWC2 - 31S32F062 - 06	0268	89	149			
	93		YGWC3 - 31S32F093 - 06	0311	120	180			
	124		YGWC4 - 31S32F124 - 06	0354	151	211			
31.5	93		YGWC3 - 31.5S32F093 - 06	0751	120	180			
32	64		YGWC2 - 32S32F064 - 06	0269	91	151			
	96		YGWC3 - 32S32F096 - 06	0312	123	183			
	128		YGWC4 - 32S32F128 - 06	0252	155	215			
32.5	96		YGWC3 - 32.5S32F096 - 06	0752	123	183			
33	66		YGWC2 - 33S32F066 - 06	0753	93	153			
	99		YGWC3 - 33S32F099 - 06	0754	126	186			
	132		YGWC4 - 33S32F132 - 06	0755	159	219			
33.5	99		YGWC3 - 33.5S32F099 - 06	0756	126	186			
34	68		YGWC2 - 34S32F068 - 06	0271	95	155			
	102		YGWC3 - 34S32F102 - 06	0314	129	189			
	136		YGWC4 - 34S32F136 - 06	0357	163	223			
34.5	102		YGWC3 - 34.5S32F102 - 06	0758	129	189			
35	70		YGWC2 - 35S32F070 - 06	0272	97	157			
	105		YGWC3 - 35S32F105 - 06	0315	132	192			
	140		YGWC4 - 35S32F140 - 06	0358	167	227			
35.5	105		YGWC3 - 35.5S32F105 - 06	0759	132	192			
36	72		YGWC2 - 36S32F072 - 06	0273	99	159			
	108		YGWC3 - 36S32F108 - 06	0316	135	195			
	144		YGWC4 - 36S32F144 - 06	0359	171	231			
36.5	108		YGWC3 - 36.5S32F108 - 06	0760	135	195			
37	74		YGWC2 - 37S32F074 - 06	0274	101	161			
	111		YGWC3 - 37S32F111 - 06	0317	138	198			
	148		YGWC4 - 37S32F148 - 06	0360	175	235			

▶ NEXT PAGE

* Clamping Torque (Nm) 2.4Nm

WCMX06	Screw	Wrench
Description	T103588D	TWFT10
EDP	18000180	18000034

Trigonal Drill Holder (WCMX06) (DC 30~44.5)

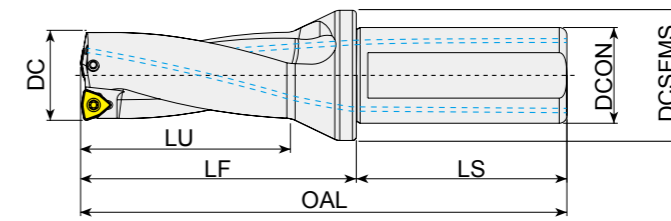

⚠: p.202 Unit:mm

Series	DC	LU	Designation	EDP 3700..	LF	OAL	DCON	DCSFMS	LS
37.5	111		YGWC3 - 37.5S32F111 - 06	0761	138	198	32	44	60
	76		YGWC2 - 38S32F076 - 06	0275	103	163			
38	114		YGWC3 - 38S32F114 - 06	0318	141	201			
38.5	152		YGWC4 - 38S32F152 - 06	0361	179	239			
	114		YGWC3 - 38.5S32F114 - 06	0762	141	201			
39	152		YGWC4 - 38.5S32F152 - 06	0763	179	239			
	78		YGWC2 - 39S32F078 - 06	0276	105	165			
39.5	117		YGWC3 - 39S32F117 - 06	0319	144	204			
	156		YGWC4 - 39S32F156 - 06	0362	183	243			
40	117		YGWC3 - 39.5S32F117 - 06	0764	144	204			
	80		YGWC2 - 40S32F080 - 06	0277	107	167			
40.5	120		YGWC3 - 40S32F120 - 06	0320	147	207			
	160		YGWC4 - 40S32F160 - 06	0363	187	247			
41	120		YGWC3 - 40.5S32F120 - 06	0765	147	207			
	82		YGWC2 - 41S32F082 - 06	0278	109	169			
41.5	123		YGWC3 - 41S32F123 - 06	0321	150	210			
	164		YGWC4 - 41S32F164 - 06	0364	191	251			
42	123		YGWC3 - 41.5S32F123 - 06	0766	150	210			
	84		YGWC2 - 42S32F084 - 06	0279	111	171			
42.5	126		YGWC3 - 42S32F126 - 06	0322	153	213			
	168		YGWC4 - 42S32F168 - 06	0365	195	255			
43	126		YGWC3 - 42.5S32F126 - 06	0767	153	213			
	86		YGWC2 - 43S32F086 - 06	0280	113	173			
43.5	129		YGWC3 - 43S32F129 - 06	0323	156	216			
	172		YGWC4 - 43S32F172 - 06	0366	199	259			
44	129		YGWC3 - 43.5S32F129 - 06	0768	156	216			
	88		YGWC2 - 44S32F088 - 06	0281	115	175			
44.5	132		YGWC3 - 44S32F132 - 06	0324	159	219			
	176		YGWC4 - 44S32F176 - 06	0367	203	263			
44.5	132		YGWC3 - 44.5S32F132 - 06	0769	159	219			

* Clamping Torque (Nm) 2.4Nm

WCMX06	Screw	Wrench
Description	T103588D	TWFT10
EDP	18000180	18000034

Trigonal Drill Holder (WCMX08) (DC 45~60)

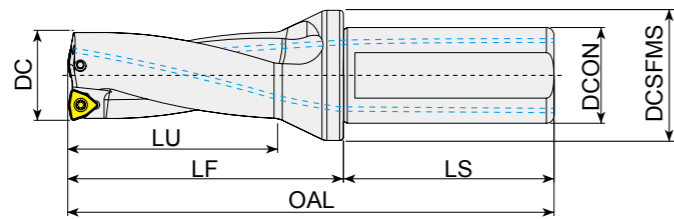

△: p. 202 Unit:mm

Series	DC	LU	Designation	EDP 3700..	LF	OAL	DCON	DCSFMS	LS
WCMX 080412	45	90	YGWC2 - 45S40F090 - 08	0282	122	192	40	54	70
		135	YGWC3 - 45S40F135 - 08	0325	167	237			
		180	YGWC4 - 45S40F180 - 08	0368	212	282			
	45.5	135	YGWC3 - 45.5S40F135 - 08	0770	167	237			
		92	YGWC2 - 46S40F092 - 08	0283	124	194			
	46	138	YGWC3 - 46S40F138 - 08	0326	170	240			
		184	YGWC4 - 46S40F184 - 08	0369	216	286			
		94	YGWC2 - 47S40F094 - 08	0284	126	196			
	47	141	YGWC3 - 47S40F141 - 08	0327	173	243			
		188	YGWC4 - 47S40F188 - 08	0370	220	290			
		96	YGWC2 - 48S40F096 - 08	0285	128	198			
	48	144	YGWC3 - 48S40F144 - 08	0328	176	246			
		192	YGWC4 - 48S40F192 - 08	0371	224	294			
		98	YGWC2 - 49S40F098 - 08	0286	130	200			
	49	147	YGWC3 - 49S40F147 - 08	0329	179	249			
		196	YGWC4 - 49S40F196 - 08	0372	228	298			
		100	YGWC2 - 50S40F100 - 08	0287	132	202			
	50	150	YGWC3 - 50S40F150 - 08	0330	182	252			
		200	YGWC4 - 50S40F200 - 08	0373	232	302			
		102	YGWC2 - 51S40F102 - 08	0288	134	204			
51	153	YGWC3 - 51S40F153 - 08	0331	185	255				

▶ NEXT PAGE

* Clamping Torque (Nm) 3.0Nm

WCMX08	Screw	Wrench
Description	T154011D	TWFT15
EDP	18000186	18000035

Trigonal Drill Holder (WCMX08) (DC 45~60)

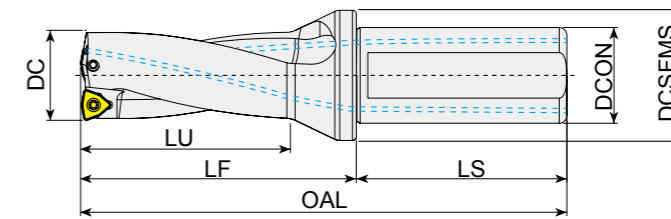

△: p. 202 Unit:mm

Series	DC	LU	Designation	EDP 3700..	LF	OAL	DCON	DCSFMS	LS
WCMX 080412	52	104	YGWC2 - 52S40F104 - 08	0289	136	206	40	54	70
		156	YGWC3 - 52S40F156 - 08	0332	188	258			
	53	106	YGWC2 - 53S40F106 - 08	0290	138	208			
		159	YGWC3 - 53S40F159 - 08	0333	191	261			
	54	108	YGWC2 - 54S40F108 - 08	0291	140	210			
		162	YGWC3 - 54S40F162 - 08	0334	194	264			
	55	110	YGWC2 - 55S40F110 - 08	0292	142	212			
		165	YGWC3 - 55S40F165 - 08	0335	197	267			
	56	112	YGWC2 - 56S40F112 - 08	0293	144	214			
		168	YGWC3 - 56S40F168 - 08	0336	200	270			
	57	114	YGWC2 - 57S40F114 - 08	0294	146	216			
		171	YGWC3 - 57S40F171 - 08	0337	203	273			
	58	116	YGWC2 - 58S40F116 - 08	0295	148	218			
		174	YGWC3 - 58S40F174 - 08	0338	206	276			
	59	118	YGWC2 - 59S40F118 - 08	0771	150	220			
		177	YGWC3 - 59S40F177 - 08	0772	209	279			
	60	120	YGWC2 - 60S40F120 - 08	0773	152	222			
		180	YGWC3 - 60S40F180 - 08	0774	212	282			

* Clamping Torque (Nm) 3.0Nm

WCMX08	Screw	Wrench
Description	T154011D	TWFT15
EDP	18000186	18000035

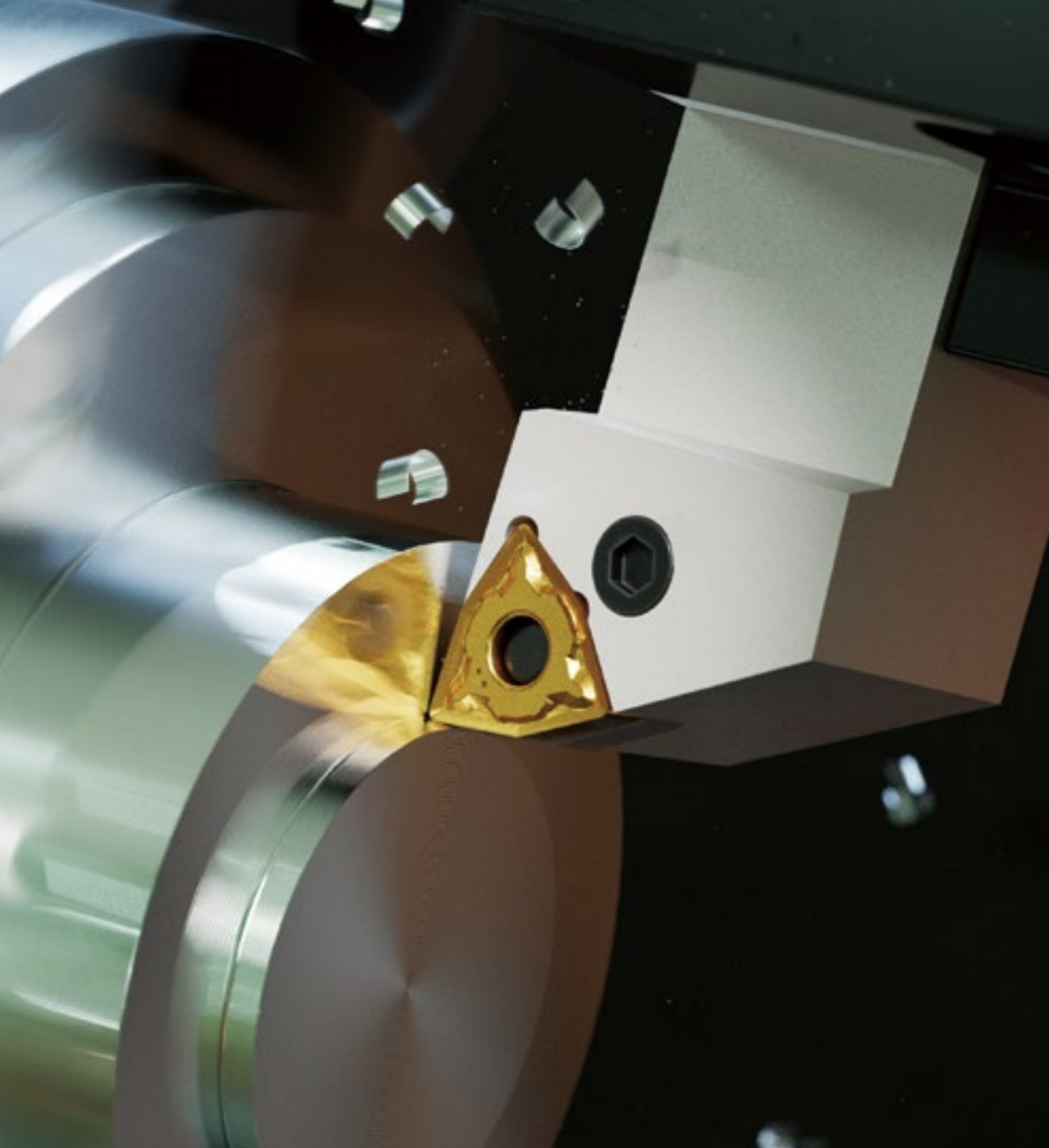

TECHNICAL INFORMATION

- ISO 13399 Terms
- Hardness Conversion Table
- Formulas
- Recommended Cutting Conditions
- Material Groups
- Comparison Chart
- ISO ↔ ANSI
- Search

Technical Information ISO 13399 Terms

AN	Clearance angle major	INSD	Insert diameter
APMX	Maximum depth of cut	KAPR	Tool cutting edge angle
AS	Clearance angle wiper edge	KRINS	Cutting edge angle major
B	Shank width	KWW	Keyway width
BS	Wiper edge length	L	Cutting edge length
CBDP	Connection bore depth	LE	Cutting edge effective length
CDX	Cutting depth maximum	LF	Functional length
CICT	Number of Inserts	LH	Head length
CW	Cutting width	LS	Shank length
CZC	Connection size code	LU	Usable length
DC	Cutting diameter	LUX	Usable length maximum
DCON	Connection diameter	M	Nose (or Wiper) Height
DCSFMS	Contact surface diameter machine side	OAL	Overall length
DCX	Cutting diameter maximum	RE	Corner radius
DMIN	Minimum bore diameter	RMPX	Maximum ramping angle
DMM	Shank diameter	RPMX	Rotational speed maximum
EPSR	Insert included angle	S	Insert thickness
H	Shank height	TDZ	Thread diameter size
HAND	Hand	WF	Functional width
IC	Inscribed circle diameter		

Technical Information

Hardness Conversion Table

HB	HRC	HRB	HV	N/mm ²
199	15	93	199	667
203	16	94	201	680
208	17	95	210	696
212	18	95	218	706
216	19	96	222	716
223	20	97	227	755
229	21	98	235	775
233	22	99	241	794
240	23	100	247	824
245	24	100	252	838
250	25	101	255	853
255	26	102	258	870
262	27	103	262	880
264	28	103	271	892
271	29	104	277	941
277	30	105	285	971
290	31	106	292	990
300	32	107	303	1020
308	33	107	311	1035
314	34	108	320	1049
322	35	108	332	1089
331	36	109	342	1118
341	37	109	351	1157
348	38	110	361	1187
360	39	111	376	1236
373	40	111	388	1265
375	41	112	393	1314
388	42	113	406	1363
402	43	114	424	1390
415	44	114	438	1422
419	45	114	448	1447
430	46	115	458	1471
445	47	115	474	1520
456	48	116	490	1569
468	49	117	497	
469	50	117	505	
486	51	118	531	
504	52	118	549	
513	53	119	567	
534	54	120	589	
552	55		649	
572	56		694	
592	57		727	
601	58		746	
613	59			
627	60			
642	61			
658	62			
681	63			
695	64			
HB	HRC	HRB	HV	N/mm ²

Technical Information

Formulas

Formulas

$$\text{Metric } Vc = D \times RPM \times 0.0031 \text{ (m/min.)} \quad \text{Inch } Vc = D \times RPM \times .262 \text{ (ft/min.)}$$

Cutting Speed (Vc)

$$\text{Metric } Vc \text{ to Inch } Vc \quad \text{Inch } Vc = \text{Metric } Vc \times 3.28 \text{ (ft/min.)}$$

$$\text{Inch } Vc \text{ to Metric } Vc \quad \text{Metric } Vc = \text{Inch } Vc \times .305 \text{ (m/min.)}$$

Turning Formulas

Spindle Speed (RPM)

Metric

$$RPM = Vc \times 318.3 \div D \text{ (rev./min.)}$$

Inch

$$RPM = Vc \times 3.82 \div D \text{ (rev./min.)}$$

Feed Rate (Vf = Table Feed)

$$Vf = Fn \times RPM \text{ (mm/min. or in./min.)}$$

Feed per Revolution (Fn)

$$Fn = Vf \div RPM \text{ (mm/rev. or in./rev.)}$$

Metal Removal Rate (Q)

Metric

$$Q = Vc \times Fn \times Ap \text{ (cm}^3\text{/min.)}$$

Inch

$$Q = Vc \times Fn \times Ap \times 12 \text{ (in}^3\text{/min.)}$$

Cutting Time

$$T = L \div Vf \text{ (min.)}$$

Milling Formulas

Feed per Revolution (Fn)

$$Fn = Vf \div RPM \text{ (mm/rev. or in./rev.)}$$

$$= Fz \times \text{Number of tooth (mm/rev. or in./rev.)}$$

Feed per Tooth (Fz)

$$Fz = Vf \div RPM \div \text{Number of tooth (mm/rev. or in./rev.)}$$

$$= Fn \div \text{Number of tooth (mm/rev. or in./rev.)}$$

Metal Removal Rate (Q)

Metric

$$Q = Ap \times Ae \times Vf \div 1000 \text{ (cm}^3\text{/min.)}$$

Inch

$$Q = Ap \times Ae \times Vf \text{ (in}^3\text{/min.)}$$

Cutting Time

$$T = L \div Vf \text{ (min.)}$$

Power Consumption (Pc)

Metric

$$Pc = Ap \times Ae \times Vf \times Kc \times 0.00000017 \text{ (kW)}$$

Inch

$$Pc = Ap \times Ae \times Vf \times Kc \times 0.00000253 \text{ (Hp)}$$

Drilling Formulas

Power Consumption (Pc)

Metric

$$Pc = Fn \times Vc \times D \times Kc \times 0.0000042 \text{ (kW)}$$

Inch

$$Pc = Fn \times Vc \times D \times Kc \times 0.0000076 \text{ (Hp)}$$

Torque (Mc)

Metric

$$Mc = Pc \times 9554.1 \div RPM \text{ (Nm)}$$

Inch

$$Mc = Pc \times 5255 \div RPM \text{ (lbf ft)}$$

Thrust (T)

$$T \approx 0.5 \times Kc \times DC/2 \times Fn \times \sin KAPR \text{ (N)}$$

Terms

RPM (n)	Spindle Speed (Revolution per minute)
Vc	Cutting Speed
D	Work Diameter
Vf	Feed Rate (Table Feed)
Fn	Feed per Revolution
Ap	Depth of Cut
Q	Metal Removal Rate
L	Length of cut
T	Cutting Time (min.)

Technical Information

Recommended cutting conditions

Turning

Cutting Speed			Vc (m/min.)															
ISO	VDI	Sub Group	YG1010		YG1001		YG3010		YG3015		YG3115		YG3020		YG3030		YG801	
			Min	Max	Min	Max	Min	Max	Min	Max	Min	Max	Min	Max	Min	Max	Min	Max
P	1~5	Non-Alloyed Steel	-	-	220	480	230	450	200	430	180	500	160	380	130	350	120	200
	6~9	Low-Alloyed Steel	-	-	220	420	180	380	150	350	170	450	140	320	130	280	70	200
	10~11	High-Alloyed Steel	-	-	-	-	60	200	90	180	60	300	60	130	70	110	-	-
M	12~13	Ferritic & Martensitic	-	-	-	-	-	-	-	-	-	-	-	-	-	-	-	-
	14	Austenitic Stainless Steel	-	-	-	-	-	-	-	-	-	-	-	-	-	-	-	-
K	15~16	Grey Cast Iron	300	450	250	420	120	300	-	-	-	-	-	-	-	-	-	-
	17~18	Nodular Cast Iron	120	350	120	300	120	280	-	-	-	-	-	-	-	-	-	-
N	21~30	Non-Ferrous Metals (Al)	-	-	-	-	-	-	-	-	-	-	-	-	-	-	-	-
S	31~37	Superalloys & Titanium	-	-	-	-	-	-	-	-	-	-	-	-	-	-	-	-
H	38~41	Hard Materials	-	-	-	-	-	-	-	-	-	-	-	-	-	-	-	-

Turning

Cutting Speed			Vc (m/min.)															
ISO	VDI	Sub Group	YG2025		YG211		YG213		YG214		YG401		YT100		YG100		YG10	
			Min	Max	Min	Max	Min	Max	Min	Max	Min	Max	Min	Max	Min	Max	Min	Max
P	1~5	Non-Alloyed Steel	-	-	-	-	-	-	-	-	-	-	150	480	-	-	-	-
	6~9	Low-Alloyed Steel	-	-	-	-	-	-	-	-	-	-	160	480	-	-	-	-
	10~11	High-Alloyed Steel	-	-	-	-	-	-	-	-	-	-	70	180	-	-	-	-
M	12~13	Ferritic & Martensitic	170	220	170	270	120	180	100	150	-	-	150	280	-	-	-	-
	14	Austenitic Stainless Steel	150	200	150	230	40	160	100	150	-	-	130	260	-	-	-	-
K	15~16	Grey Cast Iron	-	-	-	-	-	-	-	-	-	130	450	-	-	-	-	
	17~18	Nodular Cast Iron	-	-	-	-	-	-	-	-	-	100	400	-	-	-	-	
N	21~30	Non-Ferrous Metals (Al)	-	-	-	-	-	-	-	-	-	-	-	250	1200	250	800	
S	31~37	Superalloys & Titanium	-	-	30	100	30	70	30	50	30	90	-	-	-	-	-	
H	38~41	Hard Materials	-	-	-	-	-	-	-	-	-	-	-	-	-	-	-	

Parting & Grooving

Cutting Speed			Vc (m/min.)			
ISO	VDI	Sub Group	YG602G (YG602)		YG603	
			Min	Max	Min	Max
P	1~5	Non-Alloyed Steel	120	180	-	-
	6~9	Low-Alloyed Steel	100	140	-	-
	10~11	High-Alloyed Steel	80	110	-	-
M	12~13	Ferritic & Martensitic	70	160	50	90
	14	Austenitic Stainless Steel	55	140	40	80
K	15~16	Grey Cast Iron	110	185	-	-
	17~18	Nodular Cast Iron	110	140	-	-
N	21~30	Non-Ferrous Metals (Al)	250	440	-	-
S	31~37	Superalloys & Titanium	25	45	-	-
H	38~41	Hard Materials	25	50	-	-

Technical Information

Recommended cutting conditions

Nanocut

YG812 GRADE			Cutting Speed				Feed per Revolution (Fn)			
ISO	VDI	Sub Group	Vc (m/min.)				Fn (mm/rev.)			
			Min	Max	Min	Max	Min	Max	Min	Max
P	1~5	Non-Alloyed Steel	170	200	0.015	0.025	-	-	-	-
	6~9	Low-Alloyed Steel	95	160	0.015	0.025	-	-	-	-
	10~11	High-Alloyed Steel	85	95	0.015	0.025	-	-	-	-
M	12~13	Ferritic & Martensitic	105	140	0.015	0.025	-	-	-	-
	14	Austenitic Stainless Steel	95	130	0.015	0.025	-	-	-	-
K	15~16	Grey Cast Iron	140	190	0.015	0.025	-	-	-	-
	17~18	Nodular Cast Iron	140	190	0.015	0.025	-	-	-	-
N	21~30	Non-Ferrous Metals (Al)	-	-	-	-	-	-	-	-
S	31~37	Superalloys & Titanium	10	75	0.015	0.025	-	-	-	-
H	38~41	Hard Materials	-	-	-	-	-	-	-	-

Milling

Cutting Speed			Vc (m/min.)																			
ISO	VDI	Sub Group	YG012		YG712		YG713		YG622		YG612		YG602		YG613		YG501(G)		YG5020		YG50	
			Min	Max	Min	Max	Min	Max	Min	Max	Min	Max	Min	Max	Min	Max	Min	Max	Min	Max	Min	Max
P	1~5	Non-Alloyed Steel	180	280	170	300	200	300	140	400	180	280	180	270	100	210	-	-	-	-	-	-
	6~9	Low-Alloyed Steel	150	250	180	250	170	270	120	320	150	250	150	240	70	180	-	-	-	-	-	-
	10~11	High-Alloyed Steel	80	150	100	140	85	145	70	170	70	140	70	130	40	90	-	-	-	-	-	-
M	12~13	Ferritic & Martensitic	-	-	-	-	-	-	-	-	120	200	120	180	70	180	-	-	-	-	-	-
	14	Austenitic Stainless Steel	-	-	-	-	-	-	-	-	130	250	30	230	70	200	-	-	-	-	-	-
K	15~16	Grey Cast Iron	-	-	-	-	-	-	120	270	-	-	120	250	-	-	160	300	200	350	-	-
	17~18	Nodular Cast Iron	-	-	-	-	-	-	130	240	-	-	120	220	-	-	130	210	150	300	-	-
N	21~30	Non-Ferrous Metals (Al)	-	-	-	-	-	-	-	-	-	-	-	-	-	-	-	-	-	-	300	800
S	31~37	Superalloys & Titanium	-	-	-	-	-	-	-	-	25	45	5	45	-	-	-	-	-	-	-	-
H	38~41	Hard Materials	70	120	-	-	-	-	40	100	-	-	-	-	-	-	-	-	-	-	-	-

Drilling

Cutting Speed			Vc (m/min.)							
ISO	VDI	Sub Group	YG602		YG713		YG613			
			Min	Max	Min	Max	Min	Max	Min	Max
P	1~5	Non-Alloyed Steel	180	380	200	300	100	210	-	-
	6~9	Low-Alloyed Steel	120	300	170	270	70	180	-	-
	10~11	High-Alloyed Steel	70	150	85	145	40	90	-	-
M	12~13	Ferritic & Martensitic	120	200	-	-	70	180	-	-
	14	Austenitic Stainless Steel	130	250	-	-	70	200	-	-
K	15~16	Grey Cast Iron	120	250	-	-	-	-	-	-
	17~18	Nodular Cast Iron	130	220	-	-	-	-	-	-
H	38~41	Hard Materials	-	-	-	-	-	-	-	-

Technical Information Material Groups

ISO	VDI 3323	Material Description	Composition / Structure / Heat Treatment	HB	HRC	Examples	
P	1	Non-alloyed steel	About 0.15% C	Annealed	125	S15C, C15, 1015	
	2		About 0.45% C	Annealed	190	13	S45C, C45, 1045
	3		About 0.45% C	Quenched & Tempered	250	25	
	4		About 0.75% C	Annealed	270	28	SK5, CK75, 1080
	5		About 0.75% C	Quenched & Tempered	300	32	
	6	Low-alloyed Steel		Annealed	180	10	SCM440, 42CrMo4, 410
	7			Quenched & Tempered	275	29	
	8			Quenched & Tempered	300	32	
	9			Quenched & Tempered	350	38	
	10	High-alloyed steel, and tool steel		Annealed	200	15	SKD, D2
	11			Quenched & Tempered	325	35	SKH, SUH, M42
M	12	Stainless Steel	Ferritic / Martensitic	Annealed	200	15	SUS 420, X40Cr13, 420
	13		Martensitic	Quenched & Tempered	240	23	
	14		Austenitic		180	10	
K	15	Grey cast iron	Pearlitic / Ferritic		180	10	FC, GG, EN-GJL-250
	16		Pearlitic (Martensitic)		260	26	
	17	Nodular cast iron	Ferritic		160	3	FCD, GGG, EN-GJS-500-7
	18		Pearlitic		250	25	
	19	Malleable cast iron	Ferritic		130		FCMW, FCOMP, GTS, GJMB350-10
20	Pearlitic			230	21		
N	21	Aluminum-wrought alloy	Not Curable		60		SAE 1000, AlMg 1, 3.3315
	22		Curable	Hardened	100		SAE 7050, AlCuMg 1, 3.1325
	23	Aluminum-cast, alloyed	≤ 12% Si, Not Curable		75		ADC12, G-AlSi12, 3.2581
	24		≤ 12% Si, Curable	Hardened	90		C4BS, G-AlSi10Mg, 3.2381
	25		> 12% Si, Not Curable		130		
	26		Cutting Alloys, PB>1%		110		CuZn36Pb 3, 2.0375
	27	Copper and copper alloys (Bronze / Brass)	CuZn, CuSnZn (Brass)		90		CuZn 15, 2.0240
	28		CuSn, lead-free copper and electrolytic copper		100		G-CuZn40Fe, 2.0590
	29	Non-metallic materials	Duroplastic, Fiber Reinforced Plastic				CFRP
	30		Rubber, Wood, etc.				
S	31	Heat resistant super alloys	Fe Based	Annealed	200	15	X12 NiCrSi 36-16, 1.4864
	32			Aged	280	30	
	33			Annealed	250	25	Inconel 718, NiCr20TiAl, 2.4631
	34		Ni or Co Based	Aged	350	38	NiCu30Al, 2.4375
	35			Cast	320	34	G-X120Mn12, 1.3401
36	Titanium alloys	Pure Titanium		400 Rm			
		Alpha + Beta Alloys	Hardened	1050Rm		TiAl6V4, 3.7165	
H	38	Hardened steel		Hardened	550	55	SK3
	39			Hardened	630	60	
	40	Chilled cast iron	Cast	400	42		
	41	Hardened cast iron	Hardened	550	55		

Technical Information Material Groups

Mat'l No.	JIS	DIN	AISI/ASTM/SAE	BS	EN	AFNOR	SS	UNI	UNE / IHA	UNS	GOST	Brands	P	VDI 3323 1	Material Description	Composition / Structure / Heat Treatment	HB	HRC	
															Non-alloyed steel	About 0.15% C, Annealed	125		
1.0037	STKM 12 C	St 37-2	-	4360 40 B	S235JR	E24-2	1311	Fe 360 B											16D
1.0038	STKM 12 A	St 37-3	A570.36	4360 40 C	S275J2G3	E28-3	1312	Fe 360 DFF											ST14KP
1.0045	SM 490 YA	S 355 JR	-	-	S 1207	E36-2	-	Fe 510 BFN											
1.0050	SS 50	St 50-2	A570 Gr. 50	4360 50 B	E 295	A50-2	2172	Fe 490											ST3PS
1.0060	SM 58	St 60-2	A572 Gr. 65	4360 55 E	-	A60-2	1650	Fe 60-2											ST6PS
1.0114		S 235 J0	-	En 40C	S 235 J0	E24-3		Fe 360 CFN											
1.0143		S 275 J0	-	-	S 275 J0	E28-3	1414	Fe 430 C											
1.0144	SM41C, SM400	St 44-3 N	A573 Gr. 81	4360 43C	S 275 J2 G3	E28-3	1412	Fe 430 DFF											ST14KP
1.0149		Ro St 44-2	-	43C	S 275 J0 H	-	1412	Fe430C											
1.0301	S10C	C10	1010	045M10	C10	34C10, XC10		C10	F.1511	G10100	10								
1.0330	SPCC	St 12	-	DC 01	Fe P01	DC 01/Fe P01	1142	Fe P01											15KP
1.0335	SPHE	DD 13 (SW 24)	A622(1008)	H 5.3	DD 13	3C		FeP13											08KP
1.0338	SPCE	St 4	A620(1008)	14491CR	Fe P04	Fe 14	1147	DC04/FeP04											08JU
1.0345	SPV 50	P235 GH	A516 Gr. 65	P 235 GH	P 235 GH	A 37 CP	1330	Fe E 235											K02503
1.0401	S15C	C15	1015	080M15	-	C18RR, XC18	1350	C15, C16	F.1110	G10170	15								
1.0402	S20C	C22	1020	050 A 20	1 C 22	C20	1450	C 20	F.1120	G10200	20								
1.0425	SPV315	P265GH/HII				A42CP	1430	Fe4101KW											K02801
1.0443	SC 450	GS-45	A2765-35	A1		E23-45M	1305												
1.0539		S355NH				TSE355-4	2134	Fe510B											
1.0545		S355N		4360-50E		E355R	2334	FeE355KG											
1.0546		S355NL		4360-50EE		E355FP	2135	FeE355KT											
1.0547		S355J0H		4360-50C		TSE355-3	2172	Fe510C											
1.0549		S355NLH					2135	Fe510D											
1.0553	SM 520 M	S452-3U	A14880-40	4360-50C		320-560M	1606	Fe510C											
1.0562	SM490A	St E 355	A633 Gr. C	P 355 N		FeE355KGN	2132	Fe E 355 KG											K12000
1.0565		W St E 355		P 355 NH		P 355 NH	2106	Fe E 355 KW											K01600
1.0566	SLA 37	T St E 355		P 355 NL1		P 355 NL1	2107	Fe E 355 KT											
1.0570	SM 50 YA	St 52-3	1	4360-50 C	S355JR	E36-3	2172	Fe 510 B											17G15
1.0715	SUM22	95Mn28	1213	230M07		S250	1912	CF5Mn28	F.2111	G12130									
1.0718	SUM22L	95MnPb28	12L13			S250Pb	1914	CF95MnPb28	F.2112	G12134									
1.0721		10S20	1108	10S20		10S20		CF10S20	F.2121	G11080									
1.0722		10SPb20	11L08			10PbF2		CF10SPb20	F.2121	G11084									
1.0736	SUM25	95Mn36	1215			S300		CF9Mn36	F.2113	G12150									
1.0737		95MnPb36	12L14			S300Pb	1926	CF95MnPb36	F.2114	G12144									
1.0972		S315MC		1501-40F30		E315D													
1.0976		S355MC		1501-43F35		E355D	2642	FeE355TM											
1.0982		S460MC		1501-50F45															
1.0984		S500MC				E490D	2662	FeE490TM											
1.0986		S500MC		1501-60F55		E560D		FeE560TM											
1.1121	S10C	CK10	1010	040A10		XC10	1265	C10	F.1510	G10100	10								
1.1141	S15	CK15	1015	040A15	32C	XC15	1370	C15	F.1110	G10150	15								
1.1151	S20C	C22E	1020	055M15		2C22	1450	C20	F.1120	G10230	20								
1.8900	S25C	StE380	A572-60	436055E			2145	FeE390KG											
		St44-2	A36	436043A		NFA35-501E28	1411												
		StE320-3Z		1501160			1421												

Technical Information Material Groups

P	VDI 3323 2		Material Description Non-alloyed steel			Composition / Structure / Heat Treatment About 0.45% C, Annealed					HB 190	HRc 13	
	Mat'l No.	JIS	DIN	AISI/ASTM/SAE	BS	EN	AFNOR	SS	UNI	UNE / IHA	UNS	GOST	Brands
1.0501	S35C	C35	1035	080A32		1C35	1572	C35	F.113	G10350		35	
1.0503	S45C	C45	1045	060A47		XC42H1TS	1672	C45	F.114	G10450		45	
1.0511	S40C	C40	1040	080M40		1C40		C40	F.114.A	G10400		40	
1.0540	S50C	C50					1674	C50		G10500			
1.0551		GS-52	A2770-36	A2		280-480M	1505						
1.0553	SM520M	S152-3U	A14880-40	4360-50C		320-560M	1606	Fe510C					
1.0577		S355J2G4	A738	Fe 510 D 2 FF		A52FP	2107						
1.0726		35520	1140	212M36	8M	35MF6	1957			G11400		40	
1.0727		45520	1146			45MF4	1973			G11460			
1.1157		40Mn4	1039	150M36	15	40M5				G10390		40G	
1.1158	S25C	C25E	1025	070M25		XC25		C25	F.1120	G10250		25	
1.1166	SMn433H	34Mn5	1536						TO.B	G15360			
1.1167	SMn438(H)	36Mn5	1335	150M36		40M5	2120	36Mn6	F.1203	G13350		35G2	
1.1170	SCMn1	28Mn6	1330	150M28	14A	20M5		C28Mn	28Mn6	G13300		30G	
1.1178	S30C	C30E		080M30		XC32		C30	2C30	G10300			
1.1180		C35R	1035	080A35		3C35	1572		F.1135	G10350			
1.1181	S35C	C35E	1035	080A35		XC38	1572	C36	F.1130	G10340		35	
1.1191	S45C	Cl45	1045	080A46		XC45	1672	C45	F.1140			45	
1.1206	S50C	C50E	1050	080M50		2C50	1674	C50		G10500		50	
1.1213	S50C	C53	1050	070M55		XC48HTS	1674	C53		G10500		50	

P	VDI 3323 3		Material Description Non-alloyed steel			Composition / Structure / Heat Treatment About 0.45% C, Annealed					HB 250	HRc 25	
	Mat'l No.	JIS	DIN	AISI/ASTM/SAE	BS	EN	AFNOR	SS	UNI	UNE / IHA	UNS	GOST	Brands
1.0481	SG365	17 Mn 4/P 295 GH	A516 Gr. 70	224-460B	P 295 GH	A 48 CP	2102	Fe E 295	A47RC1	K03501		14G2	
1.0501	S35C	C35	1035	080A32		1C35	1572	C35	F.1130	G10350		35	
1.0503	S45C	C45	1045	060A47		XC42H1TS	1672	C45	F.1140	G10450		45	
1.0614		C76D	1074			XC75				G10750			
1.0616		C86D	1086			XC80		C85		G10860			
1.0618		C92D	1095			XC90				G10950			
1.0726		35520	1140	212M36	8M	35MF6	1957			G11400		40	
1.1157		40Mn4	1039	150M36	15	40M5				G10390		40G	
1.1165	SMn433H	30Mn5	1036	120M36		35M5		30Mn5	F8211	K13300		30G2	
1.1167	SMn438(H)	36Mn5	1335	150M36		40M5	2120	36Mn6	F.1203	G13350		35G2	
1.1186	S40C	C40E	1040	060A40		2C40		C40		G10400			
1.1191	S45C	Cl45	1045	080M46		2C45	1672	C45	F.1140			45	
1.1201	S50C	C45R	1049	080M46		3C45	1660	C45	F.1145			38HM	
1.1213	S50C	C53	1050	070M55		XC48HTS	1674	C53		G10500		50	
1.7242	SCM418 H	18CrMo4											
1.7337		16CrMo4-4	A387 Gr.12			A18CrMo45KW				K11564		15C M	
1.7362	SCM V 6	12CrMo195		3606-625		Z10CD5-05		16CrMo205		K41545			
		17MnV6	A572-60	43605E		NFA35-501E36	2142						

Technical Information Material Groups

P	VDI 3323 4		Material Description Non-alloyed steel			Composition / Structure / Heat Treatment About 0.75% C, Annealed					HB 270	HRc 28	
	Mat'l No.	JIS	DIN	AISI/ASTM/SAE	BS	EN	AFNOR	SS	UNI	UNE / IHA	UNS	GOST	Brands
1.0603	S70C-CSP	C67	107	080A67		XC65		C67		G10700			
1.0605		C75	1075	144980HS				C75		G10740		75	
1.1203	S55C	Cl55	1055	060A57		2C55	1655	C55	F.1150	G10550		55	
1.1209		C55R	1055	070M55		3C55		C55	F.1155	G10550			
1.1221	S58C	Cl60	1060	060A62	43D	2C60	1678	C60	F.1150	G10640		60	
1.1231	S70C-CSP	C67E	1070	060A67		XC68	1770	C70	F.5103	G10700		65GA	
1.1248	C75	C75E	1074	060A78		XC75	1774	C75	F.5107	G10800		75(A)	
1.1269	SK5-CSP	C85E	1086			XC90		C90		G10900		85(A)	
1.1274	SUP4	Cl101	1095	060A96	C1005	XC100	1870	C100	F.5117	G10950			
1.1545	SK3	C105W1	W1	BW2	C105U	Y1105	1880	C100KU	F.5118			U10A	
1.1663	SK2	C125W	W112			Y2120						U13	

P	VDI 3323 5		Material Description Non-alloyed steel			Composition / Structure / Heat Treatment About 0.75% C, Quenched & Tempered					HB 300	HRc 32	
	Mat'l No.	JIS	DIN	AISI/ASTM/SAE	BS	EN	AFNOR	SS	UNI	UNE / IHA	UNS	GOST	Brands
1.0070		St70-2	1055	Fe690-2FN	-	A70-2	1655	Fe690	F.1150			55	
1.0535	S55C	C55	1055	070M55		1C55	1655	C55		J05000		55	
1.0601	S58C	C60	1060	060A62	43D	1C60		C60		G10600		60(G)	
1.1203	S55C	Cl55	1055	060A57		2C55	1655	C55	F.1150	G10550		55	
1.1221	S58C	Cl60	1060	060A62	43D	2C60	1678	C60	F.1150	G10640		60	
1.1274	SUP4	Cl101	1095	060A96	C1005	XC100	1870	C100	F.5117	G10950			
1.1545	SK3	C105W1	W1	BW2	C105U	Y1105	1880	C100KU	F.5118			U10A	
1.1663	SK2	C125W	W112			Y2120						U13	
1.5120		38MnSi4											
1.5710	SNC236	36NiCr6	3135	640A35	111A	35NC6							
1.7701		51CrMoV4						51CrMoV4					

Technical Information Material Groups

Mat'l No.	JIS	DIN	Material Description					Composition / Structure / Heat Treatment					HB	HRC
			Low-alloyed Steel					Annealed						
			AISI/ASTM/SAE	BS	EN	AFNOR	SS	UNI	UNE / IHA	UNS	GOST	Brands		
1.0116		St 37-3	A570 Gr.36	4360-40C	S 235 J2 G3	E24-3	1312	Fe 360 D1(2)	AE235D		ST3KP			
1.0904	SKH 1, SKT 4	55Si7	92S5	250A53	45	55S7	2085	55S8	56S7	G92550	55S2			
1.0961	SUP 7	60SiCr7	9262			60SC6		60SiCr8	60SiCr8	G92620				
1.2067		100Cr6	L3	BL3		Y100C6			100Cr6					
1.2108		90CrSi5	L1				2092	105WCR5						
1.2210		115CrV3	L2				100C3	107CrV3KU	F.520L		11KHF			
1.2241		51CrV4												
1.2330	SCM435TK	35CrMo4	4135	708A37		34CD4	2234	35CrMo4			35KHM			
1.2419	SKS31	105WC6		105WC13		105WC13	2140	10WC6			CWG			
1.2510	SKS3	100MnCrW4	O1	BO1		90MWCV5	2140	95MnWCr5 KU	F.5220		9KHVG			
1.2542		45WCrV7	S1	BS1			2710	45WCrV8KU			5CW25F			
1.2550		60WCrV7	S1			55WC20	2710	58WCr9KU			5KHV25F			
1.2713	SKT4	55NiCrMoV6	L6			55NCDV7			F.520S		5C NM			
1.2721		50NiCr13	L6			55NVC6	2550		F.528					
1.2842		90MnCrV8	O2	BO2		90MV8				T31502	9G2F			
1.3501		100Cr2	E50100											
1.3505	SUJ2	100Cr6	52100	25135	31	100C6	2258	100Cr6	F.1310		SC C 15			
1.5024		46Si7				45S7		46Si7	F.1451					
1.5025		51Si7	9259H		50Si7	51S7	2090	50Si7	F.1450					
1.5026		55Si7			56Si7	55S7	2085	55Si7	F.1440	G92550	55S2			
1.5027		60Si7	9260	251A60	60Si7	60S7		60Si7	F.1441	G92600	60S2			
1.5028	SUP7	65Si7	9260H											
1.5415	STFA 12	15Mo3	A204GrA	1503-243B		15D3	2912	16Mo3(KG)	F.2601	K11820				
1.5419	SCPH11	20Mo4	4419	1503-243-430		2512		G20Mo5		G44190				
1.5423	SB450M	16Mo5	4520	1503-245-420				16Mo5(KG)	F.2602	K11522				
1.5622		14Ni6	A350-LF5			16N6		14Ni6(KG)	F.2641					
1.5732	SNC415(H)	14NiCr10	3415			14NC11		16NiCr11						
1.5752	SNC815(H)	14NiCr14	3310	655M13	36A	12NC15					20X2H4A			
1.6511	SUP10	36CrNiMo4	9840	816M40	110	40NCD3		36NiCrMo4(KB)			40CN2MA			
1.6523	SNCM220(H)	21NiCrMo2	8620	805M20	362	20NCD2	2506	20NiCrMo2			20C GNM			
1.6546	SNCM240	40NiCrMo2-2	8740	311-Tyre7				40NiCrMo2(KB)			38C GNM			
1.6566		17NiCrMo6-4												
1.6587		17CrNiMo6		820A16		18NCD6		14NiCrMo13						
1.6657		10NiCrMo13-4						14NiCrMo131						
1.7015	SCR415(H)	10Cr3	5015	523M15		12C3				G50150	15C			
1.7033	SCR430(H)	34Cr4	5132	530A32	18B	32C4		34Cr4(KB)		G51300	35C			
1.7035	SCR440(H)	41Cr4	5140	530M40	18	42C4	2245	41Cr4		G51400	40H			
1.7131	SCR415	16MnCr5	5115	527M17		16MC5	2511	16MnCr5		G51150	12KHN2			
1.7139		16MnCr5S					2127				18HG			
1.7176	SUP9(A)	55Cr3	5155	527A60	48	55C3	2253	55Cr3			50C GA			
1.7218	SCM420	25CrMo4	4130	CDS110		25CD4	2225	25CrMo4(KB)			20C M			
1.7220	SCM432	34CrMo4	4135	708 A 37		35CD4	2234	34CrMo4			35C M			
1.7223	SNB22-1	41CrMo4	4142					41CrMo4			40C FA			
1.7225	SCM 440 (H)	42CrMo4	4140	708 M 40	42 CrMo 4	42 CD 4	2244	42 CrMo 4	F.1252		38HM			
1.7228		55NiCrMoV6G		823M30	33		2512	653M31						
1.7262	SCM415(H)	15CrMo5				12CD4	2216	12CrMo4						
1.7321		20mOcr4					2625							
1.7335	SCM415(H)	13CrMo4-4	A182-F11	1501-620		15CD4-5	2216	14CrMo45			12C M			
1.7361		32CrMo12		722M24	40B	30CD12	2240	30CrMo12	F.124A					
1.7380		10CrMo9-10	A182F22	1501-622		12CD9-10	2218	12CrMo9			12KH8			

Technical Information Material Groups

Mat'l No.	JIS	DIN	Material Description					Composition / Structure / Heat Treatment					HB	HRC
			Low-alloyed Steel					Annealed						
			AISI/ASTM/SAE	BS	EN	AFNOR	SS	UNI	UNE / IHA	UNS	GOST	Brands		
1.7715		14MoV6-3						1503-660-440			13MoCrV6			
1.8159	SUP 10	50CrV4	6150	735A50	47	50CrV4	2230	50CrV4		G61500	50C GFA			
1.8161		58CrV4												
1.8509	SACM 645	41CrAlMo7	A355A	905M39	41B	40CAD6-12	2940	41CrAlMo7						
1.8523		39CrMoV13-9						897M39	40C		36CrMoV12			

Mat'l No.	JIS	DIN	Material Description					Composition / Structure / Heat Treatment					HB	HRC
			Low-alloyed Steel					Quenched & Tempered						
			AISI/ASTM/SAE	BS	EN	AFNOR	SS	UNI	UNE / IHA	UNS	GOST	Brands		
1.5415	STFA 12	15Mo3	A204GrA	1503-243B		15D3	2912	16Mo3(KG)	F.2601	K11820				
1.5423	SB450M	16Mo5	4520	1503-245-420				16Mo5(KG)	F.2602	K11522				
1.5622		14Ni6	A350-LF5			16N6		14Ni6(KG)	F.2641					
1.5732	SNC415(H)	14NiCr10	3415			14NC11		16NiCr11						
1.5752	SNC815(H)	14NiCr14	3310	655M13	36A	12NC15					20X2H4A			
1.5755	SNC236	31NiCr14	3310	655M13	36A	18NC13	2534		F.1270					
1.6565	SNCM447	40NiCrMo6	4340	817M40	24	35NCD6	2541	35NiCrMo6(KB)			38C 2N2MA			
1.6587		17CrNiMo6		820A16		18NCD6		14NiCrMo13						
1.6657		10NiCrMo13-4						14NiCrMo131						
1.6957		26NiCrMoV14-5												
1.7015	SCR415(H)	10Cr3	5015	523M15		12C3				G50150	15C			
1.7262	SCM415(H)	15CrMo5				12CD4	2216	12CrMo4						
1.7335	SCM415(H)	13CrMo4-4	A182-F11	1501-620		15CD4-5	2216	14CrMo45			12C M			
1.7380		10CrMo9-10	A182F22	1501-622		12CD9-10	2218	12CrMo9			12KH8			
1.7715		14MoV6-3						1503-660-440			13MoCrV6			
1.7733		24CrMoV55				20CDV6		21CrMoV511						
1.7755		GS-45CrMoV10-4												
1.8070		21CrMoV511						35NiCr9						

Mat'l No.	JIS	DIN	Material Description					Composition / Structure / Heat Treatment					HB	HRC
			Low-alloyed Steel					Quenched & tempered						
			AISI/ASTM/SAE	BS	EN	AFNOR	SS	UNI	UNE / IHA	UNS	GOST	Brands		
1.1730		C45W3	C45W								XC48			
1.2332	SCM(440)	47CrMo4	4142	708M40	19A	42CD4	2244	42CrMo4						
1.5736	SNC 631 (H)	36NiCr10	3435			30NC11								
1.6523	SNCM220(H)	21NiCrMo2	8620	805M20	362	20NCD2	2506	20NiCrMo2			20C GNM			
1.7033	SCR430(H)	34Cr4	5132	530A32	18B	32C4		34Cr4(KB)		G51300	35C			
1.7218	SCM420	25CrMo4	4130	CDS110		25CD4	2225	25CrMo4(KB)			20C M			
1.8515		32CrMo12		722M24	40B	30CD12	2240	32CrMo12	F.124A					

Technical Information Material Groups

Mat'l No.	JIS	DIN	Material Description			Composition / Structure / Heat Treatment					HB	HRC	
			AISI/ASTM/SAE	BS	EN	Quenched & Tempered							
1.0904	SKH 1, SKT 4	55Si7	9255	250A53	45	55S7	2085	55Si8		G92550	55S2		
1.0961	SUP 7	60SiCr7	9262			60SC6		60SiCr8		G92620			
1.2067		100Cr6	L3	BL3		Y100C6		100Cr6					
1.2419	SKS31	105WCr6		105WC13		105WC13	2140	10WCr6			CWG		
1.2542		45WCr7	S1	BS1			2710	45WCrV8KU			5CW25F		
1.2713	SKT4	55NiCrMoV6	L6						F5205		5C NM		
1.4882		X50CrMnNiNbN219				Z50CMNNb21-09							
1.5120		38MnSi4											
1.5710	SNC236	36NiCr6	3135	640A35	111A	35NC6							
1.5755	SNC236	31NiCr14		830m31		18NC13	2534		F1270				
1.6511	SUP10	36CrNiMo4	9840	816M40	110	40NCD3		36NiCrMo4(KB)			40C N2MA		
1.6546	SNCM240	40NiCrMo2-2	8740	311-Tyre7				40NiCrMo2(KB)			38C GNM		
1.7035	SCr440(H)	41Cr4	5140	530M40	18	42C4	2245	41Cr4		G51400	40H		
1.7176	SUP9(A)	55Cr3	5155	527A60	48	55C3	2253	55Cr3			50C GA		
1.7220	SCM432	34CrMo4	4135	708Aa37		35CD4	2234	34CrMo4			35C M		
1.7223	SNB22-1	41CrMo4	4142					41CrMo4			40C FA		
1.7225	SCM 440 (H)	42CrMo4	4140	708 M 40	42 CrMo 4	42 CD 4	2244	42 CrMo 4	F1252		38HM		
1.7361		32CrMo12		722M24	40B	30CD12	2240	30CrMo12	F124A				
1.8159	SUP 10	50CrV4	6150	735A50	47	50CrV4	2230	50CrV4	51CrV4	G61500	50C GFA		
1.8161		58CrV4											
1.8509	SACM 645	41CrAlMo7	A355A	905M39	41B	40CAD6-12	2940	41CrAlMo7					
1.8523		39CrMoV13-9		897M39	40C			36CrMoV12					

Mat'l No.	JIS	DIN	Material Description			Composition / Structure / Heat Treatment					HB	HRC	
			AISI/ASTM/SAE	BS	EN	Annealed							
1.0347	SPCD	RRSt 3	A619	CR 3	Fe P03	F 13		DC03/FeP03			08JU		
1.0723	SUM32	15S22		210A15			1922		F210F				
1.2080	SKD1	X210Cr12	D3	BD3	X210Cr12	Z200C12		X205Cr12KU		T30403	KH12		
1.2162	SCR 420 H	21MnCr5				20MCS							
1.2311		40CrMnMo7				40CMD8		35CrMnO8KU					
1.2312		40CrMnMoS8.6	P20+S			40CMD8S							
1.2316		X36CrMo17			X38CrMo16								
1.2343	SKD 6	X38CrMoV5-1	H11	BH11		Z38CDV5		X37CrMoV51KU		T20811	4C 5MFS		
1.2344	SKD61	X40CrMoV5-1	H13	BH13		Z40CDV5	2242	X40CrMoV511KU	F5318	T20813	4C 5MF1S		
1.2363	SKD12	X100CrMoV5-1	A2	BA2		Z100CDV5	2260	X100CrMoV51KU	F5227		9KH5VF		
1.2363	SKD12	X100CrMoV5-1	A2	BA2		Z100CDV5	2260	X100CrMoV51KU	F5227		9KH5VF		
1.2379	SKD11	X155CrVMo121	D2	BD2		Z160CDV12	2310	X165CrMoW12KU		T30402	KH12MF	KRUPP2379	
1.2436	SKD 2	X210CrW12	D4(D6)	BD6		Z200CD12	2312	X215CrW121KU	F5213		KH12		

[NEXT PAGE](#)

Technical Information Material Groups

Mat'l No.	JIS	DIN	Material Description			Composition / Structure / Heat Treatment					HB	HRC	
			AISI/ASTM/SAE	BS	EN	Annealed							
1.2510	SKS3	100MnCrW4	O1	BO1		90MWCV 5	2140	95 MnWCr 5 KU	F5220		9KHVG		
1.2581	SKD5	X30WCrV9-3	H21	BH21		Z30WCV9		X30WCrV93KU	F526	T20821	3C 2W8F		
1.2601		X165CrMoV12					2310	X160CrMoV12			KH12MF		
1.2606	SKD 62	X37CrMoW51	H12	BH12		Z35CWV5		X35CrMoW05KU	F537	T20812	5C NM		
1.2764		X19NiCrMo4											
1.2767		X45NiCrMo4				45NCD16		40NiCrMoV8KU					
1.2842		90MnCrV8	O2	B02		90MV8		90MnVGr8KU		T31502	9G2F		
1.3243	SKH55	S6-5-2-5	T15			KCV06-05-05-04-02	2723	H56-5-2-5			R6M5KS		
1.3249	SKH 3	S18-1-2-5	T4	BT4		Z80WKCV18-05-04					R18K5F2		
1.3343	SKH51, SKH9	S6-5-2	M2	BM2		Z85WDCV	2722	H5652	F5604		R6M5		
1.3348	SKH 58	S2-9-2	M7			Z100DCWV09-04-02	2782	H5292	F5607				
1.3355	SKH2	S18-0-1	T1	BT1		Z80WCV18-4-01					R18		
1.4718	SUH1	X45CrSi9-3	HNV3	401545	52	Z45CS9		X45CrSi8	F322		40C 952		
1.5662	SL9N60(S3)	X8Ni9	ASMA353	502-650		9Ni		X10Ni9	F2645				
1.5680		12Ni19	2515	12Ni19		Z18N5							

Mat'l No.	JIS	DIN	Material Description			Composition / Structure / Heat Treatment					HB	HRC	
			AISI/ASTM/SAE	BS	EN	Quenched & Tempered							
1.2080	SKD1	X210Cr12	D3	BD3	X210Cr12	Z200C12		X205Cr12KU		T30403	KH12		
1.2344	SKD61	X40CrMoV5-1	H13	BH13		Z40CDV5	2242	X40CrMoV511KU	F5318	T20813	4C 5MF1S		
1.2363	SKD12	X100CrMoV5-1	A2	BA2		Z100CDV5	2260	X100CrMoV51KU	F5227		9KH5VF		
1.2436	SKD 2	X210CrW12	D4(D6)	BD6		Z200CD12	2312	X215CrW121KU	F5213		KH12		
1.2581	SKD5	X30WCrV9-3	H21	BH21		Z30WCV9		X30WCrV93KU	F526	T20821	3C 2W8F		
1.2601		X165CrMoV12					2310	X160CrMoV12			KH12MF		
1.2714	SKT 4	55NiCrMoV7	6F3/L6						F5205		5KHNV		
1.3202		S12-1-4-5		BT15				H512-1-5-5					
1.3207		S10-4-3-10		BT42		Z130WKCDV							
1.3243	SKH55	S6-5-2-5	T15			KCV06-05-05-04-02	2723	H56-5-2-5			R6M5KS		
1.3246		S7-4-2-5	M35			Z110WKCDV07-05-04		H57-4-2-5					
1.3247	SKH 51	S2-10-1-8	M42	BM42		Z110DKCW09-08-04		H52-9-1-8			R2AM9KS		
1.3255	SKH 3	S18-1-2-5	T4	BT4		Z80WKCV18-05-04					R18K5F2		
1.3343	SKH51, SKH9	S6-5-2	M2	BM2		Z85WDCV	2722	H5652	F5604		R6M5		
1.3348	SKH 58	S2-9-2	M7			Z100DCWV09-04-02	2782	H5292	F5607				
1.3355	SKH2	S18-0-1	T1	BT1		Z80WCV18-4-01					R18		
1.4718	SUH1	X45CrSi9-3	HNV3	401545	52	Z45CS9		X45CrSi8	F322		40C 952		
1.4935	SUH 616	X20CrMoW121	422							S42200			
1.5680		12Ni19	2515	12Ni19		Z18N5							

Technical Information Material Groups

Mat'l No.	JIS	DIN	Material Description			Composition / Structure / Heat Treatment					HB	HRC
			AISI/ASTM/SAE	BS	EN	AFNOR	SS	UNI	UNE / IHA	UNS		
1.4000	SUS403	X6Cr13	403	403S17		Z6C13	2301	X6Cr13	F3110	S40300	08C 13	ATI 410S
1.4001		X7Cr14	410 S	403S7		Z8C13	2301		F8401		08C 13	
1.4002	SUS 405	X6CrAl13	405	405S17		Z6CA13	2302	X6CrAl13		S40500		
1.4005	SUS416	X12CrS13	416	416S21		Z11CF13	2380	X12CrS13	F3411	S41600		ATI 416
1.4006	SUS410	X12Cr13	410	410S21	56A	Z10C13	2302	X12Cr13	F3401	S41000	12C 13	ATI 410
1.4016	SUS430	X6Cr17	430	430S15	X8Cr17	Z8C17	2320	X8Cr17	F3113	S43000	12C 17	ATI 430
1.4027	SCS 2	GX20Cr14		420C29		Z20C13M					20C 13L	
1.4028	SUS420J2	X30Cr13	420	420S45		Z30C13	2304			S42020	20C 13	
1.4034	SUS420J2	X46Cr13		420S45		Z40C14		X40Cr14	F3405			
1.4057	SUS431	X19CrNi17-2	431	431S29	57	Z15CN16-02	2321	X16CrNi16	F3427	S43100	20C 17N2	431 (HT)
1.4086		GX120Cr29		452C11								
1.4104	SUS430F	X12CrMoS17	430F	420S37		Z10CF17	2383	X10CrS17	F3117	S43020		
1.4112	SUS 440 B	X90CrMoV18	440B							S44003	95KH18	
1.4113	SUS434	X6CrMo17	434	434S17		Z8CD17-01	2325	X8CrMo17		S43400		AL 434
1.4313	SCS5	X3CrNi13-4	CA6-NM	425C11		Z4CND13-04M	2385	(G)X6CrNi304		J91540		
1.4340		GX40CrNi274								J92615		
1.4417		X2CrNiMoS1195	S31500							S39215		
1.4418		X4CrNiMo165				Z6CND16-04-01	2387					APX4
1.4510	SUS430LX	X6CrTi17	XM8			Z4CT17		X6CrTi17	F3115	S43035	08C 17T	430Ti
1.4511	SUS430LK	X6CrNb17				Z4CNb17		X6CrNb17	F3122			AXCS25
1.4512	SUH409	X6CrTi12	409	LW19		Z3CT12		X6CrTi12		S40900		
1.4720		X20CrMo13										
1.4724	SUS 405	X10CrAl13	405	403S17		Z10C13		X10CrAl12	F311		10C 13SJU	
1.4742	SUS430	X10CrAl18	430	439S15	60	Z10CAS18		X8Cr17	F3113	S43000	15C 13SJU	
1.4747	SUH4	X80CrNiSi20	HNW6	443S65	59	Z80CSN20-02		X80CrSiNi20	F3208	S65006		
1.4749		X18CrN28	446								15KH28	
1.4762	SUH446	X10CrAl24	446			Z10CAS24	2322	X16Cr26		S44600		
1.4871	SUH35,SUH36	X53CrMnNiN21-9	EV8	349S54		Z52CMN21-09		X53CrMnNiN219		S63008	55C 20G9AN4	
		X10CrNi15	429									
		X12CrNi18-9	302	302S31		Z10CN18-09	2330					

Mat'l No.	JIS	DIN	Material Description			Composition / Structure / Heat Treatment					HB	HRC
			AISI/ASTM/SAE	BS	EN	AFNOR	SS	UNI	UNE / IHA	UNS		
1.4000	SUS403	X6Cr13	403	403S17		Z6C13	2301	X6Cr13	F3110	S40300	08C 13	ATI 410S
1.4001		X7Cr14	410 S	403S7		Z8C13	2301		F8401		08C 13	
1.4006	SUS410	X12Cr13	410	410S21	56A	Z10C13	2302	X12Cr13	F3401	S41000	12C 13	ATI 410
1.4016	SUS430	X6Cr17	430	430S15	X8Cr17	Z8C17	2320	X8Cr17	F3113	S43000	12C 17	ATI 430
1.4021	SUS 420J1	X20Cr13	420	420S37		Z20C13	2303	14210	F5261	S42000	20C 13	ATI 420
1.4027	SCS 2	GX20Cr14		420C29		Z20C13M					20C 13L	
1.4031	SUS 420 J2	X40Cr13	420			Z40C14	-2304		F3404	S42080	40C 13	
1.4034	SUS420J2	X46Cr13		420S45		Z40C14		X40Cr14	F3405			
1.4057	SUS431	X19CrNi17-2	431	431S29	57	Z15CN16-02	2321	X16CrNi16	F3427	S43100	20C 17N2	431 (HT)
1.4104	SUS430F	X12CrMoS17	430F	420S37		Z10CF17	2383	X10CrS17	F3117	S43020		
1.4113	SUS434	X6CrMo17	434	434S17		Z8CD17-01	2325	X8CrMo17		S43400		AL 434
1.4313	SCS5	X3CrNi13-4	CA6-NM	425C11		Z4CND13-04M	2385	(G)X6CrNi304		J91540		
1.4544		A 700	321	S.524		Z 10 CNT 18 11		X6CrNiTi1811		J92630	08C 18N12T	
1.4546		X5CrNiNb18-10	348	347S31				X6CrNiNb1811		J92640		ATI 348
1.4871	SUH35,SUH36	X53CrMnNiN21-9	EV8	349S54		Z52CMN21-09		X53CrMnNiN219		S63008	55C 20G9AN4	
1.4922		X20CrMoV12-1					2317	x20CrMoV1201				
1.4923		X22CrMoV121										Jethete X20

Technical Information Material Groups

Mat'l No.	JIS	DIN	Material Description			Composition / Structure / Heat Treatment					HB	HRC	
			AISI/ASTM/SAE	BS	EN	AFNOR	SS	UNI	UNE / IHA	UNS			GOST
1.4301	SUS 304	X5CrNi18-10	304	304S15		Z5CN18-09	2332		F3551	S30409	08C 18N10		
1.4305	SUS303	X10CrNiS18-10	303	303S21	58M	Z8CNF18-09	2346	X10CrNiS18.09	F3508	S30300	30C 18N11	ATI 303	
1.4306	SCS19	X2CrNi1911	304L	304C12	X3CrNi1810KD	Z2CN18-09	2352	GX2CrNi1910	F3503	S30403	03KH18N11	ATI 304L	
1.4308	SUS304L	GX6CrNi18-9	CF-8	304C15	58E	Z6CN18-10M	2333					CF-8	
1.4310	SUS 301	X10CrNi18-8	301	301S21		Z12CN17-07	2331	X2CrNi1807	F3517	S30100	07KH16N6	ATI 301	
1.4311	SUS304LN	X2CrNiN18 10	304LN	304S62		Z2CN18-10	2371	X2CrNiN1810	F3541	S30453	03KH18N11		
1.4312	SCS12	GX10CrNi188	305	302C25		Z10CN18-9M					10C 18N9L	ATI 305	
1.4350	SUS304	X5CrNi18-9	304	304S15	58E	Z6CN18-09	2332	X5CrNi1810	F3551	S30400		ATI 304	
1.4362		X2CrNiN234	S32304			Z2CN23-04AZ	2327			S32304		ATI 2304TM	
1.4371		X3CrMnNiN18887	202	284S16		Z8CMN18-08-05							
1.4401	SUS316	X5CrNiMo17-12-2	316	316S13		Z3CND17-11-01	2347	X5CrNiMo17 12 2	F3534	S31600	08KH17H13M2T	ATI 316	
1.4404	SUS316L	X2CrNiMo17-13-2	316L	316S11		Z2CND17-12	2348	X2CrNiMo1712	F3533	S31603		ATI 316L	
1.4406	SUS316LN	X2CrNiMoN17122	316LN	316S61		Z2CND17-12AZ		X2CrNiMoN1712	F3542	S31653	07C 18N	ATI 316LN	
1.4408	SCS14	GX6CrNiMo18-10	CF-8M	316C16			2343	X7CrNiMo2010	F8414	J92900	10G2S2MSL		
1.4410	SCS 14 A	GX10CrNiMo18-9				Z5CND20-12M	2328				S32750		
1.4429	SUS316LN	X2CrNiMoN17-13-3	316Ln	316S62		Z2CND17-13AZ	2375	X2CrNiMoN17133	F3543		03KH16N15M3		
1.4435	SUS316L	X2CrNiMo18143	316L	316S11		Z3CND17-12-03	2375	X2CrNiMo17 13 2	F3533	S31603	03C 17N14M3		
1.4436	SUS316	X3CrNiMo17-13-3	316	316S19		Z6CND18-12-03	2343	X5CrNiMo17 12 2	F3543	S31600			
1.4438	SUS317L	X2CrNiMo18164	317L	317S12		Z2CND19-15-04	2367	X2CrNiMo18 16 4	F3539	S31703		ATI 317L	
1.4439		X2CrNiMoN17135	(s31726)			Z3CND18-14-06AZ							
1.4440		X2CrNiMo18-16											
1.4449	SUS317	X5CrNiMo17133	317	317S16				X5CrNiMo1815		S31700		ATI 317	
1.4460	SUS 329 J1	X8CrNiMo275	329				2324			S32900		10RES1	
1.4462	SUS329J3L	X2CrNiMoN2253		318S13		Z3CND22-05AZ	2377			S31803		ATI 2205TM	
1.4500		X7NiCrMoCuNb2520				Z3NCDU25-20M					J95150		
1.4521	SUS444	X2CrMoTi18-2	443444				2326	X2CrMoTiNb18 2	F3123				
1.4539		X1NiCrMoCuN25205				Z2NCDU25-20	2562			N08904		ATI 904L	
1.4541	SUS321	X14CrNiTi18-10	321	321S31		Z6CNT18-10	2337	X6CrNiTi18 11	F3523	S32100	06C 18N10T	ATI 321	
1.4542	SUS630	X5CrNiCuNb174	630			Z7CNU15-05						UGIMA 4542	
1.4545		Z7CNU15.05	15-SPH								S15500	ATI 15-5	
1.4547		X1CrNiMoN20187	S31254				2378				S31254	Uranus B25 GMo	
1.4550	SUS347	X6CrNiNb18-10	347	347S17	58F	Z6CNNb18-10	2338	X6CrNiNb18 11	F3552	S34700	08C 18N12B	ATI 347	
1.4552	SCS 21	GX7CrNiNb18-9				Z4CNNb19-10M					J92710		
1.4568	SUS 631	X 7 CrNiAl 17 7					316S111			Z 9 CAN 17-7	2388	Z8CNA17-07	S17700 09C 17NUJ1 17-7PH
1.4571	SUS 316Ti	X6CrNiMoTi17-12-2	316Ti	320S31	58J	Z6NDT17-12	2350	X6CrNiMoTi17 12	F3535		10C 17N13M2T	ATI 316Ti	
1.4581	SCS 22	GX5CrNiMoNb18					318C17			Z4CNDNb18-12M			
1.4583		X6CrNiMoNb18-12	318	303S21		Z15CNS20-12		X15CrNiSi2 12					
1.4585		GX7CrNiMoCuNb1818						X6CrNiMoTi17 12			J94651		
1.4821		X20CrNiSi254				Z20CNS25-04					S44635		
1.4823		GX40CrNiSi274									J92605		
1.4828	SCS17	X15CrNiSi20-12	309	309S24	58C	Z15CNS20-12				F8414	S30900	20C 20N14S2	ATI 309
1.4833	SUS 309 S	X6CrNi2213	309S	309S13		Z15CN24-13					J93400		
1.4845	SUH310	X12CrNi25-21	310S	310S24		Z12CN25-20	2361						

Technical Information Material Groups

Mat'l No.	JIS	DIN	Material Description			Composition / Structure / Heat Treatment					HB	HRc
			AISI/ASTM/SAE	BS	EN	AFNOR	SS	UNI	UNE / IHA	UNS		
K VDI 3323 15 Grey cast iron Pearlitic / Ferritic HB 180 HRc 10												
0.6010	FC100	GG10	A48 20 B	Grade 100	GJL-100	Ft 10 D	0100	G10	FG10		Sc 10	
0.6015	FC150	GG15	A48 25 B	Grade 150	GJL-150	Ft 15 D	0115	G15	FG15		Sc 15	
0.6020	FC200	GG20	A48 30 B	Grade 220	GJL-200	Ft 20 D	0120	G20	FG20	W06020	Sc 20	
0.6025	FC250	GG25	A48 40 B	Grade 260	GJL-250	Ft 25 D	0125	G25	FG25		Sc 25	
0.6660		GGL-NiCr 20.2	1050/700/7	Grade F2	GJLA-XNiCr 20-2	L-NC 202	0523	-		F41002	Ni-Resist 2	
1.4449	SUS317	X5CrNiMo17133	317	317S16				X5CrNiMo1815		S31700	ATI 317	

Mat'l No.	JIS	DIN	Material Description			Composition / Structure / Heat Treatment					HB	HRc
			AISI/ASTM/SAE	BS	EN	AFNOR	SS	UNI	UNE / IHA	UNS		
K VDI 3323 16 Grey cast iron Pearlitic (Martensitic) HB 260 HRc 26												
0.6025	FC250	GG25	A48 40 B	Grade 260	GJL-250	Ft 25 D	0125	G25	FG25		Sc 25	
0.6030	FC300	GG30	A48 45 B	Grade 300	GJL-300	Ft 30 D	0130	G30	FG30		Sc 30	
0.6035	FC350	GG35	A48 50 B	Grade 350	GJL-350	Ft 35 D	0135	G35	FG35		Sc 35	
0.6040	FC400	GG40	A48 60 B	Grade 400	GJL-400	Ft 40 D	0140	G40	FC40		Sc 40	

Mat'l No.	JIS	DIN	Material Description			Composition / Structure / Heat Treatment					HB	HRc
			AISI/ASTM/SAE	BS	EN	AFNOR	SS	UNI	UNE / IHA	UNS		
K VDI 3323 17 Nodular cast iron Ferritic HB 160 HRc 3												
0.7033	FCD350-22L	GGG35.3	-	350/22L40	GJS-350-22-LT	FGS 370-17	0717-15	-				
0.7040	FCD400	GGG40	60-40-18	SNG 420-12	GJS-400-15	FCS 400-12	0717-02	GS 400-12	FG E38-17	F32800	Vc 42-12	
0.7043	FCD 370	GGG40.3	60-40-18	SNG 370-17	GJS-400-18-LT	FGS 370-17	0717-12	GSO 42-17			Vc 42-12	
0.6040	FC400	GG40	A48 60 B	Grade 400	GJL-400	Ft 40 D	0140	G40	FC40		Sc 40	

Mat'l No.	JIS	DIN	Material Description			Composition / Structure / Heat Treatment					HB	HRc
			AISI/ASTM/SAE	BS	EN	AFNOR	SS	UNI	UNE / IHA	UNS		
K VDI 3323 18 Nodular cast iron Pearlitic HB 250 HRc 25												
0.7050	FCD500	GGG50	80-55-06	SNG 500-7	GJS-500-7	FGS 500-7	0727-02	GS 500-7	FG E50-7	F33100	Vc 50-2	
0.7060	FCD600	GGG60	80-55-06	SNG 600-3	GJS-600-3	FGS 600-3	0732-03	GS 600-3	FG E60-2		Vc 60-2	
0.7070	FCD700	GGG70	100-70-03	SNG 700-2	GJS-700-2	FGS 700-2	0737-01	GS 700-2	FG S70-2	F34800	Vc 70-2	
0.7652	FCDANiMn 13.7	GGG NiMn 13.7	-	Grade 56	GJSA-XNiMn 13-7	FGS Ni13 Mn7	0772	-			Nodumag	
0.7660		GGG NiCr 20.2	A436 D2	Grade 52	GJSA-XNiCr 20-2	FGS Ni20 Cr2	0776	-			Ni-Resist D-2	

Technical Information Material Groups

Mat'l No.	JIS	DIN	Material Description			Composition / Structure / Heat Treatment					HB	HRc
			AISI/ASTM/SAE	BS	EN	AFNOR	SS	UNI	UNE / IHA	UNS		
K VDI 3323 19 Malleable cast iron Ferritic HB 130												
0.8135	FCMW330	GTS-35	32510	B 340-12	GJMB350-10	MN 35-10	0815	GMN 35	GTS35		Kc 35-10	

Mat'l No.	JIS	DIN	Material Description			Composition / Structure / Heat Treatment					HB	HRc
			AISI/ASTM/SAE	BS	EN	AFNOR	SS	UNI	UNE / IHA	UNS		
K VDI 3323 20 Malleable cast iron Pearlitic HB 230 HRc 21												
0.8145	FCMW370	GTS-45	A220-40010	P 440-7	GJMB450-6	MN 450	0852	GMN 45				
0.8155	FCMP490	GTS-55	50005	P 510-4	GJMB-550-4	MP 50-5	0854	GMN 55			Kc 60-3	
0.8165	FCMP590	GTS-65	70003	P 570-3	GJMB-650-2	MN 650-3	0856	GMN 65				
0.8170	FCMP690	GTS-70	90001	P 690-2	GJMB-700-2	MN 700-2	0862	GMN 70			Kc 70-2	

Technical Information Material Groups

Mat'l No.	JIS	DIN	AISI/ASTM/SAE	BS	EN	AFNOR	SS	UNI	UNE / IHA	UNS	GOST	Brands	N	VDI 3323 21	Material Description Aluminum-wrought alloy	Composition / Structure / Heat Treatment Not Curable	HB 60	HRc
3.0205		Al99	Al99															
3.0255	(A1050)	Al99.5	1000	L31		A59050C						D1						
3.3315		AlMg1																

Mat'l No.	JIS	DIN	AISI/ASTM/SAE	BS	EN	AFNOR	SS	UNI	UNE / IHA	UNS	GOST	Brands	N	VDI 3323 22	Material Description Aluminum-wrought alloy	Composition / Structure / Heat Treatment Curable, Hardened	HB 100	HRc
3.1325		AlCuMg1										AD35						
3.1655	A2011	AlCuSiPb																
3.2315		AlMgSi1										AK9						
3.4345		AlZnMgCuO.5	7050	L86		AZ4GU/9051				811-04								
3.4365	7075	AlZnMgCu1.5	7075	7075		7075		AlZn5.8MgCuCr				B95						

Mat'l No.	JIS	DIN	AISI/ASTM/SAE	BS	EN	AFNOR	SS	UNI	UNE / IHA	UNS	GOST	Brands	N	VDI 3323 23	Material Description Aluminum-cast, alloyed	Composition / Structure / Heat Treatment ≤ 12% Si, Not Curable	HB 75	HRc
3.2163		G-AlSi9Cu3										VAL8						
3.2382		GD-AlSi10Mg																
3.2383		G-AlSi0Mg(Cu)	A360.2	LM9				4253										
3.2581		G-AlSi12																
3.3561		G-AlMg5																
3.5101		G-MgZn4sE1Zr1	ZE41	MAG5														
3.5103		MgSE3Zn27r1	EZ33	MAG6		G-TR3Z2												
3.5812		G-MgAl8Zn1	AZ81	NMAG1														
3.5912		G-MgAl9Zn1	AZ91	MAG7														
			A356-72	2789		NFA32-201												
A5052			356.1	LM25				4244				AK7						
		G-AlSi12	A413.2	LM6				4261										
ADC12		G-AlSi12(Cu)	A413.1	LM20				4260				AK12						
A6061		GD-AlSi12	A413.0					4247										
A7075		GD-AlSi8Cu3	A380.1	LM24				4250										

Technical Information Material Groups

Mat'l No.	JIS	DIN	AISI/ASTM/SAE	BS	EN	AFNOR	SS	UNI	UNE / IHA	UNS	GOST	Brands	N	VDI 3323 24	Material Description Aluminum-cast, alloyed	Composition / Structure / Heat Treatment ≤ 12% Si, Curable, Hardened	HB 90	HRc
2.1871		G-AlCu4TiMg																
3.1754		G-AlCu5Ni1.5																
3.2371		G-AlSi7Mg	4218B									AK8						
3.2373	C485	G-AlSi9MgWA	SC64D			A-S7G	4251					AK9						
3.2381		G-AlSi10Mg										AK12						
3.5106		G-MgAg3SEZr1	QE22	mag12														
		G-ALMG5	GD-AISI12	LM5		A-SU12	4252											

Mat'l No.	JIS	DIN	AISI/ASTM/SAE	BS	EN	AFNOR	SS	UNI	UNE / IHA	UNS	GOST	Brands	N	VDI 3323 26	Material Description Copper and Copper Alloys (Bronze / Brass)	Composition / Structure / Heat Treatment Cutting alloys, PB>1%	HB 110	HRc
2.0375		CuZn36Pb3										LS60-2						
2.1090		G-CuSn75pb	C93200			U-E7Z5pb4												
2.1096		G-CuSn5ZnPB	c83600	LG2														
2.1098		G-CuSn2Znpb	C83600															
2.1182		G-CuPb15Sn	C23000	LB1		U-pb15E8												

Mat'l No.	JIS	DIN	AISI/ASTM/SAE	BS	EN	AFNOR	SS	UNI	UNE / IHA	UNS	GOST	Brands	N	VDI 3323 27	Material Description Copper and copper alloys (Bronze / Brass)	Composition / Structure / Heat Treatment CuZn, CuSnZn (Brass)	HB 90	HRc
2.0240	C2300	CuZn15										L90						
2.0321		CuZn37	C27200	cz108		CuZn36,CuZn37		C2700				L63						
2.0590		G-CuZn40Fe																
2.0592		G-CuZn35Al1	C86500	U-Z36N3		HTB1												
2.0596		G-CuZn34Al2	C86200	HTB1		U-Z36N3						LTs23AD						
2.1293		CuCrZr	C18200	CC102		U-Cr0-8Zr												

Mat'l No.	JIS	DIN	AISI/ASTM/SAE	BS	EN	AFNOR	SS	UNI	UNE / IHA	UNS	GOST	Brands	N	VDI 3323 28	Material Description Copper and copper alloys (Bronze / Brass)	Composition / Structure / Heat Treatment CuSn, lead-free copper and electrolytic copper	HB 100	HRc
2.0060		E-Cu57																
2.0966		CuAl10Ni5Fe4	C63000	Ca104		U-A10N						BrAD						
2.0975		G-CuAl10Ni	B-148-52															
2.1050		G-CuSn10	c90700	CT1														
2.1052		G-CuSn12	C90800	pb2		UE12P												
2.1292		G-CuCrF35	C81500	CC1-FF														

Technical Information Material Groups

Mat'l No.	JIS	DIN	Material Description			Composition / Structure / Heat Treatment					HB	HRc
			AISI/ASTM/SAE	BS	EN	AFNOR	SS	UNI	UNE / IHA	UNS		
S VDI 3323 31 Heat resistant super alloys Fe Based, Annealed HB 200 HRc 15												
1.4558	NCF 800 TB	X2NiCrAlTi3220	N08800	NA15								
1.4562		X1NiCrMoCu32287	N08031									
1.4563		X1NiCrMoCu31274	N08028		Z1NCDU31-27-03	2584					EK77	
1.4864	SUH330	X12NiCrSi36-16	330	NA17	Z12NCS37-18						N08330	
1.4865	SCH15	GX40NiCrSi38-18		330C40			XG50NiCr3919				J94605	
1.4958		XSNiCrAlTi3120										

Mat'l No.	JIS	DIN	Material Description			Composition / Structure / Heat Treatment					HB	HRc
			AISI/ASTM/SAE	BS	EN	AFNOR	SS	UNI	UNE / IHA	UNS		
S VDI 3323 32 Heat resistant super alloys Fe Based, Aged HB 280 HRc 30												
1.4977		X40CoCrNi2020				Z42CNKDOWNb						

Mat'l No.	JIS	DIN	Material Description			Composition / Structure / Heat Treatment					HB	HRc
			AISI/ASTM/SAE	BS	EN	AFNOR	SS	UNI	UNE / IHA	UNS		
S VDI 3323 33 Heat resistant super alloys Ni or Co Based, Annealed HB 250 HRc 25												
2.4360		NiCu30Fe		NA13		NU30					N04400	Monel400
2.4603		NiCr30FeMo	5390A			NC22FeD						Hastelloy G-30
2.4610		NiMo16Cr16Ti									N26455	Hastelloy C-4
2.4630		NiCr20Ti		HRS,203-4		NC20T					N06075	Nimonic75
2.4631	NCF 80A	NiCr20TiAl		Hr40		NC20TA					N07080	KHN77TYuR Nimonic 80A
2.4642	NCF 690	NiCr29Fe				Nnc30Fe					N06690	Inconel 690
2.4856		NiCr22Mo9Nb		NA21		NC22FeDnb					N06625	Inconel 625
2.4858		NiCr21Mo		NA16		NC21FeDU					N08825	KHN38VT Incoloy 825

Mat'l No.	JIS	DIN	Material Description			Composition / Structure / Heat Treatment					HB	HRc
			AISI/ASTM/SAE	BS	EN	AFNOR	SS	UNI	UNE / IHA	UNS		
S VDI 3323 34 Heat resistant super alloys Ni or Co Based, Aged HB 350 HRc 38												
2.4375		NiCu30Al	4676	NA18		NU30AT					N05500	MonelK500
2.4662		NiFe35Cr14MoTi	5660			Z5NCDT42					N09901	Incoloy 901
2.4668		NiCr19Fe19NbMo	5383	HR8		NC19eNB					N07718	Inconel 718
2.4670		S-NiCr13Al16MoNb	5391	Mar-46		NC12AD						Nimocast 713
2.4694		NiCr16Fe7TiAl									N07751	Inconel 751
2.4955		NiFe25Cr20NbTi										
2.4964		CoCr20W15Ni	5772			KC20WN						Haynes 25
		CoCr22W14Ni	AMS 5772			KC22WN						

Technical Information Material Groups

Mat'l No.	JIS	DIN	Material Description			Composition / Structure / Heat Treatment					HB	HRc
			AISI/ASTM/SAE	BS	EN	AFNOR	SS	UNI	UNE / IHA	UNS		
S VDI 3323 35 Heat resistant super alloys Ni or Co Based, Cast HB 320 HRc 34												
2.4669		NiCr15Fe7TiAl									NC15TNbA	N07750 Inconel X750
2.4685		G-NiMo28										N10665 Hastelloy B
2.4810		G-NiMo30										Hastelloy C
2.4973		NiCr19Co11MoTi	AMS 5399								NC19KDT	VT5-1
3.7115		TiAl5Sn2										VT1-00 ATI Grade 6

Mat'l No.	JIS	DIN	Material Description			Composition / Structure / Heat Treatment					HB	HRc
			AISI/ASTM/SAE	BS	EN	AFNOR	SS	UNI	UNE / IHA	UNS		
S VDI 3323 36 Titanium alloys Pure Titanium HB 400 Rm												
2.4674		NiCo15Cr10MoAlTi	AMS 5397									N13100 IN 100
3.7025		Ti1	R50250	2TA1								R50250 ATI30 CP Gr.1
3.7225		Ti1pd	R52250	TP1								R52250

Mat'l No.	JIS	DIN	Material Description			Composition / Structure / Heat Treatment					HB	HRc
			AISI/ASTM/SAE	BS	EN	AFNOR	SS	UNI	UNE / IHA	UNS		
S VDI 3323 37 Titanium alloys Alpha + Beta Alloys, Hardened HB 1050 Rm												
3.7124		TiCu2				2TA21-24						
3.7145		TiAl6Sn2Zr4Mo2Si	R54620									R54620
3.7165		TiAl6V4	AMS R56400	TA10-13			T-A6V					VT6
3.7185		TiAl4Mo4Sn2		TA45-51								
3.7195		TiAl3V2.5										R56320 ATI 3-2.5
		TiAl4Mo4Sn4Si0.5										
		TiAl5Sn2.5	AMS R54520	TA14/17			T-A5E					
		Ti6Al4VELI	AMS R56401	TA11								

Technical Information
Material Groups

Mat'l No.	JIS	DIN	Material Description			Composition / Structure / Heat Treatment					HB	HRc
			AISI/ASTM/SAE	BS	EN	AFNOR	SS	UNI	UNE / IHA	UNS		
<p>H VDI 3323 38 Material Description: Hardened steel Composition / Structure / Heat Treatment: Hardened HB: 550 HRc: 55</p>												
1.1231	S70 C-CSP	Ck 67	1070	060 A 67	C 67 S	XC 68	1770	C 70	F 5103		70	
1.1248	C 75	Ck 75	1078, 1080	060 A 78	C 75 S	XC 75	1774	C 75	F 5107		75	
1.1274	SUP 4	Ck 101	1095	060 A 96	C 100 S	XC 100	1870	C 100	F 5117			
1.1545	SK 3	C 105 W1	W1	BW 2	C 105 U	Y1 105	1880	C 100 KU	F 5118		U10A	
1.2762		75CrMoNiW67	-	-	-	-	-	-	-			
1.3401	SCMnH1	GX120Mn12	A128(A)			Z120M12	2183	GX120Mn12	F8251		110G13L	
1.4021	SUS 420 J1	X 20 Cr 13	420	420 S 37	X 20 Cr 13	Z 20 C 13	2303	X 20 Cr 13	F 5261		20KH13	ATI 420
1.4109	SUS 440 A	X 65 CrMo 14	440 A	-	X 70 CrMo 15	Z 70 D 14	-	-	-			ATI 440A
1.4112	SUS 440 B	X 90 CrMoV 18	440 B	409 S 19	X 90 CrMoV 18	Z 2 CND 18 05	2327	X CrTi 12				
1.4125	SUS 440 C	X 105 CrMo 17	440 C	-	X 105 CrMo 17	Z 100 CD 17	-	X 105 CrMo 17			95KH18	ATI 440C
1.6746		32NiCrMo14-5	-	832M31	32nicRmO145	35NCD14	-	-				
1.7176	SUP9(A)	55Cr3	5155	527A60	48	55C3	2253	55Cr3				
1.7225	SCM 440 (H)	42CrMo4	4140	708 M 40	42 CrMo 4	42 CD 4	2244	42 CrMo 4	F.1252			38HM

Mat'l No.	JIS	DIN	Material Description			Composition / Structure / Heat Treatment					HB	HRc
			AISI/ASTM/SAE	BS	EN	AFNOR	SS	UNI	UNE / IHA	UNS		
<p>H VDI 3323 40 Material Description: Chilled cast iron Composition / Structure / Heat Treatment: Cast HB: 400 HRc: 42</p>												
0.9620		GX260NiC42	A532 IB	Grade 2 A	GJN-HV520	FB N14 Cr2 BC	0512	-		F45001		Ni-Hard2
0.9625		GX330NiC42	A532 IA	Grade 2 B	GJN-HV550	FB N14 Cr2 HC	0513	-		F45000		Ni-Hard1
0.9630		GX300CrNiSi9 5 2	A532 ID	Grade 2 C	GJN-HV600	FB G9 Ni5	0457	-		F45003		Ni-Hard 4
0.9640		GX300CrMoNi1521	-	-	-	-	-	-		F45005		
0.9650		GX260Cr27	-	Grade 3 D	-	-	0466	-				
0.9655		GX300CrNiMo271	-	Grade 3 E	-	-	-	-		20C 25N20S2		
1.4841	SUH 310	X15CrNiSi25-20	310	314531	X 15 CrNiSi 25 20	Z15CNS25-20	-	-		S31400		Cronifer 2520

Mat'l No.	JIS	DIN	Material Description			Composition / Structure / Heat Treatment					HB	HRc
			AISI/ASTM/SAE	BS	EN	AFNOR	SS	UNI	UNE / IHA	UNS		
<p>H VDI 3323 41 Material Description: Hardened cast iron Composition / Structure / Heat Treatment: Hardened HB: 550 HRc: 55</p>												
0.9635		GX300 CrMo 15 3	-	-	-	-	-	-				
0.9645		GX260 CrMoNi 20 21	-	-	-	-	-	-		F45007		

Application Guide
Steel Guide

Grade Recommendation based on Workpiece Material Condition

<p>Pre Machined Condition No Outer Skin Uniform hardness on material Has stable machining condition</p>	<p>HARD</p> <p>↑</p> <p>YG3115</p> <p>YG3020</p> <p>YG3030</p> <p>↓</p> <p>TOUGH</p>
<p>Welded Condition Soft / No Outer Skin Weld Bead Could be of Different Hardness than Actual Part Stock on Part could even except weld Seam during Machining causing shock loads</p>	
<p>Cast Condition Hard Outer Skin Could have Sand Inclusion,- if Green Sand Cast Component could have uneven Stock during machining</p>	
<p>Hot Rolled Condition Soft / No Outer Skin Usually heat treated before machine to reduce Hardness Component could have uneven Stock During Machining</p>	
<p>Forged Condition Soft Outer Skin Usually heat treated before machine to reduce Hardness Component could have uneven Stock during machining</p>	

Chipbreaker, Feed Rate and Depth of Cut

	Sharp Edge	General	Strong Edge
Continuous			
General			
Heavy Interrupt			

Application Guide
Steel Guide

P Non Alloy Steel, About 0.15% C (Low Carbon Steel)										
VDI	JIS	DIN	Mat'l No.	AISI/ASTM	SS	AFNOR	UNI	UNE	BS	GOST
1	S15C	CK15	1.0401	1015	1350	XC18	C15	F.1110	080M15	15

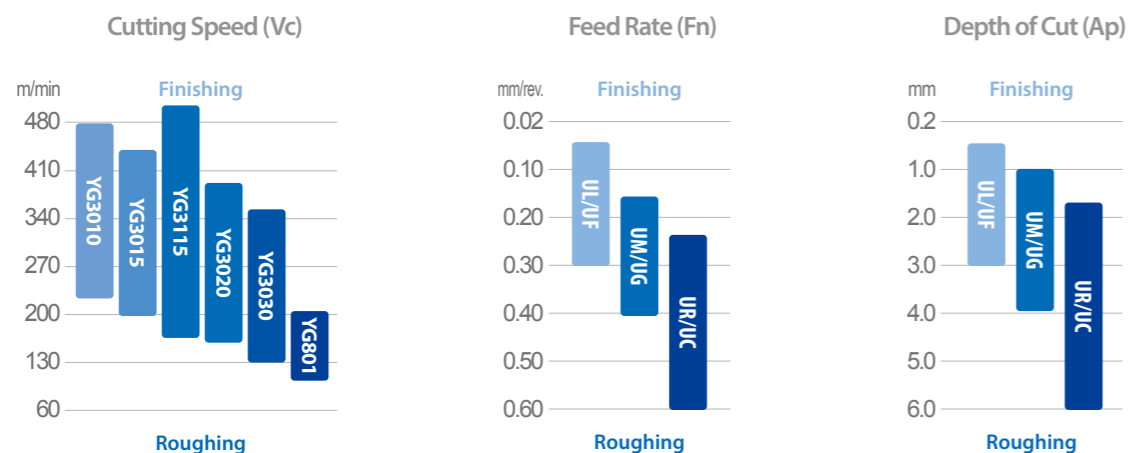

First Choice Grade and Value
YG3030 - Vc 280m/min

P Non Alloy Steel, About 0.45% C (Medium Carbon Steel)										
VDI	JIS	DIN	Mat'l No.	AISI/ASTM	SS	AFNOR	UNI	UNE	BS	GOST
2-3	S45C	C45	1.0503	1045	1672	XC42H1TS	C45	F.1140	060A47	45

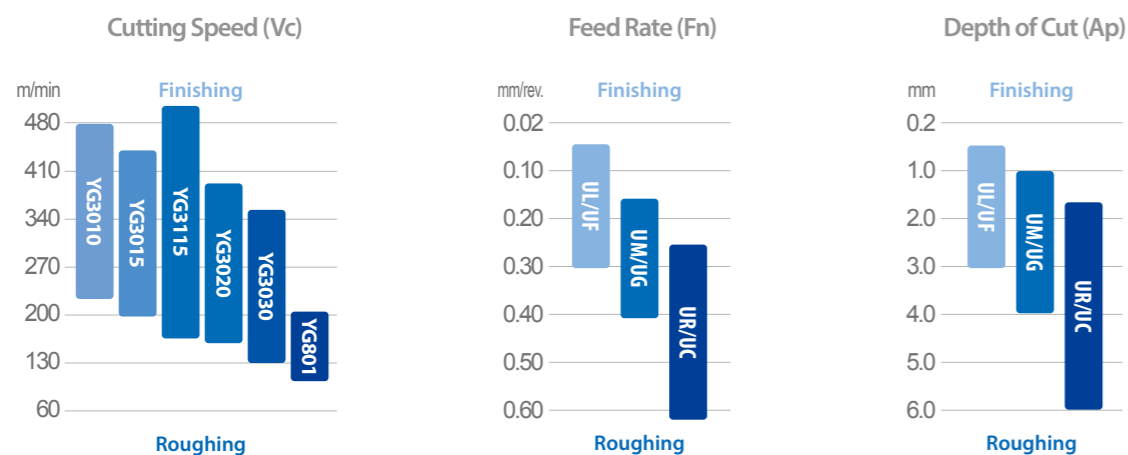

First Choice Grade and Value
YG3115 - Vc 330m/min

Application Guide
Steel Guide

P Low-alloyed Steel										
VDI	JIS	DIN	Mat'l No.	AISI/ASTM	SS	AFNOR	UNI	UNE	BS	GOST
6-9	SCM440	42CrMo4	1.7225	4140	2244	42 CD 4	42CrMo4	F.1252	708M40	38HM

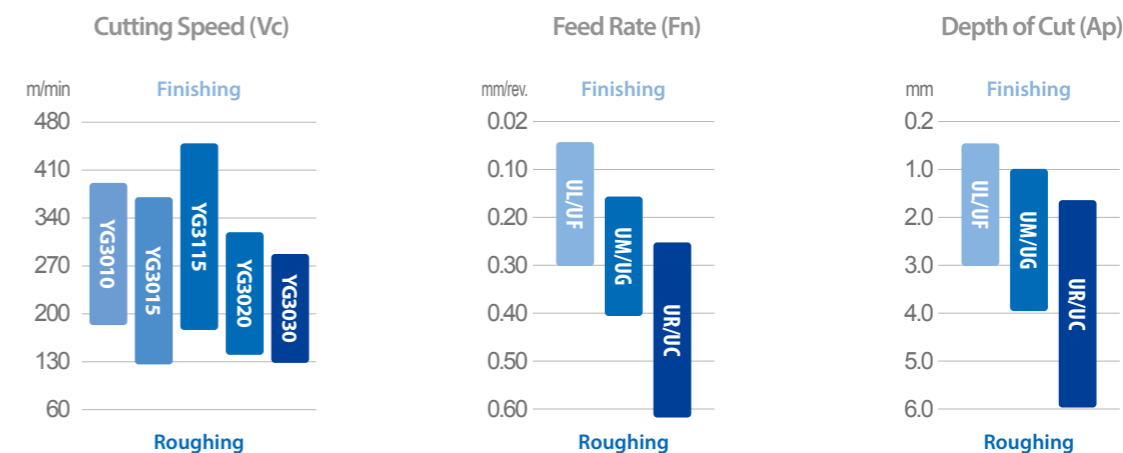

First Choice Grade and Value
YG3020 - Vc 240m/min

P High Alloyed Steel, and Tool Steel										
VDI	JIS	DIN	Mat'l No.	AISI/ASTM	SS	AFNOR	UNI	UNE	BS	GOST
10-11	SKD11	X155CrVMo121	1.2379	D2	2310	Z160CDV12	X165CrMoW12KU	F.5318	BD2	KH12MF

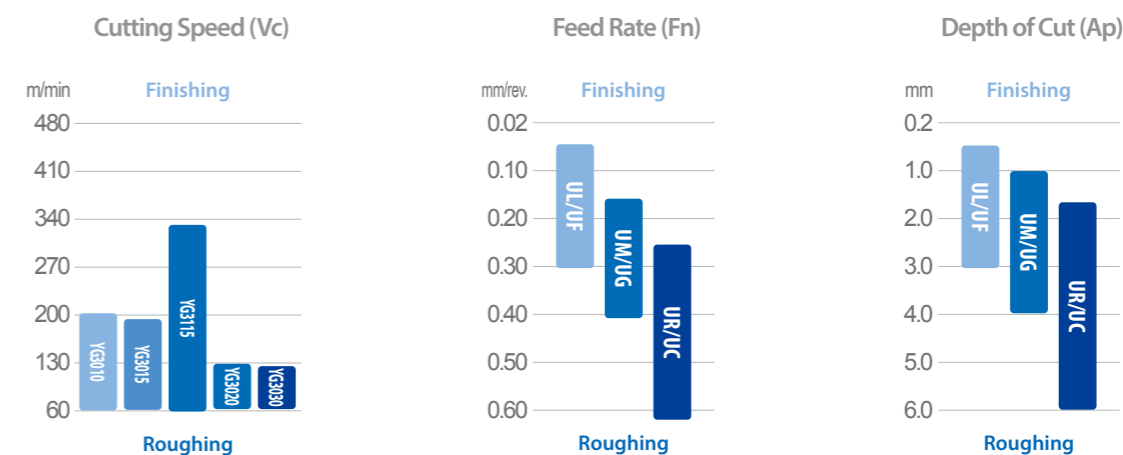

First Choice Grade and Value
YG3115 - Vc 150m/min

Application Guide
Stainless steel Guide

M	Ferritic / Martensitic Stainless									
VDI	JIS	DIN	Mat'l No.	AISI/ASTM	SS	AFNOR	UNI	UNE	BS	GOST
12~13	SUS430	X6Cr17	1.4016	430	2320	Z8C17	Z8C17	F3113	430S15	12C17

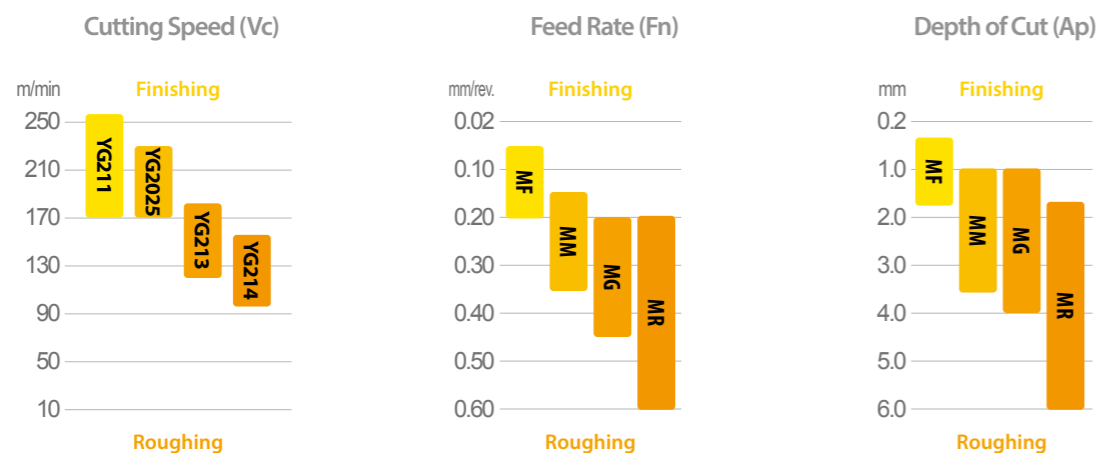

First Choice Grade and Value

Ferritic Stainless steel
YG213 - Vc 160m/min
YG2025 - Vc 190m/min

Martensitic
YG213 - Vc 130m/min
YG2025 - Vc 160m/min

M	Austenitic Stainless steel									
VDI	JIS	DIN	Mat'l No.	AISI/ASTM	SS	AFNOR	UNI	UNE	BS	GOST
14	SUS304	X5CrNi18 9	1.4350	304	2332	Z6CN18 09	X5CrNi18 10	F3551	304S15	03KH18N11

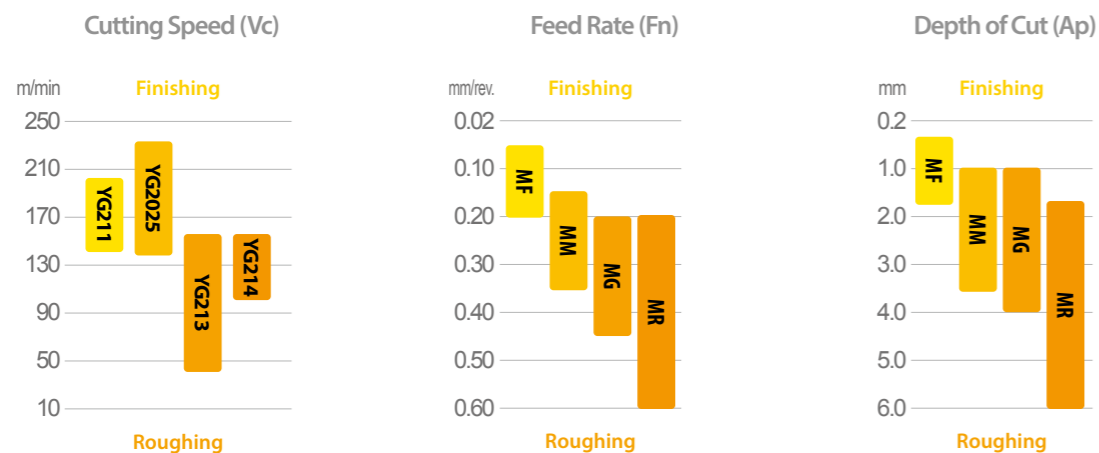

First Choice Grade and Value

YG2025 - Vc 190m/min

Application Guide
Cast iron Guide

K	Grey cast iron									
VDI	JIS	DIN	Mat'l No.	AISI/ASTM	SS	AFNOR	UNI	UNE	BS	GOST
15~16	FC250	GG25	0.6025	A48 40 B	0125	Ft 25 D	G25	FG25	Grade 260	Sc 25

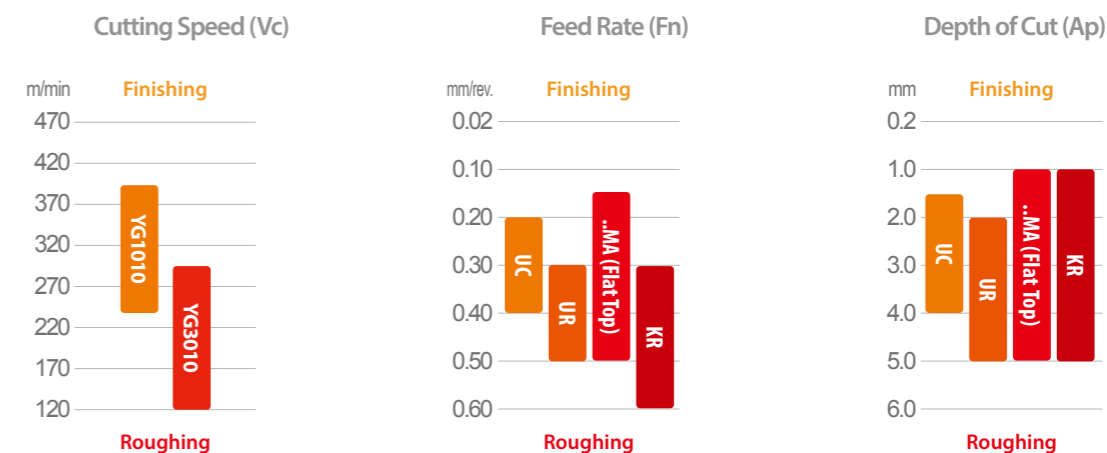

First Choice Grade and Value

YG1010 - Vc 320m/min

K	Nodular cast iron									
VDI	JIS	DIN	Mat'l No.	AISI/ASTM	SS	AFNOR	UNI	UNE	BS	GOST
17~18	FCD500	GGG50	0.7050	80-55-06	0.7050	FGS 500-7	GS 500-7	FGE50-7	SNG 500-7	Vc 50-2

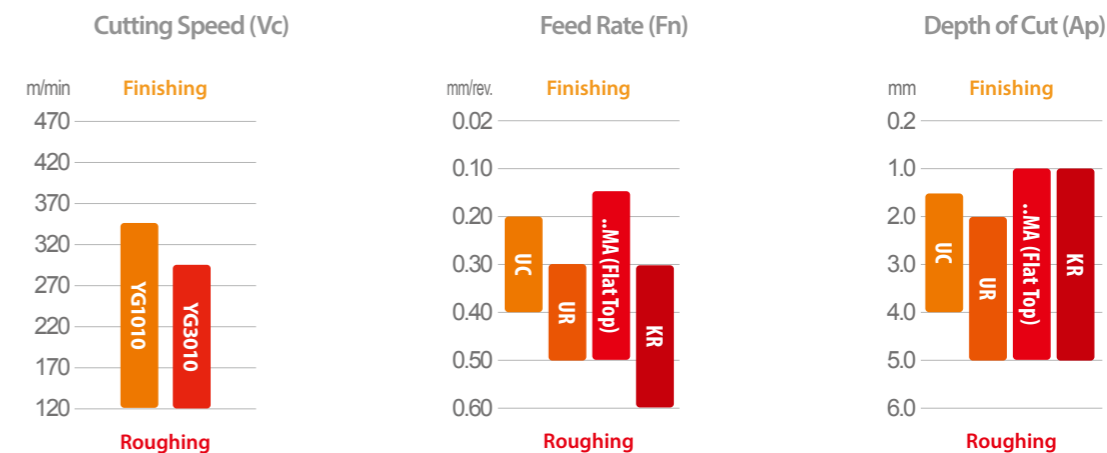

First Choice Grade and Value

YG1010 - Vc 230m/min

Application Guide
HRSA Guide

S Superalloys & Titanium Alloys										
VDI	DIN	Mat'l No.	AISI/ASTM	AFNOR	BS	UNS	Brands	UNE	BS	GOST
31-37	NiCr19Fe19NbMo	2.4668	5383	NC19eNB	HR8	N07718	Inconel 718	F3113	430S15	12C17

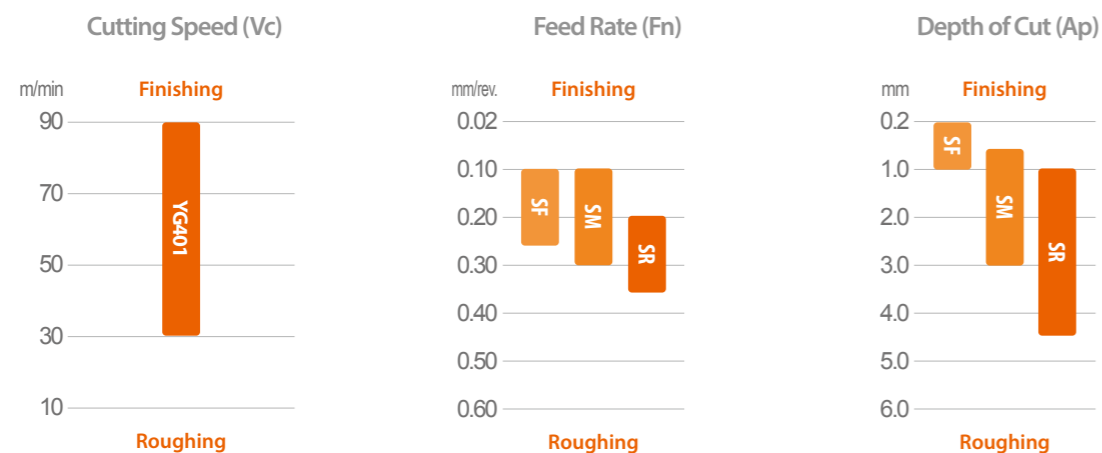

First Choice Grade and Value
YG401 - Vc 50m/min

Application Guide
Surface Roughness Guide

Trouble Shooting

Pattern	Reasons	Solutions
<p>Vibration</p> <ul style="list-style-type: none"> - High radial or tangential force - Unstable condition 	<ul style="list-style-type: none"> - Lower depth of cut (ap) - Use sharper chipbreaker 	
<p>Bad Surface</p> <ul style="list-style-type: none"> - Work material is damaged by chips - Feed is too high for corner radius 	<ul style="list-style-type: none"> - Different chipbreaker - Lower depth of cut (ap) - Lower feed - Larger corner radius 	

Theoretical Surface Roughness

Ra / Rz μ m	Insert Corner Radius Code ISO					
	02	04	08	12	16	24
0.4 / 1.6	0.05	0.07	0.1	0.12	0.14	0.18
1.6 / 6.3	0.1	0.14	0.2	0.25	0.28	0.35
3.2 / 12.5	0.14	0.2	0.28	0.35	0.4	0.49
6.3 / 25	-	0.28	0.4	0.49	0.57	0.69
8 / 32	-	-	0.45	0.55	0.64	0.78

Application Guide
Trouble Shooting

Trouble Shooting Guide map

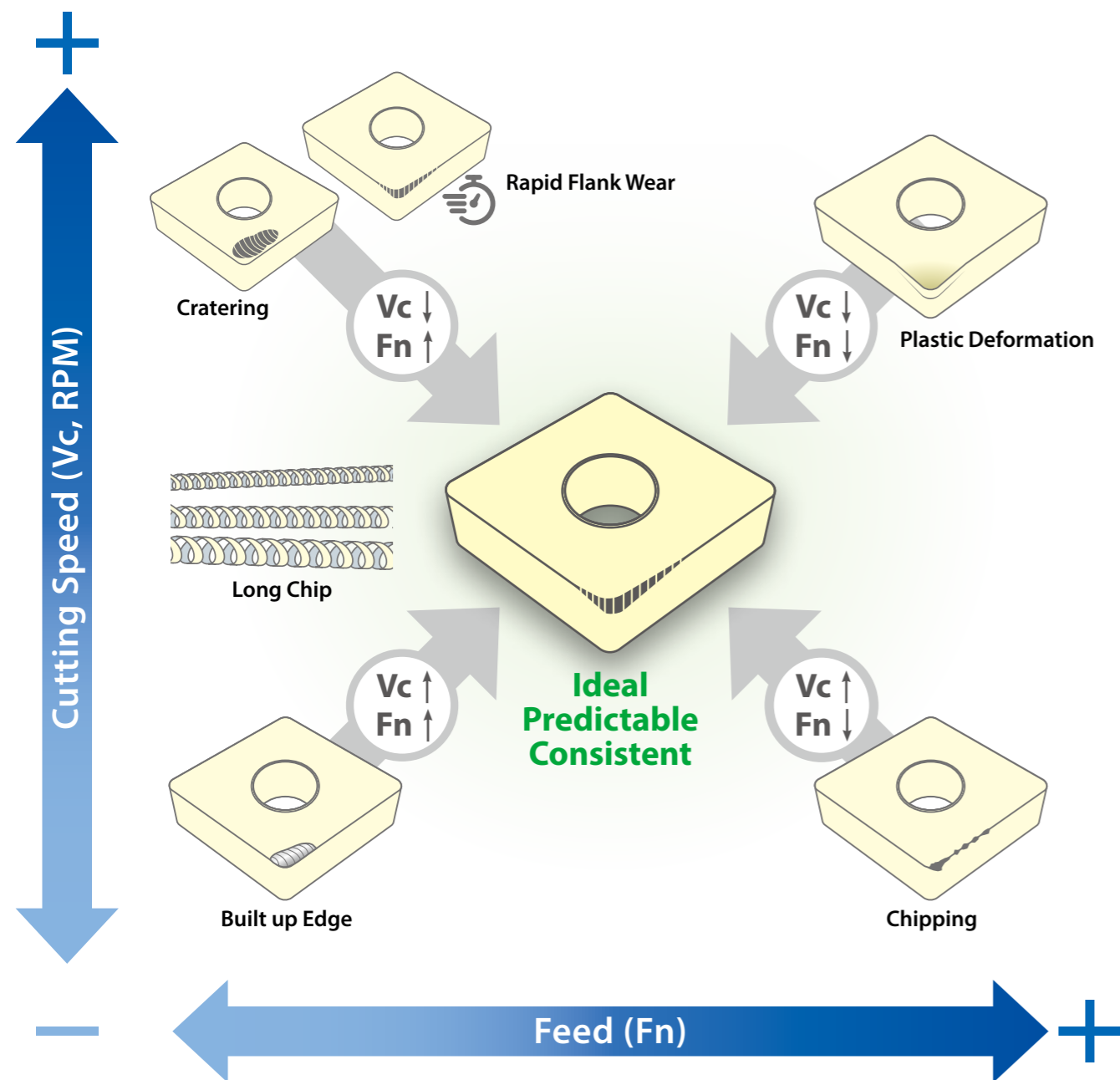

Application Guide
Trouble Shooting

Pattern	Reasons	Solutions
<p>General Flank Wear</p> <p>Flank face near by corner is abraded</p>	<ul style="list-style-type: none"> - The most ideal wear - Consistent and predictable - General wear behavior when machining condition is normal 	
<p>Rapid Flank Wear</p> <p>Looks same as general flank wear, but happens quickly</p>	<p>Grade</p> <ul style="list-style-type: none"> - Not enough wear resistance - Too tough grade <p>Heat</p> <ul style="list-style-type: none"> - Cutting speed is too high - Not enough coolant 	<ul style="list-style-type: none"> - More wear resistant grade - Reduce the cutting speed (Vc, SFM, RPM or SFPM) - Optimize coolant - Increase Feed (Fn) if feed is low
<p>Plastic Deformation</p> <p>Deformed Edge</p>	<ul style="list-style-type: none"> - Excess thermal load - Excess mechanical load 	<ul style="list-style-type: none"> - Reduce cutting temperature - More wear resistant grade - Reduce the cutting speed (Vc, SFM, RPM or SFPM) - Lower feed (Fn) - Lower depth of cut (ap) - Optimize coolant
<p>Built up Edge</p> <p>Workpiece material is welded on the cutting edge</p>	<ul style="list-style-type: none"> - Sticky materials (low carbon steel, Stainless steel, non-ferrous metal, heat resistant super alloys) - Too low cutting speed 	<ul style="list-style-type: none"> - Increase cutting speed - Lower feed rate - Sharper chipbreaker & geometry - Use high pressure coolant - Use PVD grade - Use Positive Insert
<p>Cratering</p>	<p>Heat</p> <ul style="list-style-type: none"> - Cutting speed is too high - Too tough grade 	<ul style="list-style-type: none"> - Reduce cutting temperature - Lower cutting speed (Vc, SFM, RPM or SFPM) - Adjust Feed (Fn) - Harder grade

Application Guide
Trouble Shooting

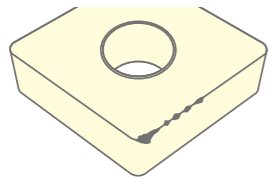
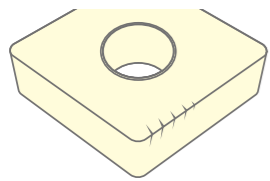
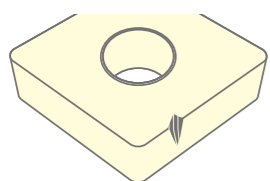
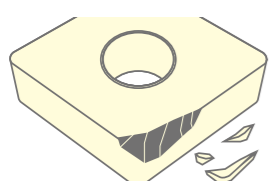
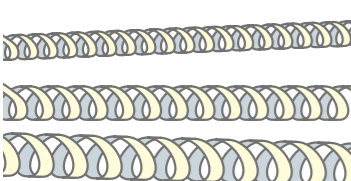
Pattern	Reasons	Solutions
<p>Chipping</p> 	<ul style="list-style-type: none"> - Unstable machining condition (Vibration) - Grade is too hard / brittle - Cutting edge is too sharp 	<ul style="list-style-type: none"> - Focus on stabilizing cutting condition - Reduce overhang (shorter and bigger tool) - Tougher grade - Tougher chipbreaker
<p>Thermal Crack</p> 	<ul style="list-style-type: none"> - Thermal stress due to rapid change of temperature 	<ul style="list-style-type: none"> - Tougher grade - Lower cutting speed (Vc, SFM, RPM or SFPM) - Lower feed (Fn) - Sharper chipbreaker - Change coolant / dry cut
<p>Notching</p> 	<ul style="list-style-type: none"> - Improved edge strength work piece has hardened skin 	<ul style="list-style-type: none"> - More wear resistant grade - Reduce the cutting speed (Vc, SFM, RPM or SFPM) - Adjust Feed (Fn) - Lower depth of cut (ap) - Optimize coolant - Go for tougher chipbreaker
<p>Breakage (Mechanical Fracture)</p> 	<ul style="list-style-type: none"> - Mechanical load is too heavy (feed or depth is too high) - Heavy interrupted cut - Grade is too hard for work material - Unstable machining (vibration) - Cutting speed is too low - Impurities in work material 	<ul style="list-style-type: none"> - Lower feed (Fn) or depth of cut (ap) - Tougher grade - Reduce overhang and check stability of tool and work material - Higher cutting speed (Vc, SFM, RPM or SFPM)
<p>Long Chip</p> 	<ul style="list-style-type: none"> - Feed is too low for chip breaking - Depth of cut is too shallow for corner radius - Chip area (Fn x Ap) too low 	<ul style="list-style-type: none"> - Higher feed - Sharper chipbreaker - Higher depth of cut - Select a smaller corner radius

Technical Information
Comparison Chart - Turning Chipbreakers

Negative Inserts

ISO	Application	YG-1	SANDVIK	ISCAR	KENNAMETAL	Seco	Walter	Mitsubishi	Kyocera	Tungaloy	Sumitomo	Taegutec	Korloy
P	Super Finish	SF	-	SF	FF (G-class), WF, UF	FF1, FF2	FP5, FV5	PK (G-class), FY, FH, FS	DP (G-class), GP WQ	01, TF	FA, FL, FB	FA	VL
	Finish	UF	QF	F3P, NF	FN	MF2	NF4, NF3	FP, C	PP, GP DP, XF, XP	TS, TSF, ZF, 11, NS, NM, CB	LU, FE, SU	FLP, FA, FS, GG-FU, FX, FLP, FG, FM	VF, VB
	Semi Finish	PSF	XF	NF, TF	FN	MF2	MP3	FP, FH	HQ	TSF	NSU	FG, FM	VQ
		UL	PF, XF		FN, MN	MF3	NS6	C (Cermet)	CQ, VC, PP	AS	SE	MLP, FC, FT	VQ, VC
		UM			-	MF5	MP3	SH, SA, LP	PQ, CJ, VF, XQ	ZM, AM	SX		LP
	Medium	UG	PM, QM, XM	PP, TF, M3P, M4PW	MN	M3, M5, MR3	NM4, MP5, MU5, NM6	MA, MH, MP MV	GS, PS, PG	TM AM, DM, ZM	GU (□UG□), GE, UX	MLP, MC, MGP, PC, MM	VM, MP
	Rough	UC	PR	GN	MR, RP	MR4, M5, M6	MG-	MG- None C/B	XS	TH, THS	UZ	MT, MGP, MG-	B25
		UR	XMR	R3P, NR	RN	MR3, MR6	NR4, RP5, RP7	RP, GH	PT, GT, PH	TU, TRS, TUS	MU, ME, MX	RGP, RT, RX	HR, GR
	Wiper	PWM	WF, WR, WMX, VM	WF, WG	FW, MW, RW	W-M3, W-MF2, W-MF5, M6, W-R4	NF, NM	SW, MW	WP, WF, WQ, WE	AFW, FW, ASW, SW	LUW, SEW, GUW	WS, WA, WT	VW, LW
	M	Finish	MF	SF, F3M, NF	FF, FP	MF1	NF4, FM5	SH, LM	MQ, SQ	SF, SA	SU, EF	EA, SF	VP2, MP
Medium		MM	MM	M3MW, TF, M3M	MP, UP	MF4	MM5(NM4)	MS, GM	TK, MS	SM, SS	GU	EM, ML	HS, MM
		MG		VL, PP	MR		RM5, NR4	MM, ES	SG, SX	S, TA	EX, EG		
Rough	MR	MR, XMR, MRR	GN, R3M, NR	P, RP	M5, M6 MR7, RR6	NRS	GH, RM	MU	TH, SH, TU	MU, HM, EM	ET	GS, RM	
K	Finish	UC	KF, M3P, GN	T-20, FN, MT	MF3, MF5, M4	NM, MK5	LK, MA	None C/B, C	CF	UZ	MT	MP	
	Medium	UG	KM, GN, A	UN(RP), T-20	M5	NM5, RK5	MK, GK	KQ, KG	CM, None C/B	GZ	MG-	B25, MK	
	Rough	..MA	KR, KRR	NR, A	MR, S-20, ... MA, T-20	MR7	MV7, RK7	RK, -MA	-MA, GC, KH, ZS	CH	(□UX□)	KT, RT	-MA, RK
S	Super Finish	SF	SF	SF	FS (G-class) LF (G-class)	MF1	NF4	FJ(G-class)	MQ	-	EF	EA, SF	VP1
	Medium	SM	NGP, SM	PP, TF, VL	MS, GP, P, UN	MF4	NMS, NMT	MJ(G-class), MS	SQ, MS, MU, TK	HRM HMM	EX	EM MGS, MP, MK	VP3
	Rough	SR	SR, SMR	MR	RP	MR3, MR4	NRS, NRT	RS, GJ	SG, SX	SA	MU	ET	VP4

Positive Inserts

ISO	Application	YG-1	SANDVIK	ISCAR	KENNAMETAL	Seco	Walter	Mitsubishi	Kyocera	Tungaloy	Sumitomo	Taegutec	Korloy
P	Finish	PF	PF	PF, F3P	FP	FF1	FP4	SV, FP	GP	PSF, PF	FB, LU	FA, FG	VL, VF
		UF	PF, UF UM	PF, F3P SM, 14	11, UF	F1	FP4, PS5	SMG(G-class), FV, LP	CF, PF, DP, PP, VF	01, TSF	FP, SU, SC	FX, GT-SL, GT-SA, GT-SM	VL
	Medium	PM	SM, M3P	MF	MF2, F2	MP4	MV	HQ, GK	PSS, PS	SU, SC	FM, PC, MT	MP	
		UG	PM, XM, XF	SM, M3P	LF, FP (Posi)	M5	FP6, PM5, E47	MP	XQ, XP	PM, TM 23, 24	MU, LB, SF	MT, PMR-	HMP
M	Finish	MF	MF, MMC	PF, SM, M3M, 14	11, UF, GT-LF, FP	F1, F2	FM4	FM, LM	MQ	PSF, PSS, PS	FC, SI LU, SU	FG, SA	VP1
	Medium	MM	MM	M3M, SM	MP, MF	M3	MM4, RM4	MM		PM	MU		VL
K	Medium	UG	KM, KR	SM, 14	MT, T-20, MP, C	M5	F2, FK6, MK4, RK6	MK, None C/B	None C/B	CM, None C/B	MU, None C/B	PC, MT	MP, C25
S	Super Finish	SF	GT-UM		GT-HP, LF	GT-F1	GT-PF2	FS(G-class) LS(G-class)				GT-FGS, SA	VP1
	Finish	SM	MF, UM	SM, PF, F3M, 14	FP, LF	F1, F2	PF4, PS5	FS-P(G-class) LS-P(G-class)	MQ	PSF	SI	FG	VL
	Medium	SR	MM	M3M, SM		MF2	PM5	LS, MS		PSS, PS		PC	MP
N	Finish	AL	AL	AS	HP	AL	MN2	AZ	AP, AH	AL, PP	AG	GT-SA, FL	AK, AR

Technical Information

Comparison Chart - Turning Grades

CVD Coated

ISO	YG-1	ISCAR	SANDVIK	SECO	PRAMET	KENNAMETAL	TUNGALOY	MITSUBISHI	WALTER	TAEGUTEK	KORLOY	SUMITOMO	KYOCERA
P	YG3010	IC8150 IC9150 IC9015	GC4415 GC4305 GC4315	TP0501 TP1500 TP1501	T9310 T9315	KCP05B KCP05 KCPK05 KCP10B KCP10	T9205 T9105 T9215 T9115	UE6105 UE6110 MY5015 MC6015	WPP10G WPP01 WPP05S WPP10S	TT8105B TT8115B TT8105 TT8115	NC3215	AC8015P AC810P AC700G	CA510 CA515 CA5505 CA5515
	YG3115	IC8150 IC9150	GC4315 GC4415	TP1501 TP1500	T9315	KCP10 KCP10B	T9115 T9215	MC9015 MC6115 UE6110	WPP10 WPP10S	TT8115 TT8115B	NC3215	AC8015P AC8020P AC810P	CA515 CA5515
	YG3020	IC8250 IC9250	GC4425 GC4325	TP2500 TP2501	T9325	KCP25 KCP25B	T9225 T9125	MC6025 UE6020	WPP20G WPP20S WMP20S	TT8125B TT8125 LC225P	NC3120 NC3225	AC8025P AC820P	CA025P CA525 CA5525
	YG3030	IC8350 IC9350	GC4235 GC2135 GC4035	TP3500 TP3501	T9335	KCP30B KCP30 KCP40B KCP40	T9235 T9135	MC6035 UE6035 UH6400	WPP30G WPP30S WKP30S		NC3030 NC5330	AC8035P AC830P	CA530 CA5535
M	YG3030	IC6015 IC6025 IC9300 IC520M IC4050 IC635	GC2015 GC2025 GC2035 GC235	TM1501 TM2501 TM3501	T7325 T7330 T7335	KCM15B KCM15 KCM25B KCM25 KCM35B KCM35	T6120 T6020 T6130 T6030	MC7015 MC7025 US7020 US735 UH6400	WMP20S	TT9215 TT9225 TT9235	NC9115 NC9125 NC9135 NC5330	AC6020M AC610M AC6030M AC630M AC6040M AC830P	CA6515 CA6525
	YG2025	IC9025 IC9325	GC2220	TM2501 TM2000		KCM25	T6120 T9125	MC7025 US7020		TT9225 TT5100		AC6020M AC6030M	CA6525
K	YG1010 YG1001	IC5005 IC5010 IC4028 IC8150	GC3205 GC3210 GC3215	TK0501 TK1501	T5305 T5315	KCK05 KCK05B KCK15 KCK15B KCK20 KCK20B KCPK05	T5105 T515 T5115 T1215 T1115 T5125 T5020	MC5005 UC5105 MC5015 UC5115 MY5015	WKK10S WKK20S WAK30 WKP30S WKK10 WKK20	TT3005 TT7005 TT7310 TT7015	NC6310 NC6315 NC5330	AC4010K AC405K AC4015K AC415K AC420K AC8025P	CA310 CA315 CA320 CA4505 CA4515

PVD Coated

P	YG801	IC807 IC830 IC507 IC908	GC1025	TP1030 TP1020	T6310 T8430 T8345	KU10T KCU10 KT315 KU25T KC5010	AH330 AH725 AH730 SH725 SH730	VP10RT MS6015 VP15TF VP20MF VP20RT UP20M	WTA43 WTA41	TT4410 TT9020 TT4430 TT9080 TT8080	PC5300 PC5400 PC3035	AC1030U	PR930 PR1225 PR1535 PR1725
M	YG211	IC3028 IC907	GC1105 GC1115 GC2015	TS2000 TS2050	T6310 T8315	KCU10 KCU5010	AH120 AH140 AH630 AH645	VP10RT	WSM21 WSM01 WSM10S	TT5030	PC8105 PC8110	SC520U AC1030U	
	YG401	IC807						MP9005		TT5080	PC8115	AC5005S	
	YG213	IC908	GC2025	CP200 CP500	T8330 M6330	KCU25 KCU5025	SH725 AH7025	VP15TF VP20MF VP20RT UP20M MP7025	WSM20S	TT9080	PC5300 PC8120 PC9030	AC530U	PR930 PR1225 PR1535 PR1725
	YG214	IC330 IC830	GC2035	CP600	T8430		SH730 GH330 GH730 AH4035		WSM30S	TT8080 TT8020	PC5400		
S	YG401	IC804 IC806 IC830 IC807 IC908	GC1025 GC1105 GC1125	TS2000 TS2050 TS2500 TH1000 CP200	M6330 T6310	KCS10 KCU10 KCU25 KC5010 KC5025	AH110 AH120	MP9005 VP05RT MP9015 VP10RT MP9025 VP20RT	WSM01 WSM10S WSM20S WSM21 WSM30S	TT3010 TT3020 TT5080 TT5030	PC8105 PC8110 PC8115 PC5300 PC5400	AC5015S SC5025S AC510U AC520U	PR005S PR015S PR1535 PR1125 PR1305 PR1310

Non Coated

N	YG10	IC20		KX		K313		HTI10	WK1		H01 H05	H1	KW10
---	------	------	--	----	--	------	--	-------	-----	--	---------	----	------

Cermet

P10	YT100	IC30N	CT5005 CT5015 CT525 GC1525	TP1030 CMP CM	TT010 TT310	KT5020 KT125 KT150	GT730 GT530 NS520 NS720	UP35N	TN60 TN610 TN620 TN90	CT3000	CN1500 CN2500 CC125	T1500A T1000A T2500Z	TN60 TN610 TN620 TC40N
-----	-------	-------	-------------------------------------	---------------------	----------------	--------------------------	----------------------------------	-------	--------------------------------	--------	---------------------------	----------------------------	---------------------------------

Technical Information

Comparison Chart - Milling Grades

ISO	YG-1	SANDVIK	SECO	KENNAMETAL	ISCAR	WALTER	TUNGALOY	MITSUBISHI	TAEGUTEK	KORLOY	SUMITOMO	KYOCERA	HITACHI	DUJET
P	YG712	GC4220 GC1130	T250M MP3000	KC715M KC522M KC635M		WKP25S WKP25 WAM10	T3130 GH330	MP8010 MP6120 MP6130 MP9120	TT7070 TT7080 TT7030	PC3700 PC3600 PC3500	ACP2000 ACZ310	PR730	CY9020 JP4020 TB6045	JC5003
	YG713	GC4230 GC4330	T350M F25M	KC525M	IC950 IC1008	WAM20 WAM30	AH710 AH120 T3225			PC210F	ACP200 ACZ330	PR830 PR630	JP4120 CY250	JC5015
	YG602	GC1030 GC4240	F30M	KC725M KC735M	IC900 IC808 IC908 IC330	WKP35G WKP35S	T3130 AH3035 AH110	VP15TF VP20RT MP9130	TT9030 TT9080	NC5330 PC5300 NCM325 NC5350	ACP3000	PR1025 PR1225	PTH30E JS4060 JP4160	JC5030 JC5040
	YG613	GC4340 GC1040	F40M T60M	KCPM20 KC935M KCPM40	IC830 IC928	WKP45S WKP45X WSP45S	AH725 AH730 GH330 AH130 AH140	FH7020 VP30RT F7030	TT8020 TT8025 TT8080	NC5340 PC5400 NCM335	ACP300 ACZ350	PR1525 PR1230 PR660	JM4160 PTH40H	
M	YG602	GC2030 GC1030	F25M	KC635M KC522M KC725M	IC330	WAM30 WXM35 WSM35	AH725 AH120 GH110 AH730	VP15TF MP7130 MP7030	TT9030 TT9080	PC210F PC5300 NCM325 NC5350	XCU2500 ACM100 ACP200 ACM300	PR1025 PR1225 PR1525 PR630	JX1015 TB6020 CY250 GX2160 JX1045	JC5003 JC5015 JC5030
	YG613	GC2040	F30M F40M	KC722	IC928 IC328	WSP45	AH140 GH340	MP9030 MP7140 VP30RT	TT8080 TT8020	PC9530 NCM335 PC5400	ACP300 ACZ350 ACP400	PR660 PR1535 PR660	TB6045 JX1060 TB6060	JC5040
K	YG5020	GC3220 GC1020	MK1500 MP1500	KC915M	DT7150 IC5100 IC418	WAK15	T1015	VP15TF	TT6290 TT7515 TT6800	NC5330 PC8110	XCK2000	PR1510 PR510		JC5003
	YG501	GC3040	MK2050 MK2000	KCK15 KC520M	IC910 IC810	WKK25S WKP25	T1115 T1215 AH120	MP8010 MC5020	TT6080 TT6030	PC6510 NC5340	ACK200 ACZ310	PR1210 PR905		JC5015
	YG622		MK3000			WKP35	GH110	VP20RT		NC5350 PC5300	ACK300	CA420M		
S	YG602	GC1025 GC1040	F40M MM4500	KC510M KCU30M	IC328 IC408	WSM35S		VP15TF VP30RT	TT9030 TT8020 TT9540	PC5300 PC5400 PC9540	AC520U	CA6535 PR620	ACS05E	
	YG613	S30T S40T	MS2500	KC725M	IC903	WSM45S WSM45X		MP9130	TT8080 TT3540		UPC845		PR660 PR1535	
	YG012	GC1130 GC1030	MP1500 MP3000		IC1008			VP15TF						

ISO ↔ ANSI

ISO	ANSI
CC.. 060201	CC.. 21.50
CC.. 060202	CC.. 21.50.5
CC.. 060204	CC.. 21.51
CC.. 060208	CC.. 21.52
CC.. 09T301	CC.. 32.50
CC.. 09T302	CC.. 32.50.5
CC.. 09T304	CC.. 32.51
CC.. 09T308	CC.. 32.52
CC.. 120402	CC.. 430.5
CC.. 120404	CC.. 431
CC.. 120408	CC.. 432
CC.. 120412	CC.. 433
CN.. 090308	CN.. 322
CN.. 090312	CN.. 323
CN.. 090408	CN.. 332
CN.. 090412	CN.. 333
CN.. 120401	CN.. 430
CN.. 120402	CN.. 430.5
CN.. 120404	CN.. 431
CN.. 120408	CN.. 432
CN.. 120412	CN.. 433
CN.. 120416	CN.. 434
CN.. 160608	CN.. 542
CN.. 160612	CN.. 543
CN.. 160616	CN.. 544
CN.. 190608	CN.. 642
CN.. 190612	CN.. 643
CN.. 190616	CN.. 644
CN.. 190624	CN.. 646
CN.. 250924	CN.. 866
DC.. 070202	DC.. 21.50.5
DC.. 070204	DC.. 21.51
DC.. 070208	DC.. 21.52
DC.. 11T301	DC.. 32.50

ISO	ANSI
DC.. 11T302	DC.. 32.50.5
DC.. 11T304	DC.. 32.51
DC.. 11T308	DC.. 32.52
DC.. 11T312	DC.. 32.53
DN.. 110404	DN.. 331
DN.. 110408	DN.. 332
DN.. 150404	DN.. 431
DN.. 150408	DN.. 432
DN.. 150412	DN.. 433
DN.. 150604	DN.. 441
DN.. 150608	DN.. 442
DN.. 150612	DN.. 443
SC.. 09T304	SC.. 32.51
SC.. 09T308	SC.. 32.52
SC.. 120408	SC.. 432
SD.. 1203	SD.. 42
SC.. 120412	SC.. 433
SD.. 120420	SD.. 435
SD.. 1504	SD.. 53
SE.. 1203	SE.. 42
SN.. 090304	SN.. 321
SN.. 090308	SN.. 322
SN.. 120404	SN.. 431
SN.. 120408	SN.. 432
SN.. 120412	SN.. 433
SN.. 120416	SN.. 434
SN.. 150612	SN.. 543
SN.. 190612	SN.. 643
SN.. 190616	SN.. 644
SN.. 190624	SN.. 646
SN.. 250724	SN.. 856
SN.. 250924	SN.. 866
SP.. 1203	SP.. 42
SP.. 120308	SP.. 422

ISO ↔ ANSI

ISO	ANSI
SP.. 1504	SP.. 53
TC.. 110204	TC.. 21.51
TC.. 110208	TC.. 21.52
TC.. 16T302	TC.. 32.50.5
TC.. 16T304	TC.. 32.51
TC.. 16T308	TC.. 32.52
TN.. 160404	TN.. 331
TN.. 160408	TN.. 332
TN.. 160412	TN.. 333
TN.. 220404	TN.. 431
TN.. 220408	TN.. 432
TN.. 220412	TN.. 433
TN.. 220416	TN.. 434
TP.. 1603	TP.. 32
TP.. 160308	TP.. 322
TP.. 2204	TP.. 43
VB.. 110301	VB.. 220
VB.. 110302	VB.. 220.5
VB.. 110304	VB.. 221
VB.. 110308	VB.. 222
VB.. 160402	VB.. 330.5
VB.. 160404	VB.. 331
VB.. 160408	VB.. 332
VC.. 110301	VC.. 220
VC.. 110302	VC.. 220.5
VC.. 110304	VC.. 221
VC.. 110308	VC.. 222
VC.. 160402	VC.. 330.5
VC.. 160404	VC.. 331
VC.. 160408	VC.. 332
VN.. 160404	VN.. 331
VN.. 160408	VN.. 332
VN.. 160412	VN.. 333
WN.. 060404	WN.. 331

ISO	ANSI
WN.. 060408	WN.. 332
WN.. 060412	WN.. 333
WN.. 080404	WN.. 431
WN.. 080408	WN.. 432
WN.. 080412	WN.. 433
WN.. 080416	WN.. 434

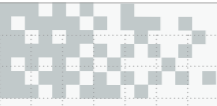

HIGH QUALITY PRODUCTS and ON TIME DELIVERY for WORLD-WIDE CUSTOMERS

Since 1982, YG-1 has been committed to quality, innovation and the unique customer experience. Our performance and experience have granted YG-1 the global impression of one of the leading manufacturers of high quality cutting tool solutions. This global footprint expands over 75 countries, with international logistic centers, pledging to our customers to give the best service available today - and tomorrow.

EUROPE



ASIA PACIFIC



AMERICAS



AFRICA



YG-1 CO., LTD.

* For the more information on sales network, please contact the head office as below;

HEAD OFFICE

13-40, Songdogwahak-ro 16beon-gil, Yeonsu-gu, Incheon 21984, South Korea

Phone: +82-32-526-0909 www.yg1.solutions E-mail: yg1@yg1.solutions



HEAD OFFICE

13-40, Songdogwahak-ro 16beon-gil, Yeonsu-gu, Incheon 21984, South Korea

Phone: +82-32-526-0909

<https://www.yg1.solutions> E-mail: yg1@yg1.solutions

Note The information is provided for reference only. Tool specifications are subject to change without prior notice. Although we endeavor to supply accurate and timely information, there can be no guarantee to cover every particular application. YG-1 or publishers are not liable for any damage for use of the information.



Search 'YG-1' on social media outlets

YG1YET2404005